

BENCHMARKTM_{MC}

8" BENCH GRINDER 1325-501



5 Year Limited Warranty



**READ ALL INSTRUCTIONS BEFORE FIRST USE.
KEEP THIS MANUAL FOR FUTURE REFERENCE.
KEEP AWAY FROM CHILDREN.**



**WEAR CSA APPROVED
EYE PROTECTION**



**WEAR EAR
PROTECTION**



**WEAR A FACE
MASK**

PRODUCT SPECIFICATIONS

8" BENCH GRINDER	
Rating	120V~ 60 Hz, 4.8 Amp Induction motor
Max Wheel Diameter	8" (203mm)
Max Wheel Face	1" (25mm)
No Load Speed	3,450 RPM
Arbor Size	5/8" (16mm)
Cord	10 foot SJ Rubberized
Replacement Wheel	1362-602 & 1362-603
Weight	31.7 Lb (14.4kg)

NEED ASSISTANCE?

Call us on our toll- free customer support line:
1-866-349-8665 (Monday through Friday 9am – 5pm
Eastern Standard Time)

- Technical questions
- Replacement parts
- Parts missing from package

TABLE OF CONTENTS



Product Specifications.....1
Table of Contents.....2
General Safety Warnings.....3
Specific Safety Rules.....5
Symbols.....7
Extension Cord Safety.....8
Know Your Bench Grinder.....9
Assembly and Operation.....9-11
Maintenance.....12
Explosion Drawing.....13
Parts List.....14
Warranty.....16

GENERAL SAFETY WARNINGS



WARNING:

Before using this tool or any of its accessories, read this manual and follow all Safety Rules and Operating Instructions. The important precautions, safeguards and instructions appearing in this manual are not meant to cover all possible situations. It must be understood that common sense and caution are factors which cannot be built into the product.

SYMBOL	MEANING
	<p>ALWAYS WEAR EYE PROTECTION THAT CONFORMS WITH CSA Z94.3 or ANSI SAFETY STANDARD Z87.1</p> <p>FLYING DEBRIS can cause permanent eye damage. Prescription eyeglasses ARE NOT a replacement for proper eye protection.</p> <p>Non-compliant eyewear can cause serious injury if broken during the operation of a power tool.</p>
	<p>Use hearing protection, particularly during extended periods of operation of the tool, or if the operation is noisy.</p>
	<p>WEAR A DUST MASK THAT IS DESIGNED TO BE USED WHEN OPERATING A POWER TOOL IN A DUSTY ENVIRONMENT.</p> <p>Dust that is created by power sanding, sawing, grinding, drilling, and other construction activities may contain chemicals that are known to cause cancer, birth defects, or other genetic abnormalities.</p> <p>These chemicals include:</p> <ul style="list-style-type: none"> • Lead from lead-based paints • Crystalline silica from bricks, cement, and other masonry products • Arsenic and chromium from chemically treated lumber <p>the level of risk from exposure to these chemicals varies, according to how often this type of work is performed. In order to reduce exposure to these chemicals, work in a well-ventilated area, and use approved safety equipment, such as a dust mask that is specifically designed to filter out microscopic particles.</p>

READ ALL INSTRUCTIONS



WARNING! Read and understand all instructions before using this tool. The operator must follow basic precautions to reduce the risk of personal injury and/or damage to the equipment.

- 1. KEEP GUARDS IN PLACE and in working order.**
- 2. REMOVE ADJUSTING KEYS AND WRENCHES.** Form habit of checking to see that keys and adjusting wrenches are removed from tool before turning it on.
- 3. KEEP WORK AREA CLEAN.** Cluttered areas and benches invite accidents.
- 4. DON'T USE IN DANGEROUS ENVIRONMENT.** Don't use power tools in damp or wet locations, or expose them to rain. Keep work area well lighted.
- 5. KEEP CHILDREN AWAY.** All visitors should be kept safe distance from work area.
- 6. MAKE WORKSHOP KID PROOF** with padlocks, master switches, or by removing starter keys.
- 7. DON'T FORCE TOOL.** It will do the job better and safer at the rate for which it was designed.
- 8. USE RIGHT TOOL.** Don't force tool or attachment to do a job for which it was not designed
- 10. WEAR PROPER APPAREL.** Do not wear loose clothing, gloves, neckties, rings, bracelets, or other jewelry which may get caught in moving parts. Nonslip footwear is recommended. Wear protective hair covering to contain long hair.
- 11. ALWAYS USE SAFETY GLASSES.** Also use face or dust mask if cutting operation is dusty. Everyday eyeglasses only have impact resistant lenses, they are NOT safety glasses.
- 12. SECURE WORK.** Use clamps or a vise to hold work when practical. It's safer than using your hand and it frees both hands to operate tool.
- 13. DON'T OVERREACH.** Keep proper footing and balance at all times.
- 14. MAINTAIN TOOLS WITH CARE.** Keep tools sharp and clean for best and safest performance. Follow instructions for lubricating and changing accessories.
- 15. DISCONNECT TOOLS** before servicing; when changing accessories, such as blades, bits, cutters, and the like.
- 16. REDUCE THE RISK OF UNINTENTIONAL STARTING.** Make sure switch is in off position before plugging in.
- 17. USE RECOMMENDED ACCESSORIES.** Consult the owner's manual for recommended accessories. The use of improper accessories may cause risk of injury to persons.
- 18. NEVER STAND ON TOOL.** Serious injury could occur if the tool is tipped or if the cutting tool is unintentionally contacted.
- 19. CHECK DAMAGED PARTS.** Before further use of the tool, a guard or other part that is damaged should be carefully checked to determine that it will operate properly and perform its intended function – check for alignment of moving parts, binding of moving parts, breakage of parts, mounting, and any other conditions that may affect its operation. A guard or other part that is damaged should be properly repaired or replaced.
- 20. DIRECTION OF FEED.** Feed work into a blade or cutter against the direction of rotation of the blade or cutter only.
- 21. NEVER LEAVE TOOL RUNNING UNATTENDED. TURN POWER OFF.** Don't leave tool until it comes to a complete stop

SERVICE

Have your power tool serviced by a qualified repair person using only identical replacement parts. This will ensure that the safety of the power tool is maintained. Use only identical replacement

SPECIFIC SAFETY RULES



WARNING! DO NOT let comfort or familiarity with product (gained from repeated use) replace strict adherence to the tool safety rules. If you use this tool unsafely or incorrectly, you can suffer serious personal injury.

DANGER! When the tool is in operation, keep hands away from the saw blade and the area it is being applied to. Failure to follow this warning will result in amputation, serious personal injury or death.

- Do not operate with any guard disabled, damaged, or removed. Moving guards must move freely and close instantly.
- Never operate the grinder with broken wheels. The grinding wheels operate at 3 450 RPM. A broken wheel could turn into a missile.
- Never leave the tool running while unattended.
- Avoid unintentional starting. Prepare to begin work before turning on the tool.
- Never stick an object against a wheel to stop the grinder. Let it slow on its own.
- Always use the tool rest and safety guard. Supports and guards are essential for safe grinder operation.
- Use only properly sized wheels. The wrong sized wheel can dangerously increase or decrease operating speed at the grinding surface. A wheel that is too large could come in contact with the wheel housing, potentially damaging the machine.
- Do not overtighten wheel nut.
- Always wear eye protection. The grinder can throw off sparks and tiny metal shards. Use eye protection to avoid operator injury.
- Adjust tool rest properly. The grinder has the potential for binding against a workpiece introduced at an improper angle - and send it flying. Avoid grinding your workpiece at angles greater than 90° to the direction of wheel travel.
- Allow grinder to reach full speed. Let the grinding wheel reach its full operating speed before using the grinder.
- Secure grinder. Attach the grinder firmly to your benchtop. Secure attachment will ensure your grinder will not move when operated.
- Avoid overheating workpiece. Excessive or prolonged grinding on a workpiece can heat it to the point where it becomes dangerous to the operator. Excessive grinding can also soften your workpiece and ruin its edge.
- Never grind small stock. Do not attempt to grind or sharpen anything that cannot be adequately supported by the tool rest. Use clamping pliers or a similar holder when grinding parts which cannot be held easily by hand.
- Keep a clean work area. The chances of an accident are far less if the area around your grinder is kept free of clutter.
- Avoid loose fitting clothing and tie back long hair. A grinder's spindle, spinning at 3,450 RPM, can suck a tremendous amount of material in a very short time - given the chance. Don't give it the chance.
- Accessories must be rated for at least the speed recommended on the tool warning label. Wheels and other accessories running over the rated speed can fly apart and cause injury.
- Never start the tool with a person in line with the wheel. This includes the operator
- Do not operate the grinder near flammable liquids, gases or dust. Sparks or hot chips from grinding may ignite combustible materials.
- Maintain labels and nameplates on the tool. These carry important safety information. If unreadable or missing, contact Harbor Freight Tools for a replacement.

WARNING! Some dust created by power sanding, sawing, grinding, drilling, and other construction activities, contains chemicals known to the State of California to cause cancer, birth defects or other reproductive harm. Some examples of these chemicals are: Lead from lead-based paints, Crystalline silica from bricks and cement or other masonry products, Arsenic and chromium from chemically treated lumber. Your risk from these exposures varies, depending on how often you do this type of work. To reduce your exposure to these chemicals: work in a well ventilated area, and work with approved safety equipment, such as those dust masks that are specially designed to filter out microscopic particles.

WARNING! Handling the cord on this product will expose you to lead, a chemical known to the State of California to cause cancer, and birth defects or other reproductive harm. Wash hands after handling.

Vibration Safety

This tool vibrates during use. Repeated or long-term exposure to vibration may cause temporary or permanent physical injury, particularly to the hands, arms and shoulders. To reduce the risk of vibration-related injury:

1. Anyone using vibrating tools regularly or for an extended period should first be examined by a doctor and then have regular medical check-ups to ensure medical problems are not being caused or worsened from use. Pregnant women or people who have impaired blood circulation to the hand, past hand injuries, nervous system disorders, diabetes, or Raynaud's Disease should not use this tool. If you feel any medical or physical symptoms related to vibration (such as tingling, numbness, and white or blue fingers), seek medical advice as soon as possible.
2. Do not smoke during use. Nicotine reduces the blood supply to the hands and fingers, increasing the risk of vibration-related injury.
3. Use tools with the lowest vibration when there is a choice between different processes.
4. Include vibration-free periods each day of work.
5. Grip workpiece as lightly as possible (while still keeping safe control of it). Let the tool do the work.
6. To reduce vibration, maintain the tool as explained in this manual. If any abnormal vibration occurs, stop use immediately

Double insulation

Double insulation is a concept in safety 1n electric power tools, which eliminates the need for the usual three-wire grounded power cord. All exposed metal parts are isolated from the internal metal motor components with protecting insulation. Double insulated tools do not need to be grounded. The double insulated system is intended to protect the user from shock Resulting from a break in the tool'S internal wiring . Observe all normal safety precautions to avoid electrical shock. The double insulated system is intended to protect the user from shock resulting from a break in the tool's internal wiring. Observe all normal safety precautions to avoid electrical shock.

NOTE: Servicing of a tool with double insulation requires extreme care and knowledge of the system and should be Performed only by a qualified service technician. For service, we suggest you return the tool to the nearest authorized Service center for repair. Always use original factory replacement parts when servicing.

Electrical Connection

This tool has a precision-built electric motor. It should be connected to a power supply that is 120 volts, 60 Hz, AC only (normal household current). Do not operate this tool on direct current (DC). A substantial voltage drop will cause a loss of power and the motor will overheat. If your tool does not operate when plugged into an outlet, double-check the power supply.

Grounding Instruction

In the event of a malfunction or breakdown, grounding provides a path of least resistance for electric current to reduce the risk of electric shock. This tool is equipped with an electric cord having an equipment-grounding conductor and a grounding plug. The plug must be plugged into a matching outlet that is properly installed and grounded in accordance with all local codes and ordinances.

Do not modify the plug provided. If it will not fit the outlet, have the proper outlet installed by a qualified electrician. Improper connection of the equipment-grounding conductor can result. It in electrical shock. The conductor with insulation having an outer surface that is green with or without yellow stripes is the equipment grounding conductor. If repair or replacement of the electric cord or plug is necessary, do not connect the equipment-grounding conductor to a live terminal. Check with a qualified electrician or service personnel if the grounding instructions are not completely understood, or if in doubt as to whether the tool is properly grounded. Repair or replace a damaged or worn cord immediately. This tool is intended for use on a circuit that has an outlet like the one shown in Fig.1. It also has a grounding pin like the one shown.

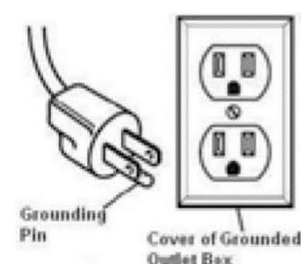

Fig. 1



WARNING:
ALL ELECTRICAL CONNECTIONS MUST BE DONE BY A QUALIFIED ELECTRICIAN. FAILURE TO COMPLY MAY RESULT IN SERIOUS INJURY! ALL ADJUSTMENTS OR REPAIRS MUST BE DONE WITH THE MACHINE DISCONNECTED FROM THE POWER SOURCE. FAILURE TO COMPLY MAY RESULT IN SERIOUS INJURY!

SAFETY SYMBOLS



WARNING: Some of the following symbols may appear on your tool. Study these symbols and learn their meaning. Proper interpretation of these symbols will allow for more efficient and safer operation of this tool.

V	Volts	3~	Three-phase alternating current with neutral
A	Amperes		
Hz	Hertz	— — —	Direct current
W	Watts	n _o	No load speed
kW	Kilowatts	~	Alternating or direct current
μF	Microfarads	□	Class II construction
L	Litres	⚠	Splash-proof construction
kg	Kilograms	💧	Watertight construction
H	Hours	⊕	Protective grounding at terminal, Class I tools
N/cm ²	Newtons per square centimeter	.../min	Revolutions or reciprocations per minute
Pa	Pascals	∅	Diameter
Min	Minutes	0	Off position
S	Seconds	➔	Directional arrow
~ or AC	Alternating current	⚠	Warning symbol
3~	Three-phase alternating current	👁	Wear your safety glasses



This symbol designates that this tool is listed with Canadian and U.S. requirements by UL

UL 987 , Stationary and Fixed Electric Tools

CSA C22 . 2 No . 71.2-10 Electric Bench Tools

EXTENSION CORD SAFETY

WARNING

Keep the extension cord clear of the working area.

Position the cord so it will not get caught on the workpiece, tools or any other obstructions while you are working with the power tool.

1. Make sure any extension cord used with this tool is in good condition. When using an extension cord, be sure to use one of heavy enough gauge to carry the current the tool will draw. An undersized cord will cause a drop in line voltage resulting in loss of power and overheating.
2. The table below shows the correct size to use according to cord length and nameplate ampere rating. If in doubt, use the next heavier gauge. The smaller the gauge number the heavier the cord.
3. Be sure your extension cord is properly wired and in good condition. Always replace a damaged extension cord or have it repaired by a qualified electrician before using it. Protect your extension cord from sharp objects, excessive heat and damp or wet areas.
4. Use a separate electrical circuit for your power tools. This circuit must not be less than 14 gauge wire and should be protected with either a 15 A time delayed fuse or circuit breaker. Before connecting the power tool to the power source, make sure the switch is in the OFF position and the power source is the same as indicated on the nameplate. Running at lower voltage will damage the motor.

MINIMUM GAUGE(AWG)EXTENSION CORDS(120V)USE ONLY					
Amperage rating		Total length			
More than	Not more than	25' (7.5 m)	50' (15 m)	100' (30 m)	150' (45 m)
	6	18	16	16	14
6	10	18	16	14	12
10	12	16	16	14	12
12	16	14	12	Not Applicable	

KNOW YOUR BENCH GRINDER

1. Interlocking knob for Eye Shield
2. Magnifier Eye Shield
3. Spark Deflector
4. Grinding Wheel
5. Tool rest bracket
6. Interlocking knob for tool rest bracket
7. Interlocking knob for Eye Shield Rod
8. Eye Shield
9. Worklight
10. Wheel Cover
11. Interlocking knob for tool rest
12. Power Switch

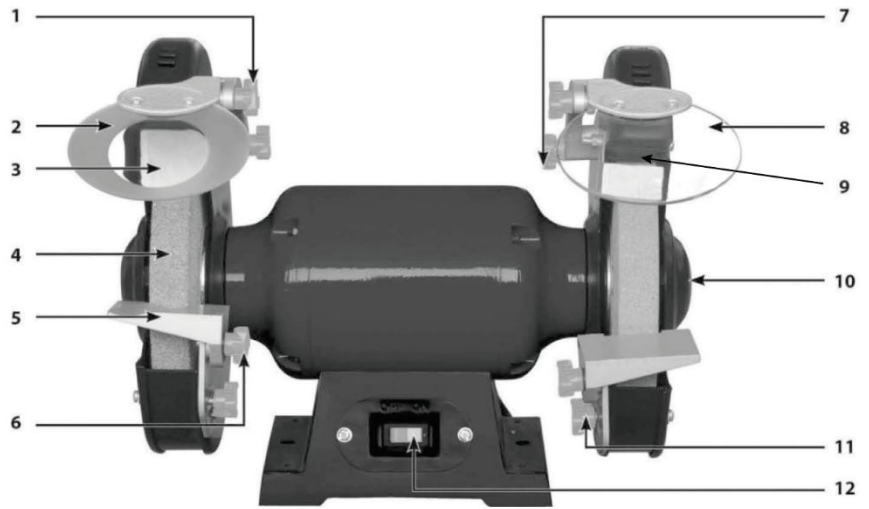

ASSEMBLY AND OPERATION

WARNING: Read the entire important safety information section at the beginning of this manual including All text Under subheadings therein before assembling or use of this power tool.

WARNING: To prevent serious injury from accidental operation, disconnect the power plug before carrying out any adjustments or maintenance.

WARNING: Always make sure your bench grinder is securely mounted to a workbench or an approved workstand. Failure to do so could result in an accident resulting in possible serious personal injury.

Mounting Eye Shield Rod and Eye Shield

- Mount the magnifier eye shield (Part #2 on the “Know your Bench Grinder page) and the eye shield (Part # 8 on the “Know your Bench Grinder page) to the shield rod by using the Interlocking knob (Part # 1 on the “Know your Bench Grinder page). (Fig. 3)
- Mount the shield rod to the inside of the wheel guards by using the Interlocking knob (Part # 7 on the “Know your Bench Grinder page). (Fig. 4)
- Use the illustration (Fig. 3) as a guide to determine which shield rod is mounted on the left and which shield rod is mounted on the right of the grinder.
- Once shield rods are firmly in place, slide the shield bracket (Parts #1 & #7 on the “Know your Bench Grinder page above) onto the shield rod. Tighten the carriage bolt leaving it loose enough to allow the safety shield to be raised and lowered easily.

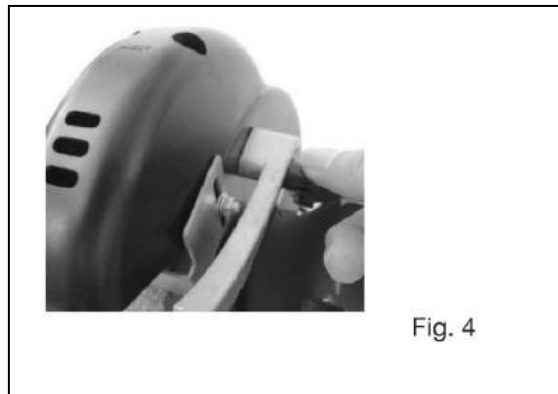
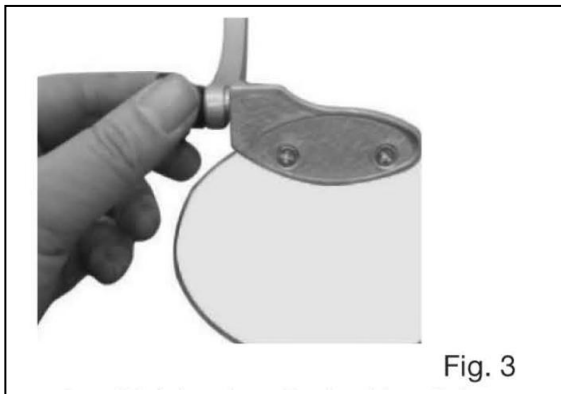

Mounting and Adjusting Tool Rest (Refer to parts noted on the "Know your Bench Grinder page above)

- Mount the tool rests (5) to the tool rest bracket by using the Interlocking knob (6). (Fig. 5)
- Mount the tool rest bracket by using the Interlocking knob (11)

Attention: The pin(1) should be inserted in the down slot of the tool rest bracket.

- Before tightening the Interlocking knob (6) for tool rest bracket, adjust the gap between the grinding wheel and the tool rest to a maximum of 1/16 inch. And then tighten securely.

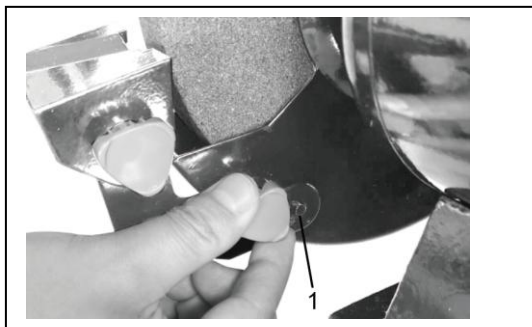
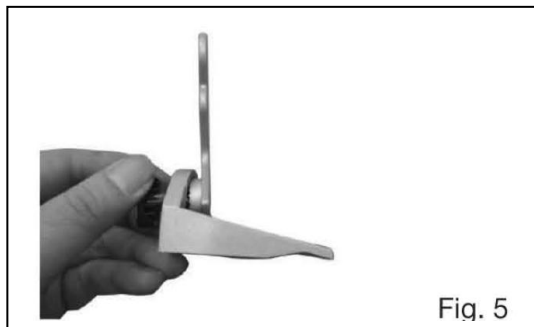

WARNING: The tool rest should only be adjusted when the grinding wheel is completely stationary, and the tool is disconnected from the power supply.

Adjusting Spark Deflector (Refer to parts noted on the "Know your Bench Grinder page above)

- Adjust the spark deflectors (3) to within 1/16 inch of the grinding wheel by turning the screws and hex bolts.
- After adjusting, tighten the hex bolts securely.

WARNING: Before connecting your power tool to power supply, always check to be sure switch is not in the ON position. Failure to do so could result in accidental starting of your power tool.

Switching ON/OFF (Refer to parts noted on the "Know your Bench Grinder page above)

1. Check that the switch is in the "OFF" position before connecting the tool to the power supply.
2. Press the power switch into the "ON" position to start the bench grinder. (Fig. 7)
3. Always keep the power cord out of the way of the tool's moving parts.
4. To switch off the grinder, press the power switch into the "OFF" position.

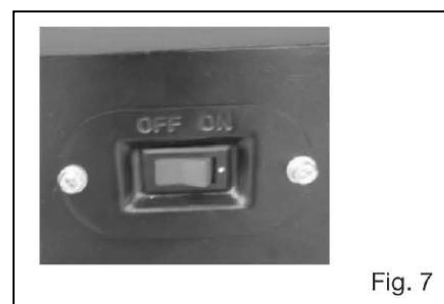

Auto-On Work Light

The Bench Grinder comes equipped with a permanently mounted worklight that automatically lights the work area once the tool ON/OFF switch is activated for safer, more accurate grinding and sharpening.

Grinding

WARNING: Always wear safety goggles or safety glasses with side shields during power tool operation or when blowing dust. If operation is dusty, wear a dust mask.

1. Make sure that the Switch is in the OFF-position, then plug in the tool.
2. Turn on the tool.
3. Allow the tool to come up to full speed before touching the wheel.
4. Apply the workpiece to the wheel, allowing the tool to operate at full speed. If the tool bogs down, use lighter pressure.
5. To create a smoother surface, keep the workpiece moving over the wheel.
6. To prevent accidents, turn off the tool and unplug the tool from its electrical outlet after use. Clean, then store the tool indoors out of children's reach.

Replacing the Grinding Wheel

Replacing a Grinding Wheel

- The Grinding Wheel MUST be:
- Rated to at least 3,450 RPM.
- No larger than 8" (152.4 mm) in diameter
- Fitted with a 5/8" round arbor hole.
- 1" thick.
- Suitable for edge grinding, not surface grinding
- Dry and clean.
- Inspected for damage.

Steps (Refer to parts noted on the "Know your Bench Grinder page above)

1. Remove the eye shield rod, the tool rests (5) and eye shield (2 & 8).
2. Loosen the three screws and remove the wheel cover (10). (Fig. 8)
3. Turn the nut clockwise with a wrench (not included). Remove the nut and the outer flange from the motor spindle. (Fig. 9)
4. Remove the grinding wheel and fit the new one over the motor spindle
5. Replace the grinding wheel (4) and put the outside flange and the nut back. Tighten the nut by hand.
6. Turn the nut counterclockwise to tighten.
7. Mount the wheel cover (10) and eye shield (8) in reverse order.

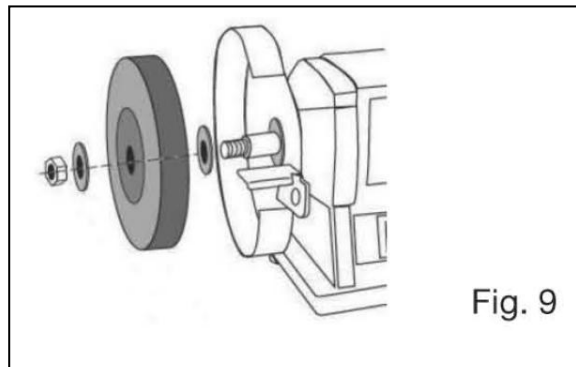
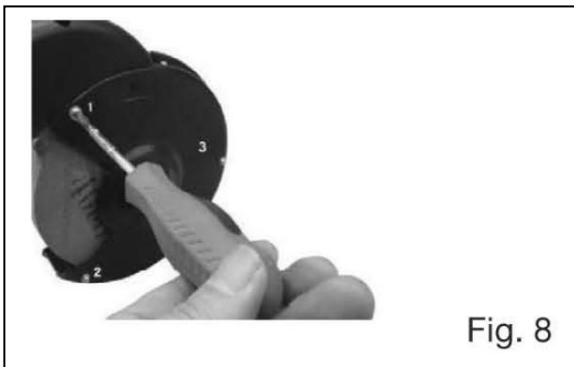

WARNING: Always disconnect the bench grinder from the power supply before performing any assembly or adjustment

Failure to do so could result in accidental started resulting in possible serious personal injury

MAINTENANCE

WARNING: To prevent serious injury from accidental operation Turn the Power switch of the tool to its "OFF" position and

unplug the tool from its electrical outlet before performing any inspection, maintenance, or cleaning procedures.

Cleaning

Clean out dust and debris from vents and electrical contacts by blowing with compressed air. Keep tool handles clean, dry

and free of oil or grease.

Certain cleaning agents and solvents are harmful to plastics and other insulated parts. Some of these include gasoline,

turpentine, lacquer thinner, paint thinner, chlorinated cleaning solvents , ammonia and household detergents containing

ammonia. Never use flammable or combustible solvents around tools.

WARNING: Tool service must be performed only by qualified repair personnel. Service or maintenance performed by

unqualified personnel could result in a risk of injury. If the tool does not work properly, return the tool to a service facility

for repairs.

Lubrication

All of the bearings in this tool are lubricated with a sufficient amount of high grade lubricant for the life of the unit under

normal operating conditions . Therefore, no further lubrication is required.

TROUBLESHOOTING		
Problem	Possible	Likely Solutions
Machine switched on but will not run	There is a break in the power supply to the machine The switch may be damaged	Check power at outlet Check that cord is plugged in
The electric motor becomes hot	The motor has become overloaded The motor is defective	Give the motor a chance to cool down Contact Customer Service @ 1-866-349-8665
Follow all safety precautions whenever diagnosing or servicing the tool. Disconnect power supply before service.		

EXPLODED VIEW

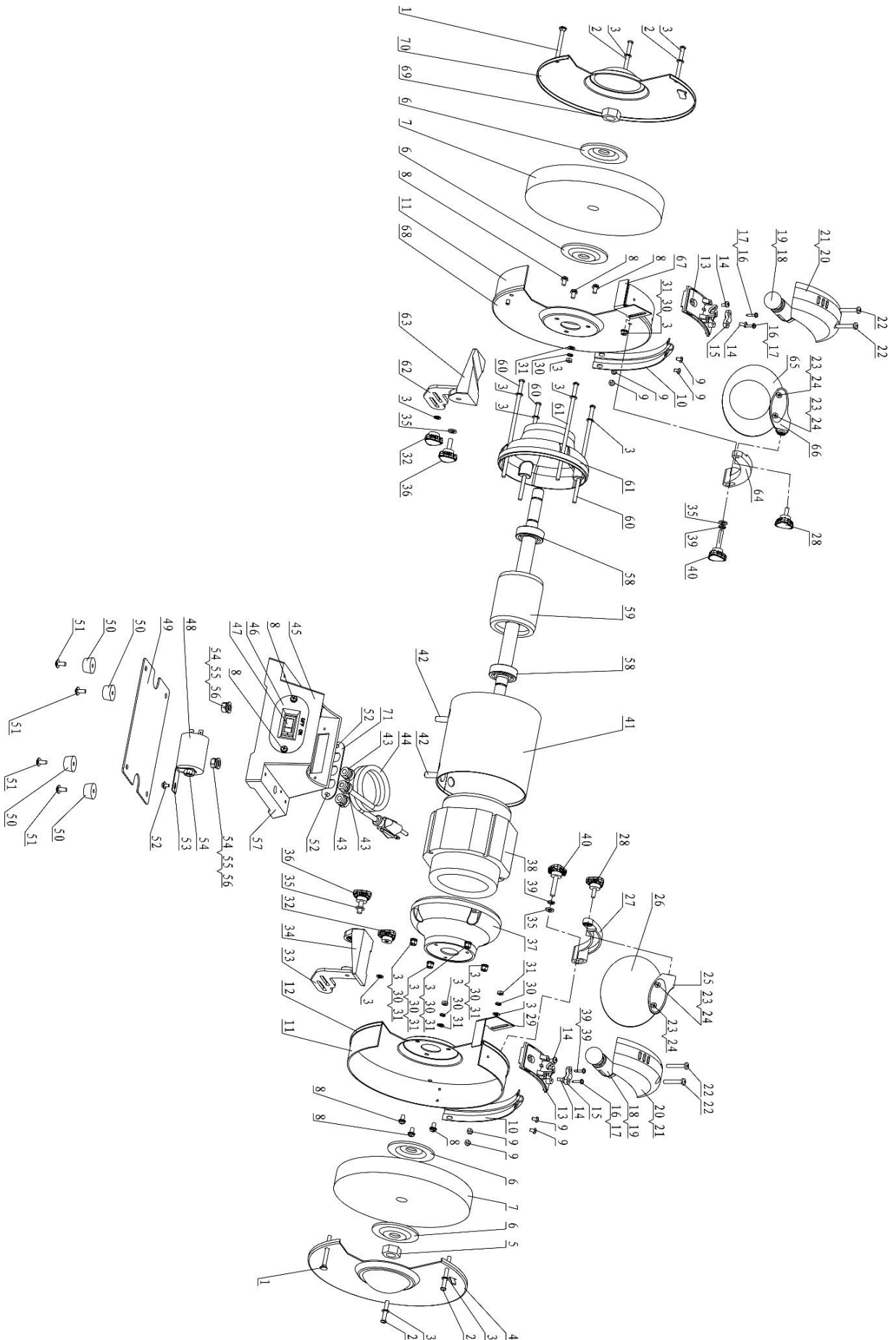

PARTS LIST

WARNING! When servicing, use only original equipment replacement parts. The use of any other parts may create a safety hazard or cause damage to the tool. Any attempt to repair or replace electrical parts on this saw may create a safety hazard unless repairs are performed by a qualified technician. For more information, call the Toll-free Helpline, at 1-866-349-8665.

Key#	Part #	Part Name	Qty
1	1325-501-001	Square neck screws M5 x 50	2
2	1325-501-002	Screw M5 x 50	6
3	1325-501-003	Washers 5	18
4	1325-501-004	Right guard cover	1
5	1325-501-005	Nut M16 (right)	1
6	1325-501-006	Chuck	4
7	1325-501-007	Grinding wheel	2
8	1325-501-008	Screws M5 x 10	8
9	1325-501-009	Screw M4 x 6	8
10	1325-501-010	Walking trough	2
11	1325-501-011	Hoarding	2
12	1325-501-012	Right guard bottom	1
13	1325-501-013	Lampholder	2
14	1325-501-014	Screw M4 x 8	4
15	1325-501-015	Plastic bridge	2
16	1325-501-016	S2.9 x 16 self-tapping screws	4
17	1325-501-017	Washer 3	4
18	1325-501-018	Lamp holder	2
19	1325-501-019	Light bulb	2
20	1325-501-020	Lampshade	2
21	1325-501-021	Translucent sheet	2
22	1325-501-022	Screw M5 x 30	4
23	1325-501-023	Countersunk head screws M4 x 10	4
24	1325-501-024	Nut M4	4
25	1325-501-025	Right guard mirror plate	1
26	1325-501-026	Right goggles	1
27	1325-501-027	guard mirror bracket	1
28	1325-501-028	Handle screw M5 x 14	2
29	1325-501-029	Right block gray board	1
30	1325-501-030	Shells pad 5	10
31	1325-501-031	Nut M5	4
32	1325-501-032	Handle nut M5	2
33	1325-501-033	Right side table	1
34	1325-501-034	Right countertops	1
35	1325-501-035	Washers 6	2
36	1325-501-036	Handle screw M6 x 18	2
37	1325-501-037	Right cover	1
38	1325-501-038	Stator	1
39	1325-501-039	Shells pad 6	2
40	1325-501-040	Handle screw M6 x 30	2

Key#	Part #	Part Name	Qty
41	1325-501-041	Motor cylinder	1
42	1325-501-042	Square neck screw M8 x 25	2
43	1325-501-043	Pull-off	3
44	1325-501-044	Power line	1
45	1325-501-045	Base	1
46	1325-501-046	Switch panel	1
47	1325-501-047	Switch	1
48	1325-501-048	Capacitance	1
49	1325-501-049	Floor	1
50	1325-501-050	Rubber feet	4
51	1325-501-051	Screws M5 x 12	4
52	1325-501-052	Screws M4 x 8	3
53	1325-501-053	Fixed capacitor plate	1
54	1325-501-054	Nut M8	3
55	1325-501-055	Shells pad 8	2
56	1325-501-056	Washers 8	2
57	1325-501-057	Base	1
58	1325-501-058	Bearing	2
59	1325-501-059	Rotor	1
60	1325-501-060	Screw MS x 150	4
61	1325-501-061	Left end cap	1
62	1325-501-062	Left side table	1
63	1325-501-063	Left countertops	1
64	1325-501-064	Left bracket goggles	1
65	1325-501-065	Left goggles	1
66	1325-501-066	Left goggles plate	1
67	1325-501-067	Left blank gray board	1
68	1325-501-068	Bottom left guard	1
69	1325-501-069	Nuts M16 (left)	1
70	1325-501-070	Left guard cover	1
71	1325-501-071	Pressure line board	1

WARRANTY

BENCHMARK 8" BENCH GRINDER

If this Benchmark tool fails due to a defect in material or workmanship within five years from the date of purchase, return it to any Home Hardware store with the original bill of sale for exchange. 3-year warranty for the battery and charger. This warranty does not include expendable parts including but not limited to blades, brushes, belts, light bulbs. This warranty covers defects in material or workmanship only. It does not cover normal wear and tear, failure due to abuse/misuse, or defects caused by careless or accidental mishandling. If this Benchmark product is used for commercial or rental purposes, this warranty does not apply.

8" BENCH GRINDER



BENCHMARK™

BENCHMARK TOOLS CANADA

ST. JACOBS, ONTARIO N0B 2N0

© 2022 Home Hardware Stores Limited

CUSTOMER SERVICE/TECH SUPPORT

1-866-349-8665

1325-501

Made in China



* This Benchmark™ product carries a five (5) year LIMITED warranty against defects in workmanship and materials. The charger and batteries carry a three (3) year LIMITED warranty.



READ ALL INSTRUCTIONS BEFORE FIRST USE. KEEP THIS MANUAL FOR FUTURE REFERENCE. KEEP AWAY FROM CHILDREN.



**WEAR CSA APPROVED
EYE PROTECTION**



**WEAR EAR
PROTECTION**



**WEAR A
FACE
MASK**