

MASTER FORCE[®]

6 1/2" PLUNGE CUT CIRCULAR SAW

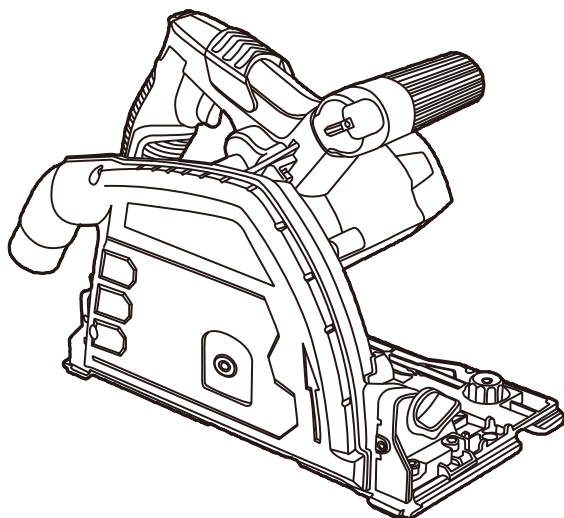

241-0706

For questions/comments, technical assistance or repair parts –
Please call toll free: 1-866-349-8665 (M–F 9am–5pm EST)
Email us at: customerservice@powertoolsplus.ca

OPERATOR'S MANUAL

⚠ CAUTION: To Reduce The Risk Of Injury, User Must Read And Understand Operator's Manual. Save These Instructions For Future Reference.

TABLE OF CONTENTS

Front cover	1
Table of contents	2
General safety warnings.....	3-4
Eye, ear & lung protection.....	3-4
Electrical safety.....	4
Power tool safety.....	5-6
Specific Safety Rules.....	7-9
Extension cord safety	9
Product specifications	10
Symbols.....	11
Know your Plunge cut circular saw.....	12
Assembly and Operating.....	13-17
Maintenance	18-19
Replacing carbon motor brushes	18-19
Exploded view	20
Parts list	21-22
Warranty	23
Back cover	24

GENERAL SAFETY WARNINGS

⚠ WARNING: Before using this tool or any of its accessories, read this manual and follow all Safety Rules and Operating Instructions. The important precautions, safeguards and instructions appearing in this manual are not meant to cover all possible situations. It must be understood that common sense and caution are factors which cannot be built into the product.

This instruction manual includes the following:

- General Safety Rules
- Specific Safety Rules and Symbols
- Functional Description
- Assembly
- Operation
- Maintenance
- Accessories

EYE, EAR & LUNG PROTECTION



ALWAYS WEAR EYE PROTECTION THAT CONFORMS WITH CSA REQUIREMENTS or ANSI SAFETY STANDARD Z87.1

FLYING DEBRIS can cause permanent eye damage. Prescription eyeglasses ARE NOT a replacement for proper eye protection.



WARNING: Non-compliant eyewear can cause serious injury if broken during the operation of a power tool.



WARNING: Use hearing protection, particularly during extended periods of operation of the tool, or if the operation is noisy.

SAVE THESE INSTRUCTIONS FOR REFERENCE

POWER TOOL SAFETY

EYE, EAR & LUNG PROTECTION – cont'd



WEAR A DUST MASK THAT IS DESIGNED TO BE USED WHEN OPERATING A POWER TOOL IN A DUSTY ENVIRONMENT.



WARNING: Dust that is created by power sanding, sawing, grinding, drilling, and other construction activities may contain chemicals that are known to cause cancer, birth defects, or other genetic abnormalities. These chemicals include:

Lead from lead-based paints

Crystalline silica from bricks, cement, and other masonry products

Arsenic and chromium from chemically treated lumber

The level of risk from exposure to these chemicals varies, according to how often this type of work is performed. In order to reduce exposure to these chemicals, work in a well-ventilated area, and use approved safety equipment, such as a dust mask that is specifically designed to filter out microscopic particles.

ELECTRICAL SAFETY



WARNING: To avoid electrical hazards, fire hazards or damage to the tool, use proper circuit protection.

This tool is wired at the factory for 120 Volts AC operation. It must be connected to a 120 Volts AC, 15 Amps circuit that is protected by a time-delayed fuse or circuit breaker. To avoid shock or fire, replace power cord immediately if it is worn, cut or damaged in any way.

SAVE THESE INSTRUCTIONS FOR REFERENCE

▲ WARNING: Read all safety warnings and all instructions. Failure to follow the warnings and instructions may result in electric shock, fire and/or serious injury.

Save all warnings and instructions for future reference.

Work area safety

Keep work area clean and well lit. Cluttered or dark areas invite accidents.

Do not operate power tools in explosive atmospheres, such as in the presence of flammable liquids, gases or dust. Power tools create sparks which may ignite the dust or fumes.

Keep children and bystanders away while operating a power tool. Distractions can cause you to lose control.

Electrical safety

Power tool plugs must match the outlet. Never modify the plug in any way. Do not use any adapter plugs with earthed (grounded) power tools. Unmodified plugs and matching outlets will reduce risk of electric shock.

Avoid body contact with earthed or grounded surfaces such as pipes, radiators, ranges and refrigerators. There is an increased risk of electric shock if your body is earthed or grounded.

Do not expose power tools to rain or wet conditions. Water entering a power tool will increase the risk of electric shock.

Do not abuse the cord. Never use the cord for carrying, pulling or unplugging the power tool. Keep cord away from heat, oil, sharp edges or moving parts. Damaged or entangled cords increase the risk of electric shock.

When operating a power tool outdoors, use an extension cord suitable for outdoor use. Use of a cord suitable for outdoor use reduces the risk of electric shock.

If operating a power tool in a damp location is unavoidable, use a residual current device (RCD) protected supply. Use of a ground fault circuit interrupter (GFCI) protected supply. Use of a ground fault circuit interrupter (GFCI) reduces the risk of electric shock.

Personal safety

Stay alert, watch what you are doing and use common sense when operating a power tool. Do not use a power tool while you are tired or under the influence of drugs, alcohol or medication. A moment of inattention while operating power tools may result in serious personal injury.

Use personal protective equipment. Always wear eye protection. Protective equipment such as dust mask, non-skid safety shoes, hard hat, or hearing protection used for appropriate conditions will reduce personal injuries.

Prevent unintentional starting. Ensure the switch is in the off-position before connecting to power source and/or battery pack, picking up or carrying the tool. Carrying power tools with your finger on the switch or energizing power tools that have the switch on invites accidents.

Remove any adjusting key or wrench before turning the power tool on. A wrench or a key left attached to a rotating part of the power tool may result in personal injury.

Do not overreach. Keep proper footing and balance at all times. This enables better control of the power tool in unexpected situations.

SAVE THESE INSTRUCTIONS FOR REFERENCE

POWER TOOL SAFETY

PERSONAL SAFETY – cont'd

Dress properly. Do not wear loose clothing or jewelry. Keep your hair, clothing and gloves away from moving parts. Loose clothes, jewelry or long hair can be caught in moving parts.

If devices are provided for the connection of dust extraction and collection facilities, ensure these are connected and properly used. Use of dust collection can reduce dust-related hazards.

Power tool use and care

Do not force the power tool. Use the correct power tool for your application. The correct power tool will do the job better and safer at the rate for which it was designed.

Do not use the power tool if the switch does not turn it on and off. Any power tool that cannot be controlled with the switch is dangerous and must be repaired.

Disconnect the plug from the power source and/or the battery pack from the power tool before making any adjustments, changing accessories, or storing power tools. Such preventive safety measures reduce the risk of starting the power tool accidentally.

Store idle power tools out of the reach of children and do not allow persons unfamiliar with the power tool or these instructions to operate the power tool. Power tools are dangerous in the hands of untrained users.

Maintain power tools. Check for misalignment or binding of moving parts, breakage of parts and any other condition that may affect the power tool's operation. If damaged, have the power tool repaired before use. Many accidents are caused by poorly maintained power tools.

Keep cutting tools sharp and clean. Properly maintained cutting tools with sharp cutting edges are less likely to bind and are easier to control.

Use the power tool, accessories and tool bits etc. in accordance with these instructions, taking into account the working conditions and the work to be performed. Use of the power tool for operations different from those intended could result in a hazardous situation.

Hold power tools by insulated gripping surfaces when performing an operation where cutting tool may contact hidden wiring or its own cord. Contact with a "live" wire will make exposed metal parts of the tool "live" and shock the operator

Service

Have your power tool serviced by a qualified repair person using only identical replacement parts. This will ensure that the safety of the power tool is maintained.

SAVE THESE INSTRUCTIONS FOR REFERENCE

SPECIFIC SAFETY RULES

▲ WARNING: Know your Plunge cut circular saw. Do not plug the saw into the power source until you have read and understand this Instruction Manual. Learn the tool's applications and limitations, as well as the specific potential hazards related to this tool. Following this rule will reduce the risk of electric shock, fire, or serious injury.



Always wear eye protection. Any power tool can throw foreign objects into your eyes and cause permanent eye damage.

ALWAYS wear safety goggles (not glasses) that comply with ANSI safety standard Z87.1. Everyday glasses have only impact resistant lenses. They ARE NOT safety glasses.

WARNING: Glasses or goggles not in compliance with ANSI Z87.1 could cause serious injury when they break.

Always keep hands out of the path of the saw blade. Avoid awkward hand positions where a sudden slip could cause your hand to move into the path of the saw blade.

▲ DANGER: Keep hands away from cutting area and the blade. Keep your second hand on the tool. If both hands are holding the saw, they cannot be cut by the blade.

Do not reach underneath the workpiece. The guard cannot protect you from the blade below the workpiece.

Adjust the cutting depth according to the thickness of the workpiece. Less than a full tooth of the blade teeth should be visible below the workpiece or approximately 3/8" (10mm).

Never hold piece being cut in your hands or across your leg. Secure the workpiece to a stable platform. It is important to support the work properly to minimize body exposure, blade binding, or loss of control.

When ripping always use a straight edge guide. This improves the accuracy of cut and reduces the chance of the blade binding.

Hold power tool by insulated gripping surfaces when performing an operation where the cutting tool may contact hidden wiring or its own cord. Contact with a "live" wire will also make exposed metal parts of the power tool "live" and shock the operator.

Always use blades with the correct size and shape (diamond versus round) of arbour holes. Blades that do not match the mounting hardware of the saw will run eccentrically, causing loss of control.

Never use damaged or incorrect blade washers or bolt. The blade washers and bolt were specially designed for your saw, for optimum performance and safety of operation.

CAUSES AND OPERATOR PREVENTION OF KICKBACK.

Kickback is a sudden reaction to a pinched, bound or misaligned saw blade, causing an uncontrolled saw to lift up and out of the workpiece toward the operator;

When the blade is pinched or bound tightly by the kerf closing down, the blade stalls and the motor reaction drives the unit rapidly back toward the operator.

If the blade becomes twisted or misaligned in the cut, the teeth at the back edge of the blade can dig into the top surface of the wood causing the blade to climb out of the kerf and jump back toward the operator.

Kickback is the result of saw misuse and/or incorrect operating procedures or conditions and can be avoided by taking proper precautions as given below:

Maintain a firm grip with both hands on the saw and position your arms to resist kickback forces. Position your body to the left or right side of the blade, but not in line with the blade. Kickback could cause the saw to jump backwards, but kickback forces can be controlled by the operator, if proper precautions are taken.

SAVE THESE INSTRUCTIONS FOR REFERENCE

SPECIFIC SAFETY RULES

CAUSES AND OPERATOR PREVENTION OF KICKBACK – cont'd

When the blade is binding, or when interrupting a cut for any reason, release the trigger and hold the saw motionless in the material until the blade comes to a complete stop. Never attempt to remove the saw from the work or pull the saw backward while the blade is in motion or kickback may occur. Investigate and take corrective actions to eliminate the cause of blade binding.

When restarting a saw in the workpiece, center the saw blade in the kerf and check that saw teeth are not engaged into the material. If the saw blades are binding, it may walk up or kickback from the workpiece as the saw is restarted.

Support large panels to minimize the risk of blade pinching and kickback. Large panels tend to sag under their own weight. Supports must be placed under the panel on both sides, near the line of cut and near the edge of the panel.

Do not use dull or damaged blades.

Unsharpened or improperly set blades produce narrow kerf causing excessive friction, blade binding and kickback.

ADDITIONAL SPECIFIC SAFETY RULES

Use extra caution when making a "plunge cut" into existing walls or other blind areas. The protruding blade may cut objects that can cause kickback.

Check the lower guard for proper closing before each use. Do not operate the saw if the lower guard does not move freely and close instantly. Never clamp or tie the lower guard into the open position. If the saw is accidentally dropped, the lower guard may be damaged. Raise the lower guard with the retracting handle and make sure it moves freely and does not touch the blade or any other part in all depths of cuts.

Check the operation of the lower guard spring. If the guard and the spring are not

operating properly, they must be serviced before use. The lower guard may operate sluggishly due to damaged parts, gummy deposits, or a build-up of debris.

The lower guard should be retracted manually only for special cuts such as "plunge cuts" and "compound cuts". Raise lower guard by retracting handle and as soon as the blade enters the material, the lower guard must be released. For all other sawing, the lower guard should operate automatically.

Always observe that the lower guard is covering the blade before placing saw down on the bench or on the floor. An unprotected, coasting blade will cause the saw to walk backwards, cutting whatever is in its path. Be aware of the time it takes for the blade to stop after the switch is released.

Never operate the saw while it is being carried to another location. The blade guard may be open and potentially cause serious injury.

If the switch fails to turn the saw ON or OFF properly, stop using it immediately and have the saw switch repaired.

Always allow the saw to reach full speed before beginning the cut.

Never use the side of the blade for cutting. When making horizontal cuts, make sure the weight of the tool is not forcing the side of the blade to do the cutting. This will reduce the risk of kickback.

Make sure there are no nails or foreign objects in the area of the workpiece to be cut.

Never lay workpiece on hard surfaces like concrete, stone, etc. The protruding blade may cause tool to jump.

▲ DANGER: To avoid injury from accidental starting, always remove the plug from the power source before making any adjustments and before installing or removing a saw blade.

SAVE THESE INSTRUCTIONS FOR REFERENCE

SPECIFIC SAFETY RULES

ADDITIONAL SPECIFIC SAFETY RULES – cont'd

When replacing the blade, make sure the replacement blade is 6-1/2" in diameter and is rated for 6,000 RPM. Installing an incorrect blade will result in possible injury and poor cutting action.

After changing a blade or making adjustments, make sure the blade clamp screw is securely tightened. Loose blades and adjustment devices will be violently thrown.

Never touch the blade during or immediately after use. After use the blade is too hot to be safely touched with bare hands.

EXTENSION CORD SAFETY

⚠ WARNING: Keep the extension cord clear of the working area. Position the cord so it will not get caught on the workpiece, tools or any other obstructions while you are working with the power tool.

Make sure any extension cord used with this tool is in good condition. When using an extension cord, be sure to use one of heavy enough gauge to carry the current the tool will draw. An undersized cord will cause a drop in line voltage resulting in loss of power and overheating.

The table below shows the correct size to use according to cord length and nameplate ampere rating. If in doubt, use the next heavier gauge. The smaller the gauge number the heavier the cord.

Be sure your extension cord is properly wired and in good condition. Always replace a damaged extension cord or have it repaired by a qualified electrician before using it. Protect your extension cord from sharp objects, excessive heat and damp or wet areas.

Use a separate electrical circuit for your power tools. This circuit must not be less than 14 gauge wire and should be protected with either a 15A time delayed fuse or circuit breaker. Before connecting the power tool to the power source, make sure the switch is in the OFF position and the power source is the same as indicated on the nameplate. Running at lower voltage will damage the motor.

MINIMUM GAUGE (AWG) EXTENSION CORDS (120 V use only)					
Amperage rating		Total length			
More than	Not more than	25' (7.5 m)	50' (15 m)	100' (30 m)	150' (45 m)
0	6	18	16	16	14
6	10	18	16	14	12
10	12	16	16	14	12
12	16	14	12	Not Applicable	

SAVE THESE INSTRUCTIONS FOR REFERENCE

PRODUCT SPECIFICATIONS

PRODUCT SPECIFICATIONS	
Rating:	120 V AC, 60 Hz,
Amperes:	10 AMP
No load speed:	5200 RPM
Arbor:	5/8"
Blade:	6-1/2"
Guide rail size:	4 x (27-1/2" x 7")
Maximum cutting depth without track (90°)	56mm (2-1/8")
Maximum cutting depth without track (45°)	45mm(1-3/4")
Maximum cutting depth with track (90°)	50mm(1-7/8")
Maximum cutting depth with track (45°)	40mm(1-1/2")
Weight:	10.8 lb(4.9 kg)













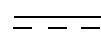





Need Assistance?
Call us on our toll free customer support line:
1-866-349-8665 Monday – Friday from 9am to 5pm
Eastern Standard Time

- Technical questions
- Replacement parts
- Parts missing from package

SAVE THESE INSTRUCTIONS FOR REFERENCE

SYMBOLS

⚠ WARNING: Some of the following symbols may appear on the saw. Study these symbols and learn their meaning. Proper interpretation of these symbols will allow for more efficient and safer operation of this tool.

V	Volts		Three-phase alternating current with neutral
A	Amperes		Read all safety warnings and instructions
Hz	Hertz		Direct current
W	Watts		No load speed
kW	Kilowatts		Alternating or direct current
μF	Microfarads		Class II construction
L	Litres		Splash-proof construction
kg	Kilograms		Watertight construction
H	Hours		Protective grounding at grounding terminal, Class I tools
N/cm ²	Newtons per square centimetre		Revolutions or reciprocations per minute
Pa	Pascals		Diameter
OPM	Oscillations per minute		Off position
Min	Minutes		Directional Arrow
S	Seconds		Warning symbol
 or a.c.	Alternating current		Wear your safety glasses
	Three-phase alternating current		Wear hearing protection



This symbol designates that this tool is listed with Canadian requirements by ETL Testing Laboratories, Inc. Conforms to UL Std. 60745-1 and 60745-2-5.

SAVE THESE INSTRUCTIONS FOR REFERENCE

KNOW YOUR PLUNGE CUT CIRCULAR SAW

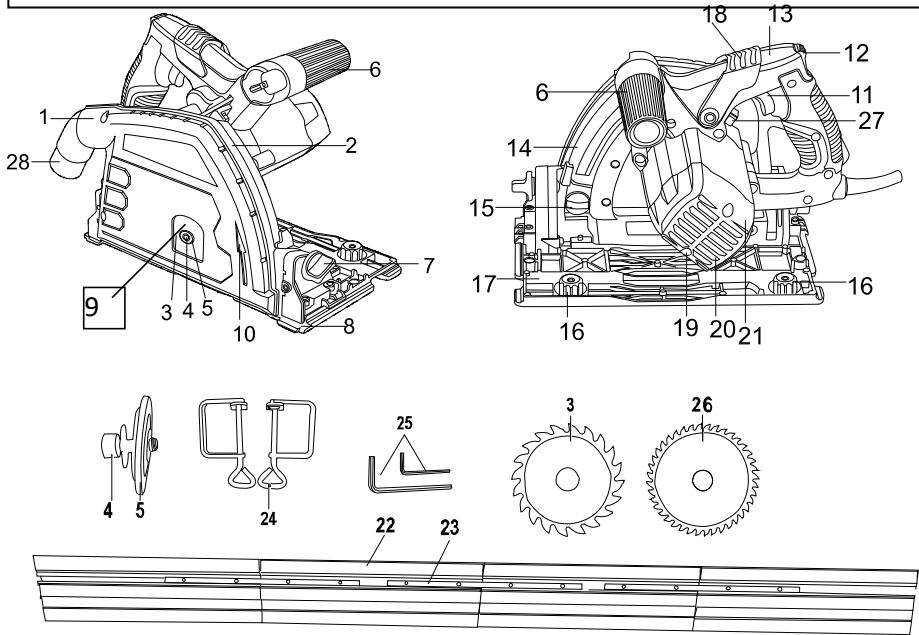

1. Dust port
2. Upper Guard
3. Blade 24T
4. Blade securing bolt
5. outer flange
6. Front handle
7. Angle adjustment lock knob
8. Base plate
9. Guard window
10. Direction indicator

11. On/Off trigger
12. Plunge release
13. Main handle
14. Depth scale
15. Depth locking knob
16. Track tension adjusters
17. Track channel
18. Safety button
19. Motor cover screw
20. Motor vents
21. Motor cover
22. Guide plate
23. Joining bar
24. Workpiece clamp
25. Hex. Key (3mm,5mm)
26. Blade 40T
27. Spindle locking lever
28. 1-1/4" dust adaptor

SAVE THESE INSTRUCTIONS FOR REFERENCE

ASSEMBLY AND OPERATING

INSTALLING THE BLADE

⚠ WARNING: Always remove the plug from the power source before installing or removing a blade or adjusting the saw in any way.

1. Place a clean piece of cardboard on a workbench to protect the blade and the workbench.
2. Push the plunge release (12), rotate the saw head clockwise until the blade securing bolt and the guard window are in same position. (Fig. 1)
3. Insert the 5 mm blade hex key into the blade securing bolt (4). (Fig. 1)
4. Press the spindle locking lever (27) (Fig. 2) and Rotate the blade hex screw counter clockwise and remove both the blade screw and the outer flange (5). (Fig.1)

NOTE: If the arbor turns with the blade screw, then press on the blade locking lever (27) and slowly rotate the blade screw until the locking lever engages the spindle (Fig. 2).

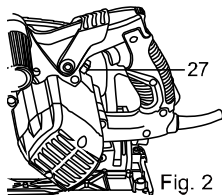
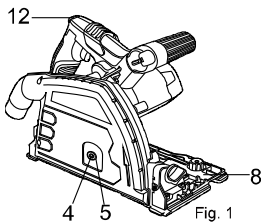

Blade 40T (see (26) in Know your Plunge cut circular saw on page 12)

– Fine wood blade for smooth clean cuts in wood and normal use in very light density woods and composite materials.

NOTE: Do NOT remove the inner flange (a) from the arbor (b). (see Fig.3)

5. Slide the blade upward through the slot in the base plate and place the blade hole onto the arbor.

NOTE: Make sure the blade teeth are pointing toward the front of the saw.

6. Place the outer flange (5) onto the arbor and thread the blade screw (4) into the arbour. (Fig. 1)
7. Tighten the blade screw.

NOTE: Press on the spindle locking lever (27) and slowly rotate the blade screw clockwise until the locking lever engages the spindle. Continue to turn the blade screw clockwise until the blade is firmly tightened onto the spindle. (Fig. 2)

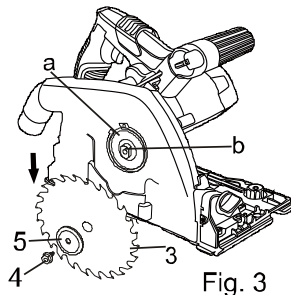

When installing a new blade, make sure you follow these precautions:

- a) Make sure the teeth at the bottom of the blade are pointing toward the front of the saw.
- b) Check the inner flange washer to make sure the thicker boss is pointing toward the motor.
- d) Make sure the flanged blade screw is NOT cross threaded and is fully tightened with the wrench provided.

The tool is supplied with 2 blades.

Blade 24T (see (3) in Know your Plunge cut circular saw on page 12)

– Coarse wood blade suitable for fast coarse cutting of wood and light density composite materials (comes installed on tool) (Fig. 3)

SAVE THESE INSTRUCTIONS FOR REFERENCE

ASSEMBLY AND OPERATING

e) Before turning the saw ON, carefully rotate the blade by hand to make sure it does not wobble.

DUST ADAPTOR

1. The Plunge cut circular saw is supplied with a dust adaptor for a vacuum. It is attached to the dust port located at the back end of the fixed guard.
2. Insert the dust adaptor to dust port until it fastens.(Fig. 4)
3. Use a 1-1/4" tube to connect the dust adaptor and vacuum to keep work area clean while cutting.

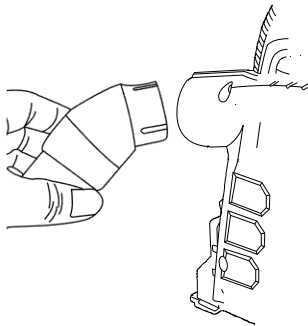

Fig. 4

TRIGGER SWITCH

1. To turn the saw ON, push forward the plunge release (12), then squeeze the ON/OFF trigger switch (11) (Fig. 5).

NOTE: Please ensure the safety button (18) is in the 'lock on' position before starting the tool, otherwise, if the safety button is in the 'lock off' position the tool will not start. (Fig. 5)

2. To turn the saw OFF, release the trigger switch.

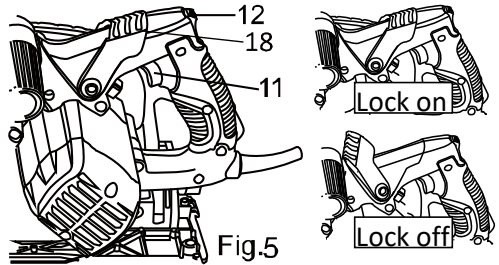

Fig.5

MATERIALS THAT YOU CAN CUT

The circular saw is a versatile saw that allows you to cut many different types of materials.

Some of the materials include:

- Wood products such as lumber, hardwood, plywood, composite board and panelling
- Drywall.
- Masonite and plastic.

NOTE: There are several different types of blades available. Generally, blades with carbide-tipped teeth cut better and stay sharp longer. Tooth count and configuration are also important. High tooth counts cut slower, and are best suited for making smooth cuts on thinner materials such as panelling. Use the correct blade for your application.

BEFORE YOU CUT

1. Make any adjustments to the saw before installing the blade.
2. Clearly mark the workpiece to locate the position of the cut.
3. Hold a smaller workpiece with a vise. Clamp a larger workpiece to a workbench or table

▲ DANGER: Any workpiece that is not adequately clamped in place may come loose and cause serious injury. Never hold the workpiece in your hand.

SAVE THESE INSTRUCTIONS FOR REFERENCE

ASSEMBLY AND OPERATING

⚠ WARNING:

For safety reasons, the operator must read the sections of this Owner's Manual entitled "GENERAL SAFETY WARNINGS", "POWER TOOL SAFETY", "SPECIFIC SAFETY RULES", "EXTENSION CORD SAFETY" and "SYMBOLS" before using this circular saw.

Verify the following every time the Plunge Cut Circular Saw is used:

1. The blade is tight and sharp.
2. All adjustments are tight.
3. The workpiece is properly secured.
4. Safety glasses and hearing protection are being worn.

Failure to adhere to these safety rules can greatly increase the chances of serious injury.

WARNING: Never carry the saw with your finger on the trigger switch. The saw could be accidentally started and cause severe personal injury.

GENERAL CUTTING

1. Make sure there are no nails, screws, clamps or foreign materials in the path of the saw blade.
2. With both hands firmly gripping the saw, and with the blade NOT in contact with the surface to be cut, start the saw by squeezing the trigger switch.
3. Once the saw has reached full speed, place the front edge of the base plate on the workpiece and gradually bring the moving blade into contact with the workpiece at the appropriate location.

⚠ WARNING: DO NOT force the Plunge cut circular saw. Use only enough force to keep the blade cutting at full speed. Excessive pressure on the blade will cause it to slow down and overheat, resulting in poor cut quality and damage to the motor.

SAVE THESE INSTRUCTIONS FOR REFERENCE

PLUNGE CUTTING

⚠ WARNING: To avoid loss of control, damage to the blade or damage to the workpiece, always use extreme caution when making plunge cuts. It is not recommended to plunge cut any material other than wood.

1. To plunge cut inside the edges of a workpiece, clearly mark the cutting line on the workpiece.
2. Set the saw on the workpiece (1) so the base plate is flat on the workpiece (Fig. 6).
3. Align the saw blade with the cutting line (3).
4. Press the plunge release (12) and switch trigger (11) to start the saw and slowly lower the blade onto the workpiece to allow the blade to cut into the workpiece (Fig. 7). Allow the blade to cut through the wood.
5. Continue lowering the blade into the workpiece until the full cutting depth has been achieved. Continue sawing toward the cutting line and complete the cut as required.

NOTE: Make sure the saw blade is inside the area to be cut out.

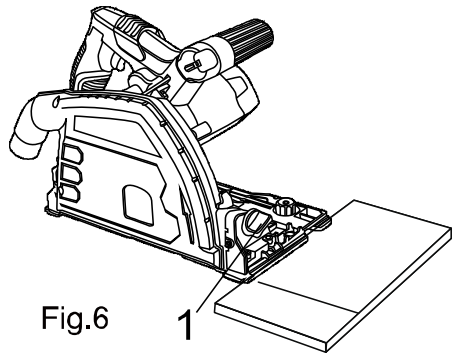

Fig.6

BEVEL CUTTING

Loosen both the angle adjustment lock knob (7) and tilt the tool to the desired angle for bevel cuts (0 -45°). Secure the lock knob (7) tightly after making the adjustment.

ASSEMBLY AND OPERATING

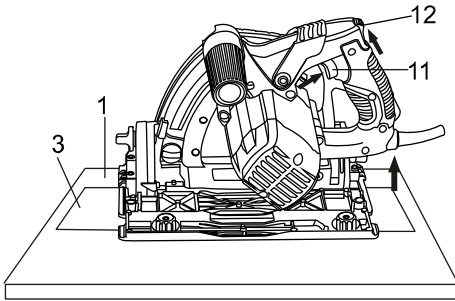

Fig.7

SETTING DEPTH ADJUSTMENT

Alter the depth of the cut by loosening the Depth Locking Knob (15), (Fig.8). The Base Plate (8) is now free to adjust to the required depth when the Plunge Release (12) is pressed. (Fig.7)

Adjust the Base Plate to the required depth using the Depth Scale (14) or a ruler and retighten the Depth Locking Knob at the base so it cannot exceed that depth. (Fig.8)

The symbol "I" is for depth limit line without track.

The symbol "II" is for depth limit line with track.

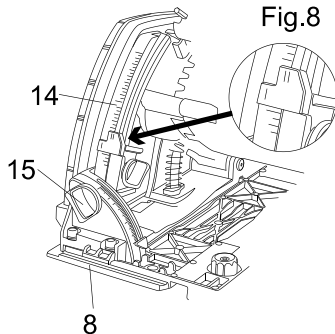

Fig.8

ASSEMBLING THE GUIDE TRACK

The aluminum guide track is used in conjunction with the Plunge cut circular saw to make precise cuts up to 110-1/4" (2.8 m). The guide track is shipped in four sections. To assemble the guide track, you will need a table or work bench at least 8' (2 m) long. Assemble the guide track as follows:

SAVE THESE INSTRUCTIONS FOR REFERENCE

1. Lay the track section (without joining bars) on its back toward the left hand side of the work surface.
2. Using the supplied hexagon key to loosen the 4 screws in the joining bar, Slide the cavities over the joining bar that is protruding from track section. (Fig.9, Fig.10)
3. Insert joining bar into the matching cavities in the left hand track section. (Fig.11)

NOTE: Do not tighten any screws until the guide track has been fully assembled.



Fig.9

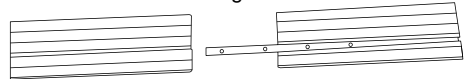

Fig.10



Fig.11

4. Repeat steps 2 and 3 to assemble the 3rd and 4th track section. (Fig.12)



Fig.12

5. Once all track sections are assembled, tighten all 12 screws.

NOTE: It is important to ensure that the fully assembled guide track forms a straight line for cutting. Turning the guide track assembly on its edge on a flat table or workbench will help in aligning all four sections as they are tightened. Once all screws are fully tightened, recheck the assembly with a straight edge. Loosen and retighten the screws as required to properly align all sections of the guide track assembly.

ASSEMBLY AND OPERATING

CUTTING USING THE GUIDE TRACK

The guide track can be used to make precision cuts on workpieces up to 110-1/4" (2.8 m).

1. Place workpiece on a table.
2. Mark the cut line (1) on the workpiece (Fig. 13).

NOTE: The guide track alignment mark placement will vary depending upon the type of blade being used. Always make a test cut on a scrap workpiece to verify the set-back distance.

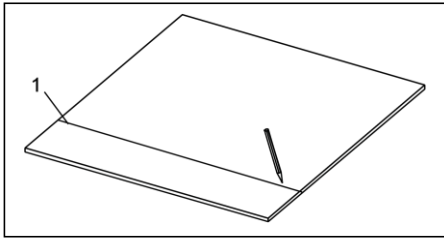

Fig. 13

3. Place the guide track (2) on the workpiece. Line up cutting edge of track with the cut line (1) (Fig 14).

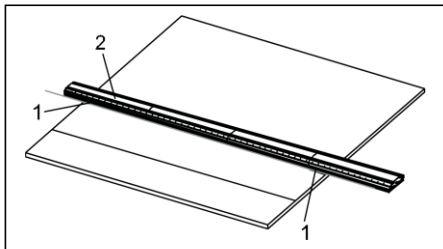

Fig. 14

4. Place the clamp (4) on the left hand side of the guide track at each end to hold it firmly onto the workpiece with the left edge on the guide track alignment marks (1). (Fig.15)

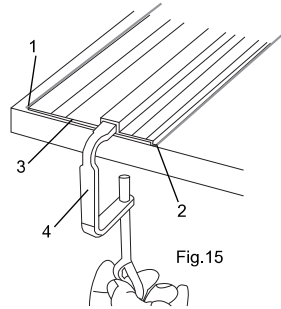

Fig.15

5. Set the saw cutting depth (see page 16, section of SETTING DEPTH ADJUSTMENT).
6. Place the saw on the guide track, the rear cover of the saw near the alignment marks (2), the blade near the cutting line (1). The track features two low friction strips (3) to allow smooth movement of the saw along the track. (Fig.16)

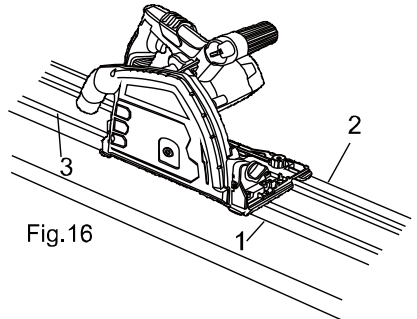

Fig.16

7. Set the Track Tension Adjusters (16) to the minimum tensions setting before placing the saw onto the track. (Fig.17)

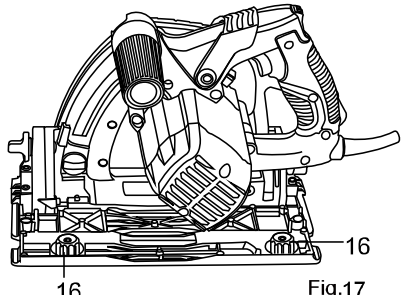

Fig.17

SAVE THESE INSTRUCTIONS FOR REFERENCE

MAINTENANCE

8. Use the Track Tension Adjusters to control movement resistance of the saw along the track. Set them to equal tension at the maximum level that allows smooth movement along the track. This will reduce or eliminate sideways movement for more precise cuts and improved safety.

NOTE: Make sure the blade does NOT contact the workpiece.

9. Turn the saw ON and slide the saw to cut.

GENERAL

▲ WARNING: When servicing, use only identical replacement parts. The use of any other part may create a hazard or cause product damage.

DO NOT use solvents when cleaning plastic parts. Plastics are susceptible to damage from various types of commercial solvents and may be damaged by their use. Use a clean cloth to remove dirt, dust, oil, grease etc.

▲ WARNING: Do not allow brake fluids, gasoline, petroleum-based products, penetrating oils, etc. to come into contact with plastic parts. They contain chemicals that can damage, weaken or destroy plastic.

DO NOT abuse power tools. Abusive practices can damage the tool and the workpiece.

▲ WARNING: DO NOT attempt to modify tools or create accessories. Any such alteration or modification is misuse and could result in a hazardous condition leading to possible serious injury. It will also void the warranty.

It has been found that electric tools are subjected to accelerated wear and possible premature failure when they are used on fiberglass boats and sports cars, wallboard, spackling compounds or plaster. The chips and grindings from these materials are highly abrasive to electric tool parts such as bearings, brushes, commutators, etc. Consequently, it is

not recommended that this tool be used for extended work on any fiberglass material, wallboard, spackling compounds or plaster. During any use on these materials it is extremely important that the tool is cleaned frequently by blowing it out with an air jet.

▲ WARNING: Always wear safety goggles or safety glasses with side shields during all cutting operations. It is critical that you also wear safety goggles or safety glasses with side shields and a dust mask while blowing dust out of the circular saw with an air jet. Failure to take these safety precautions could result in permanent eye or lung damage.

LUBRICATION

All of the bearings in this tool are lubricated with a sufficient amount of high-grade lubricant for the life of the unit under normal conditions. Therefore, no further lubrication is required.

REPLACING CARBON MOTOR BRUSHES

The carbon motor brushes will wear down and require replacing. The time intervals between replacements will vary depending upon the hours of use. It is recommended that the brushes be checked after each 10 hours of use.

▲ WARNING: Unplug the tool from the power source before replacing brushes.

1. Use a Philips (+) cross screwdriver (1) and remove the motor rear cover. (Fig. 18)
2. Remove the brush clamp plate (2).(Fig.19)
3. Remove the carbon brush connection wire (3) from brush terminal (4).(Fig.20)
4. Remove the carbon brush holder (5) with the carbon brush from the motor housing (6). (Fig.21)
5. Remove the carbon brush (6) from the brush holder (5).(Fig.22-23)
6. Reverse the process above to insert the carbon motor brushes back into the tool

SAVE THESE INSTRUCTIONS FOR REFERENCE

MAINTENANCE

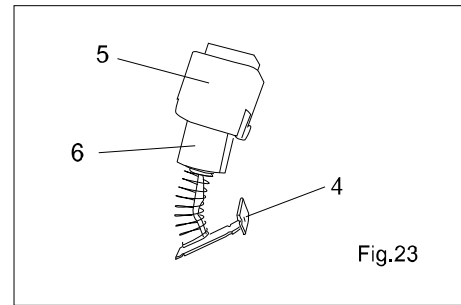
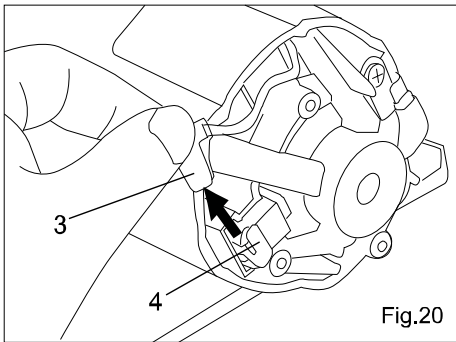
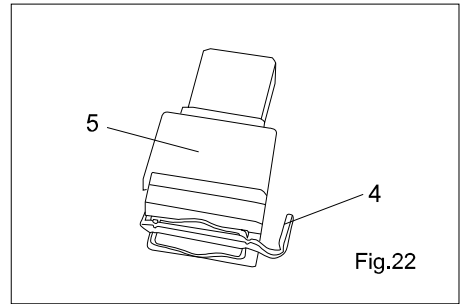
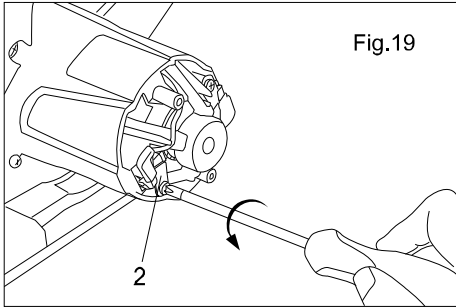
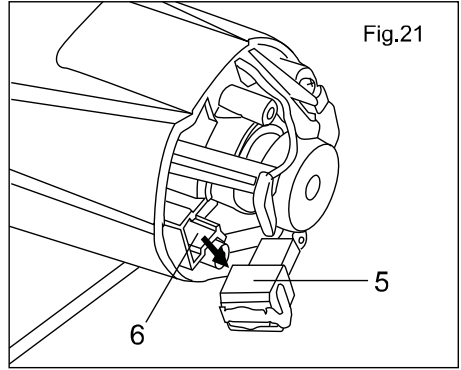
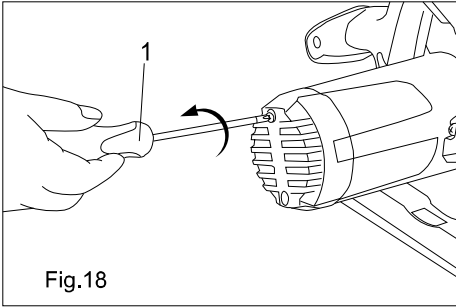

SAVE THESE INSTRUCTIONS FOR REFERENCE

EXPLODED VIEW

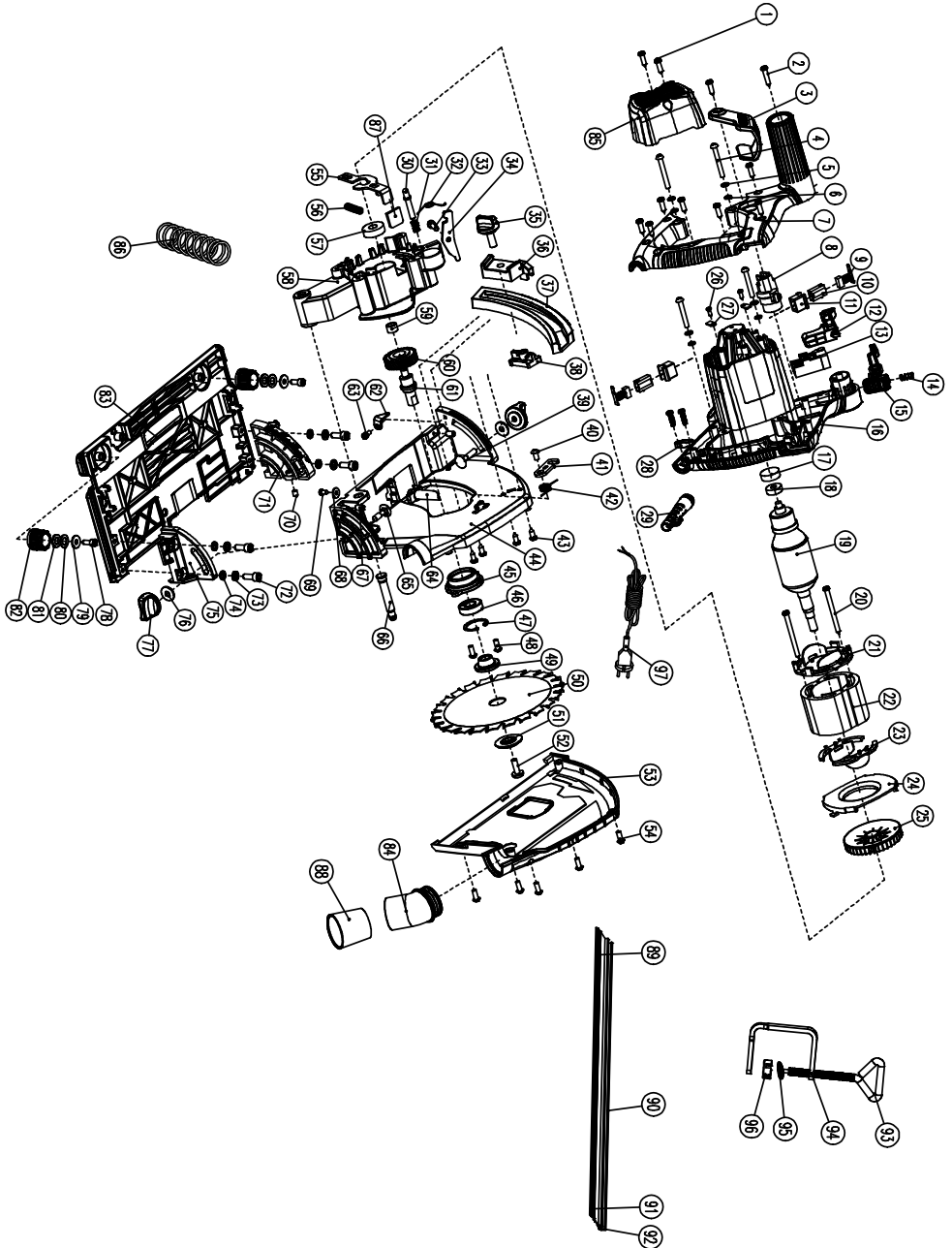

PARTS LIST

▲ WARNING: When servicing, use only original equipment replacement parts. The use of any other parts may create a safety hazard or cause damage to the saw.

Any attempt to repair or replace electrical parts on this saw may create a safety hazard unless repairs are performed by a qualified technician. For more information, call the Toll-free Helpline, at 1-866-349-8665.

Always order by PART NUMBER, not by key number.

Key #	Part #	Part Name	Quantity
1	241-0706-1	Tapping screw ST4.1x16-F	12
2	241-0706-2	Tapping screw ST4.1x32-F	8
3	241-0706-3	Lock knob	1
4	241-0706-4	Pub head screw M5x45	2
5	241-0706-5	small washer Ø5	2
6	241-0706-6	Spring washer Ø5	2
7	241-0706-7	Handle	1
8	241-0706-8	Lock wheel	1
9	241-0706-9	Carbon brushes	2
10	241-0706-10	Bush	2
11	241-0706-11	brush holder	2
12	241-0706-12	trigger	1
13	241-0706-13	switch	1
14	241-0706-14	spring	1
15	241-0706-15	push lever	1
16	241-0706-16	housing	1
17	241-0706-17	bush sleeve	1
18	241-0706-18	bearing 607 RS(7x19x6)	1
19	241-0706-19	Rotor	1
20	241-0706-20	Pan head tapping screw ST4.1x65-F	2
21	241-0706-21	Insulation plate of stator	2
22	241-0706-22	stator	1
23	241-0706-23	insulation end-plate	2
24	241-0706-24	wind guard	1
25	241-0706-25	fan	1
26	241-0706-26	tapping screw ST2.9x10-F	2
27	241-0706-27	brush holder cap	2
28	241-0706-28	cord pressure plate	1
29	241-0706-29	Cord guard	1
30	241-0706-30	depth lock pin	1
31	241-0706-31	torque spring	1
32	241-0706-32	torque spring	1
33	241-0706-33	Bolt M5x20	1
34	241-0706-34	fixed position plate	1
35	241-0706-35	lock knob	1
36	241-0706-36	indicator	1
37	241-0706-37	depth scaler	1
38	241-0706-38	indicator base	1
39	241-0706-39	Bolt M6x33	1
40	241-0706-40	Bolt M5x12	1
41	241-0706-41	lock plate	1

42	241-0706-42	spring of lock plate	1
43	241-0706-43	Tapping screw ST4.1x12-F	4
44	241-0706-44	blade guard	1
45	241-0706-45	gear box cover	1
46	241-0706-46	ball bearing 6001-2RS (40x17x12)	1
47	241-0706-47	Circlip for shaft 28	1
48	241-0706-48	Tapping screw M5x12	2
49	241-0706-49	blade base	1
50	241-0706-50	saw blade	1
51	241-0706-51	flange	1
52	241-0706-52	bolt M8x20	1
53	241-0706-53	blade guard cover	1
54	241-0706-54	Tapping screw M4x12	5
55	241-0706-55	spindle lock button	1
56	241-0706-56	spring	1
57	241-0706-57	bearing 6000 RS(8x22x7)	1
58	241-0706-58	gear box	1
59	241-0706-59	bush	1
60	241-0706-60	big gear	1
61	241-0706-61	spindle	1
62	241-0706-62	bevel indicator	1
63	241-0706-63	bolt M4x6	1
64	241-0706-64	spring base	1
65	241-0706-65	bolt M6x22	1
66	241-0706-66	tum shaft	1
67	241-0706-67	bolt M6x12	2
68	241-0706-68	washer	1
69	241-0706-69	Tapping screw ST3.5x9-F	1
70	241-0706-70	bolt M6x6	1
71	241-0706-71	bracket (front)	1
72	241-0706-72	bolt M6x20	4
73	241-0706-73	washer	4
74	241-0706-74	spring washer	4
75	241-0706-75	bracket (rear)	1
76	241-0706-76	washer	2
77	241-0706-77	Lock knob	2
78	241-0706-78	Bolt M5x12	2
79	241-0706-79	washer	2
80	241-0706-80	wave washer	2
81	241-0706-81	small washer	2
82	241-0706-82	adjustable knob	2
83	241-0706-83	base plate	1
84	241-0706-84	dust tube	1
85	241-0706-85	rear cover	1
86	241-0706-86	lift spring	1
87	241-0706-87	spindle lock sleeve	1
88	241-0706-88	dust tube adaptor	1
89	241-0706-89	Guide track	1
90	241-0706-90	Friction strip	2
91	241-0706-91	Guide track rubber bar	1
92	241-0706-92	antislip strip	2
93	241-0706-93	Lock lever	1
94	241-0706-94	Lock block	1
95	241-0706-95	clamp plate	1
96	241-0706-96	clamp plate pad	1
97	241-0706-97	power cord	1



MASTERFORCE® 6 1/2" PLUNGE CUT CIRCULAR SAW WARRANTY

90-DAY MONEY BACK GUARANTEE:

This MASTERFORCE® brand power tool carries our 90-Day Money Back Guarantee. If you are not completely satisfied with your MASTERFORCE® brand power tool for any reason within ninety (90) days from the date of purchase, return the tool with your original receipt to any MENARDS® retail store, and we will provide you a refund – no questions asked.

3-YEAR LIMITED WARRANTY:

This MASTERFORCE® brand power tool carries our famous No Hassle 3-Year Limited Warranty to the original purchaser. If, during normal use, this MASTERFORCE® power tool breaks or fails due to a defect in material or workmanship within three (3) years from the date of original purchase, simply bring the tool with the original sales receipt back to your nearest MENARDS® retail store. At its discretion, MASTERFORCE® agrees to have the tool or any defective part(s) repaired or replaced with the same or similar MASTERFORCE® product or part free of charge, within the stated warranty period, when returned by the original purchaser with original sales receipt. Notwithstanding the foregoing, this limited warranty does not cover any damage that has resulted from abuse or misuse of the Merchandise. This warranty: (1) excludes expendable parts including but not limited to blades, brushes, belts, bits, light bulbs, and/or batteries; (2) shall be void if this tool is used for commercial and/or rental purposes; and (3) does not cover any losses, injuries to persons/property or costs. This warranty does give you specific legal rights and you may have other rights, which vary from state to state. Be careful, tools are dangerous if improperly used or maintained. Seller's employees are not qualified to advise you on the use of this Merchandise. Any oral representation(s) made will not be binding on seller or its employees. The rights under this limited warranty are to the original purchaser of the Merchandise and may not be transferred to any subsequent owner. This limited warranty is in lieu of all warranties, expressed or implied including warranties of merchantability and fitness for a particular purpose. Seller shall not be liable for any special, incidental, or consequential damages. The sole exclusive remedy against the seller will be for the replacement of any defects as provided herein, as long as the seller is willing or able to replace this product or is willing to refund the purchase price as provided above. For insurance purposes seller is not allowed to demonstrate any of these power tools for you.

For questions / comments, technical assistance or repair parts –
Please call toll free at: 1-866-349-8665 (M-F 9am – 5pm).

**SAVE YOUR RECEIPTS
THIS WARRANTY IS VOID WITHOUT THEM**

MASTERFORCE[®]

MENARDS[®]

© 2016 Menard, Inc., Eau Claire, WI 54703

26/06/2017