

# BENCHMARK<sup>TM</sup> MC

## PNEUMATIC HAMMER



5 Year Limited Warranty

**READ ALL INSTRUCTIONS BEFORE FIRST USE.  
KEEP THIS MANUAL FOR FUTURE REFERENCE.  
KEEP AWAY FROM CHILDRE**



**WEAR CSA APPROVED  
EYE PROTECTION**



**WEAR EAR  
PROTECTION**



**WEAR A  
FACE MASK**

## PRODUCT SPECIFICATIONS

PNEUMATIC HAMMER	
Chisel shank	Round .401" (10.2mm)
Stroke Length	2.6" (66mm)
Bore diameter	3/4" (19 mm)
Blows per minute	3500 BPM
Maximum Air Pressure	90
Average air consumption	4 CFM @ 90PSI
Working pressure	90 psi
Air inlet size	1/4" NPT
Recommended hose	3/8" (9.5mm)
Weight	3.9lbs (1.8kg)

•Please note (where the 1/4" NPT connector is not already installed on the tool) your tool may be shipped with a black plastic cap installed in the air inlet. Pry the cap out prior to installing the 1/4" NPT connector.

### NEED ASSISTANCE?

Call us on our toll-free customer support line:

1-866-349-8665 (Monday through Friday 9am – 5pm Eastern Standard Time)

- Technical questions
- Replacement parts
- Parts missing from package

 **NOTE** these instructions pertain to the tool only. Please refer to your compressors operator's manual and follow the manufactures instructions.

**TABLE OF CONTENTS**

Product Specifications..... 1  
Table of Contents..... 2  
Safety Guidelines.....3-6  
Symbols..... 7  
Tool Specific Warnings..... 7  
Know your Pneumatic hammer .....8  
Assembly and Operating ..... 9-12  
Maintenance ..... 13-15  
Exploded View ..... 16  
Parts List ..... 17  
Warranty..... 18

## SAFETY GUIDELINES

### **WARNING:**

This manual contains information that relates to PROTECTING PERSONAL SAFETY and PREVENTING EQUIPMENT PROBLEMS. It is very important to read this manual carefully and understand it thoroughly before using the product. The symbols listed below are used to indicate this information.



### **DANGER!**

Potential hazard that will result in serious injury or loss of life.



### **WARNING!**

Potential hazard that could result in serious injury or loss of life.









### **CAUTION!**

Potential hazard that may result in moderate injury or damage to equipment.

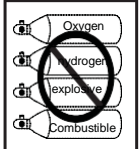
**Note** - The word " Note " is used to inform the reader of something he / she needs to know about the tool.

### **PERSONAL SAFETY**

These precautions are intended for the personal safety of the user and others working with the user. Please take time to read and understand them.

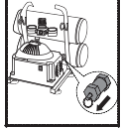
SYMBOL	MEANING
	<p><b>Do not use oxygen or any other combustible or bottled gas to power air-powered tools.</b> Failure to observe this warning can cause explosion and serious personal injury or death.</p> <p>Use only the compressed air to power the air-powered tools. Use a minimum of 25' (7.6 m) of hose to connect the tool to the compressor. Failure to comply will result in serious injury or loss of life.</p> 
	<p><b>Risk of electric shock:</b> Do not expose a compressor to rain. Store it indoors. Disconnect the compressor from power source before servicing. Compressor must be grounded. Do not use grounding adaptors.</p>
	<p><b>Risk of personal injury:</b> Do not direct compressed air from the air hose towards the user or other personnel.</p>
	<p><b>Risk for inhalation:</b> Never directly inhale the air produced by the compressor.</p>
	<p><b>Risk of bursting:</b> Do not adjust the pressure switch or safety valve for any reason. They have been preset at the factory for this compressor's maximum pressure. Tampering with the pressure switch or the safety valve may cause personal injury or property damage.</p>
	<p><b>Risk of burns.</b> The pump and the manifold generate high temperatures. In order to avoid burns or other injuries, do not touch the pump, the manifold, or the transfer tube while the compressor is running. Allow the parts to cool down before handling or servicing. Keep children away from the compressor at all times.</p>
	<p><b>Risk of bursting:</b> Make sure the regulator is adjusted so that the compressor outlet pressure is set lower than the maximum operating pressure of the tool. Before starting the compressor, pull the ring on the safety valve to make sure the valve moves freely. Drain water from tank after each use. Do not weld or repair tank. Relieve all pressure in the hose before removing or attaching accessories.</p> 



## DANGER!

- Keep children away from the work area. Do not allow children to handle power tools.
- Do not use this tool in the presence of flammable liquids or gases. Sparks that are created during use may ignite gases.
- Keep air hose away from heat, oil, and sharp edges. Check air hose for wear before each use and ensure that all connections are proper.
- Always ensure that the workpiece is firmly secured leaving both hands free to control the tool.
- Always ensure that the tool has stopped before putting it down after use, for safety purposes and to prevent possible damage to the tool/user.
- Keep proper footing at all times in order to ensure correct balance.



## WARNING!

- Do not allow unskilled or untrained individuals to operate the Gravity Feed Spray Gun.
- Locate the compressor in a well-ventilated area for cooling, and a minimum of 12" (31 cm) away from the nearest wall.  
Protect the air hose and the power cord from damage and puncture. Inspect them for weak or worn spots every week and replace them if necessary.
- Always wear hearing protection when using the air compressor. Failure to do so may result in hearing loss.  
Do not carry the compressor while it is running.
- Do not operate the compressor if it is not in a stable position.  
Do not operate the compressor on a rooftop or an elevated position that could allow the unit to fall or be tipped over.  
\*Always replace a damaged gauge before operating the unit again.  
\*Do not connect the tool to a source of compressed air with an outlet pressure greater than 90 PSI.



## CAUTION!

- Always ensure that the tool has stopped before disconnecting the air supply
- Do not wear watches, rings, bracelets, or loose clothing when using any air-powered tool
- Do not overload the tool. Allow the tool to operate at its optimum speed for maximum efficiency.
- Do not use a tool that is leaking air, that has missing or damaged parts, or that requires repairs. Verify that all screws are securely tightened
- For optimal safety and tool performance, inspect the tool before every usage, in order to ensure free movement of the trigger, safety mechanisms, and springs.
- Always keep your air tool clean and lubricated. Daily lubrication is essential to avoid internal corrosion and possible failures.
- Ensure the floor is not slippery and wear non-slip shoes. Floors should be kept clean and clear.
- Always follow all workshop safety rules, regulations, and conditions when using the tool and keep the work area clean.  
Carry the tool by the handle only, keeping fingers away from the trigger. Do not carry the tool by the hose, magazine, or any other parts.
- Do not use the tool near or below freezing point, as doing so may cause tool failure.
- Do not store the tool in a freezing environment to prevent ice formation on the tools operating valves, as doing so may cause tool failure.
- Handling and storage of oil: Use with adequate ventilation. Avoid contact of oil with eyes, skin, and clothing. Avoid breathing spray or mist. Store in a tightly closed container in a cool, dry, well-ventilated area free from incompatible substances.
- Tripping hazard. The air hose may become a tripping hazard when it is placed in the work area. Use care when walking in the work area.



## CAUTION!

• **Disconnect tool from the air supply and turn off the compressor** before performing any maintenance or changing accessories, when clearing a jammed fastener, when the tool is not in use, when it is being handed to another person, and when it is left unattended. Failure to comply may result in moderate injury or damage to equipment.

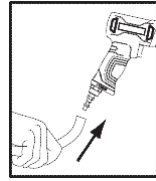

- **Use safety goggles and ear protection:** Wear safety glasses with side shields when operating the tool/compressor and verify that others in the work area are also wearing safety glasses. Safety glasses must conform to American National Standards Institute (ANSI Z87. 1) requirements and must provide protection from flying particles from the front and the sides. Air-powered tools are loud, and the sound can cause hearing damage. Always wear ear protection to prevent hearing damage and loss. Failure to comply may result in moderate injury.

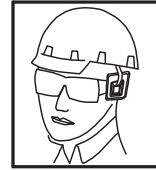

**NOTE:** Recycle unwanted materials rather than disposing of them as waste. Sort the tools, hoses, and packaging in specific categories and take to the local recycling center or dispose of in an environmentally safe way.

## SYMBOLS

**⚠️ WARNING:** Some of the following symbols may appear on the tool. Study these symbols and learn their meaning. Proper interpretation of these symbols will allow for more efficient and safer operation of this tool.

## SYMBOLS



**Read operator's manual:** To reduce the risk of injury, user must read and understand operator's manual before using this product.



**Risk to hearing:** Always wear ear protection when using this tool, failure to do so may result in hearing loss.



**Eye protection:** Always wear safety goggles, safety glasses with side shields, or a full face shield when operating this product.

## TOOL SPECIFIC WARNINGS

- Avoid direct contact with accessory and work surface during and after work as they become heated and sharp. Wear safety gloves to protect hands.
- Operators must be physically able to handle the bulk, weight, and power of tool. Do not force the tool.
- Repetitive work motions and exposure to vibration can be harmful to hands and arms. If numbness, tingling, pain or whitening of the skin occurs, stop using the tool.
- Stay clear of the hammer while in operation. Flying objects can cause severe injury.
- Avoid "free-running". This occurs when the tool is not in proper contact with the work, either sliding off or breaking through thin concrete or rock.
- Never use the hammer steel as a hand struck tool. They are designed for air hammers only.
- Select the correct shank and retainer for the tool being used.
- Never use dull accessories as they require excessive work pressure and can break.
- Always maintain a balanced body position and secure footing.
- Be aware of hidden hazards that may exist where you are working, such as electric wires etc.
- This tool is not intended for use in an explosive atmosphere.



# KNOW YOUR PNEUMATIC HAMMER

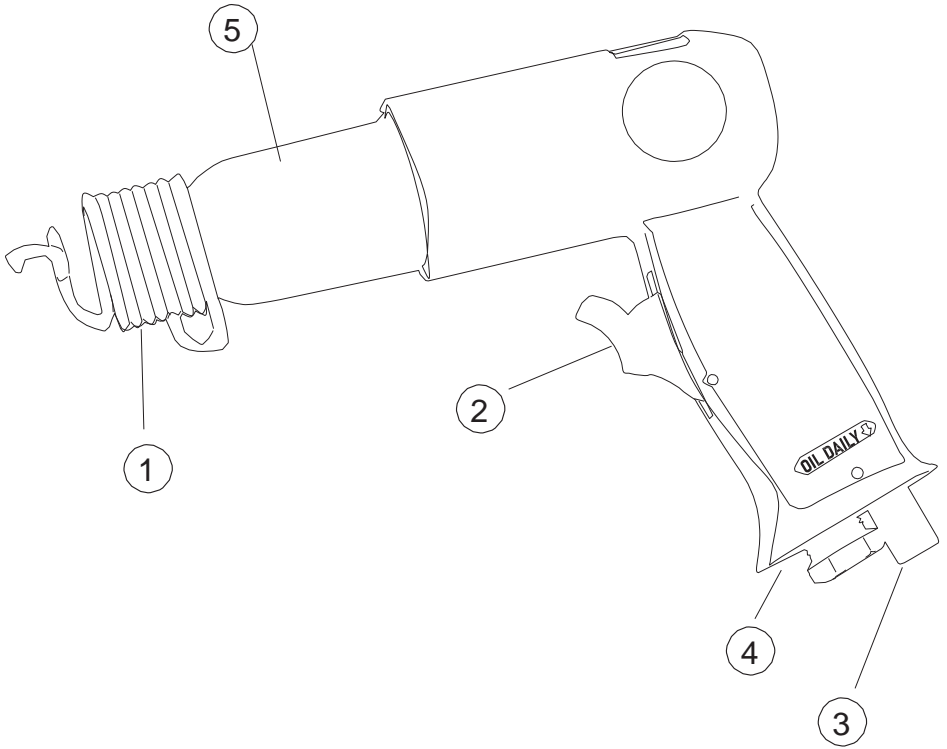

No.	Description	No.	Description
1	Quick-change retention spring	4	Air exhaust
2	Trigger	5	Chuck
3	Air inlet plug		

## ASSEMBLY AND OPERATING

The pneumatic hammer is ideal for cutting metal, removing fastener heads and other fabrication jobs. Constructed of lightweight die cast aluminum to reduce user fatigue during long jobs. Features include a positive action trigger and quick-change spring.

## COMPATIBLE COMPRESSORS GUIDELINES FOR PROPER USE AND OPERATION

Be sure to use a proper air compressor with air-powered tools. The compressor should be able to supply a minimal air delivery of 4 CFM @ 90 PSI to ensure the compressor can run continuously with the tool.

Air Compressor Size and Power	1 1/2-2 HP	2 1/2 HP	3+ HP
4-5 Gallons	Light-duty and Intermittent use	Light-duty and Intermittent use	Light-duty and Intermittent use
6-11 Gallons	Light-duty and Intermittent use	Medium-duty and Intermittent use	Medium-duty and Intermittent use
15+ Gallons	Medium-duty and Intermittent use	Heavy-duty and Continuous use	Heavy-duty and Continuous use

## **AIR SYSTEM**

Always use clean, dry, regulated, compressed air at 6.2bar(90PSI)

Do not exceed the maximum or minimum pressures. Operating the tool at the wrong pressure (too low or too high) will cause excessive noise or rapid wear of tool.

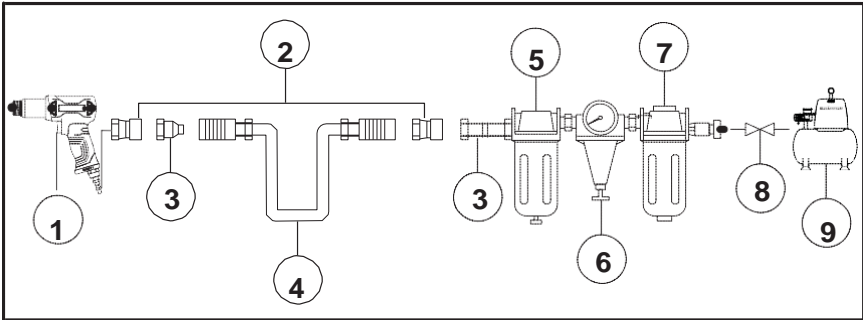

No.	Description	No.	Description
1	Air Hammer	6	0-90 PSI (0-6.2 bar)
2	Quick connector	7	Filter
3	Quick coupler	8	Cut-off valve
4	Air hose	9	Air compressor
5	Lubricator		

## **WARNING**

It is recommended that a filter-regulator-lubricator is used and located as close to the tool as possible.

If a filter-regulator-lubricator is not installed, place up to 6 drops of compressor oil into the NPT inlet plug before each use.

If a filter-regulator-lubricator is installed, keep the air filter clean. A dirty filter will reduce the air pressure to the tool, which will cause reduction in power, efficiency, and general performance.

For optimal performance, install a quick coupler in the hose, if applicable.

Verify that all of the connections in the air supply system are sealed in order to prevent air from leaking.

## **Air tools**

**Read this Instruction Manual carefully before using the tool** Read and follow all the safety instructions at the beginning of this manual. Inspect the air- powered tool prior to each use in order to:

-Ensure that the proper power source is being used.

-Verify that the tool is in proper working order.

-Verify that the air pressure level (s) are properly set on the air compressor. Do not use the tool if it is not in proper working order.

Do not use oxygen, CO<sub>2</sub> (carbon dioxide) or any other combustible, or bottled gas to power this tool.

Do not use this tool in the presence of any flammable liquids or gases.

Keep hands and other parts of the body away from the firing head during use. Do not point the tool towards the operator or other people.

**OPERATION**

1. Insert the desired chisel (1) into the chuck (2) (Fig. A).

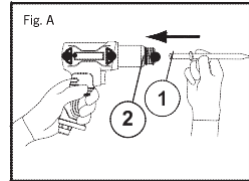

2. Insert the quick-change retention spring (1) around the chisel (2) in the chuck and tighten the quick-change retention spring (Fig. B).

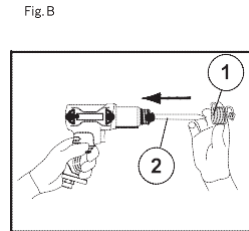

3. Plug in compressor, turn it on, set the pressure regulator to 90 PSI (6.3 bar), then attach one end of the air hose to the compressor and the other end of the air hose (1) to the tool (2). Use plumber's tape to avoid air leakage (Fig. C).

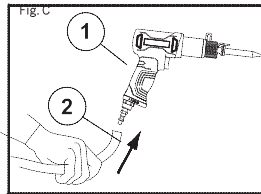

4. Press the trigger (1) to activate the chisel (Fig. D).

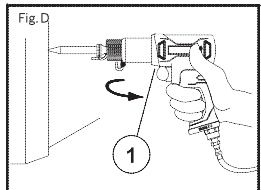

**Storage**

- If it is necessary to store the tool for an extended period of time, apply a generous amount of lubrication before storing.
- The tool should be allowed to run for approximately 30 seconds after lubricating, in order to ensure that the lubrication is uniformly distributed throughout the tool.

## Maintenance

**NOTE:** Do not store the tool anywhere temperatures will fall below freezing.



### **DANGER!**

Disconnect the tool from the air compressor before maintenance/service, adjusting, cleaning jams, reloading, and when it is not in use.

Repairs must be performed by a qualified service technician only.

Failure to comply will lead to serious injury or loss of life.

MAINTENANCE REQUIRED	DESCRIPTION	TOOLS OR MATERIALS REQUIRED	MAXIMUM SERVICE INTERVAL		
			Each use or every 2 hrs.	Monthly	As needed
General inspection - free movement	Trigger, spring,	None	X		
In-depth inspection	Worn or broken parts			X	X
Replace worn or broken parts					X
Lubrication	See below	Pneumatic tool oil	X		

Lubrication: If the tool and the compressor are not equipped with an in-line lubrication system, place up to six drops of pneumatic tool oil into the air inlet before each use or after every two hours of continuous use, depending on the characteristics of the workpiece.

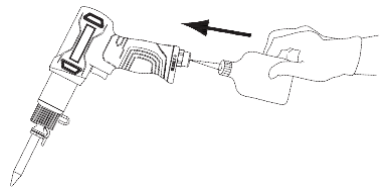

Air-operated tools must be inspected periodically, and worn or broken parts must be replaced to ensure that the tools are operating safely and efficiently.

Inspect and replace worn or damaged O-rings, seals, etc. Tighten all screws and caps frequently in order to help prevent personal injury.

Loss of power or erratic action may be due to the following

- Excessive drain in the air line.
- Moisture or restriction in the air pipe.
- Incorrect size or type of hose connector. Check the air supply and follow instructions.
- Grit or gum deposits in the Die Grinder may also reduce performance.

- Inspect the trigger, the spring, and the safety mechanism for free movement on a regular basis in order to ensure that the safety system is fully functional.
- Verify that no part is loose or missing and that no part is stuck or jammed.
- Disconnect the tool from the air supply, clean, and store it in a safe, dry, and childproof location, when tool is not in use.
- When temperatures are below freezing, keep tools as warm as possible using any safe, convenient method.
- Check the air supply for correct size and type of hose connectors. To avoid loss of power or erratic action, ensure that there is no additional drain on the air line and no moisture or restriction in the air pipe.

**Troubleshooting**

**⚠DANGER** If any of the following symptoms appear while the tool is in use, turn it off and disconnect it from the air supply immediately. Failure to comply will lead to serious injury or loss of life.

Disconnect the tool from the air supply before making any adjustments. Repairs must be performed by a qualified service technician only.

The following chart lists some common operating system issues and solutions. Please read it carefully and follow all instructions carefully.

<b>Problem</b>	<b>Possible causes</b>	<b>Solutions</b>
Tool runs at normal speed but loses power under load.	Motor parts are worn or damaged. Cam clutch is worn or stuck due to lack of lubricant.	Lubricate clutch housing. Check for excess clutch oil. Clutch cases should only be half filled, as overfilling can cause drag on high-speed clutch parts.  Grease lubrication: Heat is generated due to insufficient grease in the chamber. Severe operating conditions may require frequent lubrication.

<b>Problem</b>	<b>Possible causes</b>	<b>Solutions</b>
Tool runs at low speed. Air flows slightly from exhaust.	1. Motor parts are jammed with dirt. 2. Power regulator is in closed position.  Air flow is blocked by dirt.	Check if there is blockage in air inlet and filter.  Pour pneumatic tool oil into air inlet as per instructions.  Operate the tool by reversing rotation back and forth in a short duration. Repeat the above steps as needed.
Tool stops working. Air flows freely from exhaust.	One or more motor vanes are stuck due to material build up.	Pour pneumatic tool oil into the air inlet.  Tap motor housing gently with plastic mallet.  Operate the tool by reversing the rotation back and forth in short duration  (wherever applicable).  Disconnect the power supply.  Operate the motor manually by rotating the drive shank (wherever applicable).
Tool does not shut off.	Throttle valve O-rings are dislodged from seat inlet valve.	Replace O-rings.



**EXPLODED VIEW**

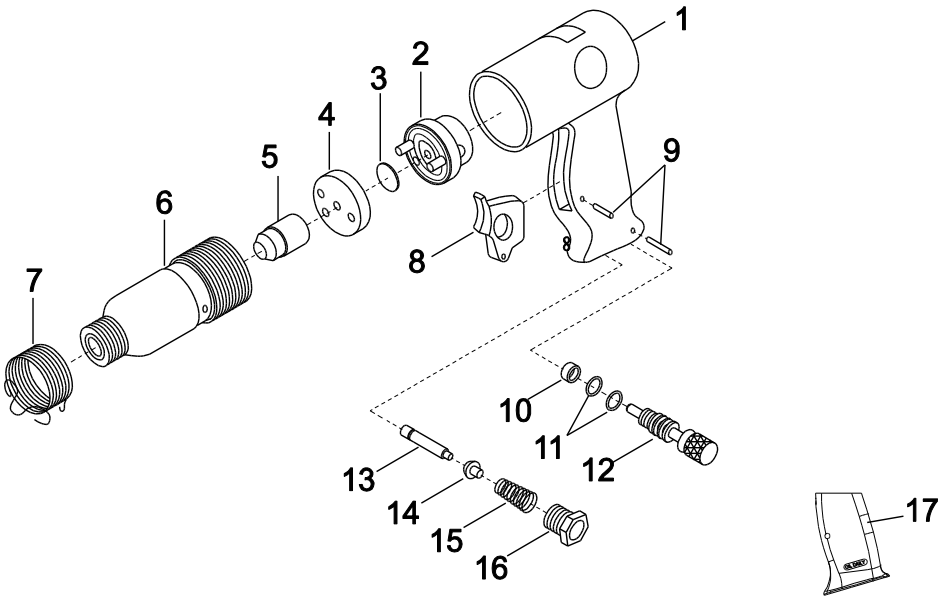

## PARTS LIST

**⚠ WARNING** When servicing, use only original equipment replacement parts. The use of any other parts may create a safety hazard or cause damage to the tool.

Any attempt to repair or replace electrical parts on this tool may create a safety hazard unless repairs are performed by a qualified technician. For more information, call the Toll-free Helpline, at 1-866-349-8665.

**Always order by PART NUMBER, not by key number.**

Key#	Part #	PartName	Qty
1	1282-701-001	HOUSING	1
2	1282-701-002	SEALING VALVE	1
3	1282-701-003	VALUE PLATE	1
4	1282-701-004	SEALING VALVE COVER	1
5	1282-701-005	PISTON	1
6	1282-701-006	CYLINDER	1
7	1282-701-007	SPRING	1
8	1282-701-008	TRIGGER	1
9	1282-701-009	STRAIGHT PIN	2
10	1282-701-010	THROTTLE VALVE	1
11	1282-701-011	O-RING	2
12	1282-701-012	ADJUSTING VALVE POLE	1
13	1282-701-013	PIN	1
14	1282-701-014	GAS ADMITTANCE VALVE	1
15	1282-701-015	TAPER SPRING	1
16	1282-701-016	AIR INLET CONNECTOR	1
17	1282-701-017	JACKET	2

## **WARRANTY**

### **BENCHMARK WARRANTY**

If this Benchmark tool fails due to a defect in material or workmanship within five years from the date of purchase, return it to any Home Hardware store with the original bill of sale for exchange. 3-year warranty for the battery and charger. This warranty does not include expendable parts including but not limited to blades, brushes, belts, light bulbs. This warranty covers defects in material or workmanship only. It does not cover normal wear and tear, failure due to abuse/misuse, or defects caused by careless or accidental mishandling. If this Benchmark product is used for commercial or rental purposes, this warranty does not apply.

# PNEUMATIC HAMMER



5 Year Limited Warranty

**BENCHMARK**<sup>MC</sup>

**BENCHMARK TOOLS CANADA**  
ST. JACOBS, ONTARIO N0B 2N0  
© 2021 Home Hardware Stores Limited

**CUSTOMER SERVICE/TECH SUPPORT**  
1-866-349-8665

**1282-701**

Made in China



\* This Benchmark™ product carries a five (5) year LIMITED warranty against defects in workmanship and materials. See Owner's Manual for full details.

**READ ALL INSTRUCTIONS BEFORE FIRST USE.  
KEEP THIS MANUAL FOR FUTURE REFERENCE.  
KEEP AWAY FROM CHILDREN.**



**WEAR CSA APPROVED  
EYE PROTECTION**



**WEAR EAR  
PROTECTION**



**WEAR A  
FACEMASK**