

Radley®

18 GAUGE PNEUMATIC BRAD NAILER OWNER'S MANUAL



*3 Year
warranty*

3 Year Limited Warranty



READ ALL INSTRUCTIONS BEFORE FIRST USE. KEEP THIS
MANUAL FOR FUTURE REFERENCE. KEEP AWAY FROM
CHILDREN.



WEAR CSA APPROVED
EYE PROTECTION



WEAR EAR
PROTECTION



WEAR FACE
PROTECTION

PRODUCT SPECIFICATIONS

AIR BRAD NAILER	
Magazine Capacity	100 Nails
Fastener Capacity	18 Gauge 5/8" - 2" Long
Max PSI	120PSI
Average Air Consumption	0.5 CFM @ 90PSI
Working pressure	60-100 PSI
Magazine angle	90°
Air inlet size	1/4" NPT
Recommended hose size	1/4" or 3/8"
Weight	3.08lb (1.4 kg)

Please note (where the 1/4" NPT connector is not already installed on the tool) your tool may be shipped with a black plastic cap installed in the air inlet. Pry the cap out prior to installing the 1/4" NPT connector.

NEED ASSISTANCE?

Call us on our toll-free customer support line:
1-866-349-8665 (Monday through Friday 9am – 5pm Eastern Standard Time)

- Technical questions
- Replacement parts
- Parts missing from package

 NOTE these instructions pertain to the tool only. Please refer to your compressors operator's manual and follow the manufactures instructions.

TABLE OF CONTENTS

Product Specifications 1
Table of Contents 2
Safety Guidelines..... 3-5
Symbols..... 6
Tool specific warnings..... 7
Know your 18-gauge pneumatic brad nailer..... 8
Assembly and Operating 9-14
Maintenance..... 15-18
Exploded View 19
Parts List..... 20-22
Warranty..... 23

SAFETY GUIDELINES

WARNING:

This manual contains information that relates to PROTECTING PERSONAL SAFETY and PREVENTING EQUIPMENT PROBLEMS. It is very important to read this manual carefully and understand it thoroughly before using the product. The symbols listed below are used to indicate this information.



DANGER!

Potential hazard that will result in serious injury or loss of life.



WARNING!

Potential hazard that could result in serious injury or loss of life.









CAUTION!

Potential hazard that may result in moderate injury or damage to equipment.

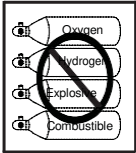
Note - The word " Note " is used to inform the reader of something he / she needs to know about the tool.

PERSONAL SAFETY

These precautions are intended for the personal safety of the user and others working with the user. Please take time to read and understand them.

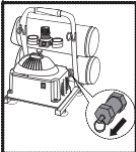
SYMBOL	MEANING
	<ul style="list-style-type: none"> Do not use oxygen or any other combustible or bottled gas to power air-powered tools. Failure to observe this warning can cause explosion and serious personal injury or death. Use only the compressed air to power the air-powered tools. Use a minimum of 25' (7.6 m) of hose to connect the tool to the compressor. Failure to comply will result in serious injury or loss of life. 
	<ul style="list-style-type: none"> Risk of electric shock: Do not expose a compressor to rain. Store it indoors. Disconnect the compressor from power source before servicing. Compressor must be grounded. Do not use grounding adaptors.
	<ul style="list-style-type: none"> Risk of personal injury: Do not direct compressed air from the air hose towards the user or other personnel.
	<ul style="list-style-type: none"> Risk of inhalation: Never directly inhale the air produced by the compressor.
	<ul style="list-style-type: none"> Risk of bursting: Do not adjust the pressure switch or safety valve for any reason. They have been preset at the factory for this compressor's maximum pressure. Tampering with the pressure switch or the safety valve may cause personal injury or property damage.
	<ul style="list-style-type: none"> Risk of burns. The pump and the manifold generate high temperatures. In order to avoid burns or other injuries, do not touch the pump, the manifold, or the transfer tube while the compressor is running. Allow the parts to cool down before handling or servicing. Keep children away from the compressor at all times.
	<ul style="list-style-type: none"> Risk of bursting: Make sure the regulator is adjusted so that the compressor outlet pressure is set lower than the maximum operating pressure of the tool. Before starting the compressor, pull the ring on the safety valve to make sure the valve moves freely. Drain water from tank after each use. Do not weld or repair tank. Relieve all pressure in the hose before removing or attaching accessories. 

DANGER!



- Keep children away from the work area. Do not allow children to handle power tools.
- Do not use this tool in the presence of flammable liquids or gases. Sparks that are created during use may ignite gases.
- Keep air hose away from heat, oil, and sharp edges. Check air hose for wear before each use and ensure that all connections are proper.
- Always ensure that the workpiece is firmly secured leaving both hands free to control the tool.
- Always ensure that the tool has stopped before putting it down after use, for safety purposes and to prevent possible damage to the tool/user.
- Keep proper footing at all times in order to ensure correct balance.
- Always assume that the tool contains fasteners.
- Do not point the tool toward yourself or anyone else.

WARNING!



- Do not allow unskilled or untrained individuals to operate the tool.
- Do not use the tool for any task other than that it is designed to perform.
- Locate the compressor in a well-ventilated area for cooling, and a minimum of 12" (31 cm) away from the nearest wall.
- Protect the air hose and the power cord from damage and puncture. Inspect them for weak or worn spots every week and replace them if necessary.
- Always wear hearing protection when using the air compressor. Failure to do so may result in hearing loss.
- Do not carry the compressor while it is running.
- Do not operate the compressor if it is not in a stable position.
- Do not operate the compressor on a rooftop or an elevated position that could allow the unit to fall or be tipped over.
- Always replace a damaged gauge before operating the unit again. Do not connect the tool to a compressed air source with a pressure output that is higher than 120 PSI.

CAUTION!



- Always ensure that the tool has stopped before connecting to the air supply.
- Do not wear watches, rings, bracelets, or loose clothing when using any air-powered tool.
- Do not overload the tool. Allow the tool to operate at its optimum speed for maximum efficiency.
- Do not use a tool that is leaking air, that has missing or damaged parts, or that requires repairs. Verify that all screws are securely tightened.
- For optimal safety and tool performance, inspect the tool daily in order to ensure free movement of the trigger, safety mechanisms, and springs.
- Always keep your air tool clean and lubricated. Daily lubrication is essential to avoid internal corrosion and possible failures.
- Ensure the floor is not slippery and wear non-slip shoes. Floors should be kept clean and clear.
- Always follow all workshop safety rules, regulations, and conditions when using the tool.
- Carry the tool by the handle only, keeping fingers away from the trigger. Do not carry the tool by the hose, magazine, or any other parts.
- Do not use the tool near or below freezing point, as doing so may cause tool failure.
- Do not store the tool in a freezing environment to prevent ice formation on the tools operating valves, as doing so may cause tool failure.
- Handling and storage of oil: Use with adequate ventilation. Avoid contact of oil with eyes, skin, and clothing. Avoid breathing spray or mist. Store in a tightly closed container in a cool, dry, well-ventilated area free from incompatible substances.
- Tripping hazard. The air hose may become a tripping hazard when it is placed in the work area. Use care when walking in the work area.

CAUTION!

- **Disconnect tool from the air supply and turn off the compressor** before performing any maintenance or changing accessories, when clearing a jammed fastener, when the tool is not in use, when it is being handed to another person, and when it is left unattended. Failure to comply may result in moderate injury or damage to equipment.

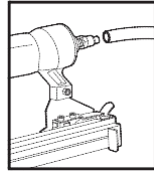

- **Use safety goggles and ear protection:** Wear safety glasses with side shields when operating the tool/compressor and verify that others in the work area are also wearing safety glasses. Safety glasses must conform to American National Standards Institute (ANSI Z87. 1) requirements and must provide protection from flying particles from the front and the sides. Air-powered tools are loud, and the sound can cause hearing damage. Always wear ear protection to prevent hearing damage and loss. Failure to comply may result in moderate injury.



Note: Recycle unwanted materials rather than disposing of them as waste. Sort the tools, hoses, and packaging in specific categories and take to the local recycling center or dispose of in an environmentally safe way.

SYMBOLS

⚠ WARNING: Some of the following symbols may appear on the tool. Study these symbols and learn their meaning. Proper interpretation of these symbols will allow for more efficient and safer operation of this tool.

SYMBOLS

Read operator's manual: To reduce the risk of injury, user must read and understand operator's manual before using this product.



Risk to hearing Always wear ear protection when using this tool. Failure to do so may result in hearing loss.



Eye protection: Always wear safety goggles, safety glasses with side shields, or a full-face shield when operating this product.

TOOL SPECIFIC WARNINGS

- Keep hands and other parts of the body away from the firing head during use. Keep hands, feet, and all other parts of the body at least 8"(20 cm) away from the firing head.
- Nails or objects in the workpiece can cause serious injury if they are deflected by the workpiece or if they are driven away from the point of entry.
- Do not overload the tool. Allow the tool to operate at its optimum speed for maximum efficiency.
- Disconnect the tool from the air supply and turn off the compressor before performing any maintenance, loading, or changing nails. when the tool is not in use, when it is being handed to another person, when it is left unattended.
- Failure to comply may result in injury or damage to the equipment.

KNOW YOUR 18 GAUGE PNEUMATIC BRAD NAILER

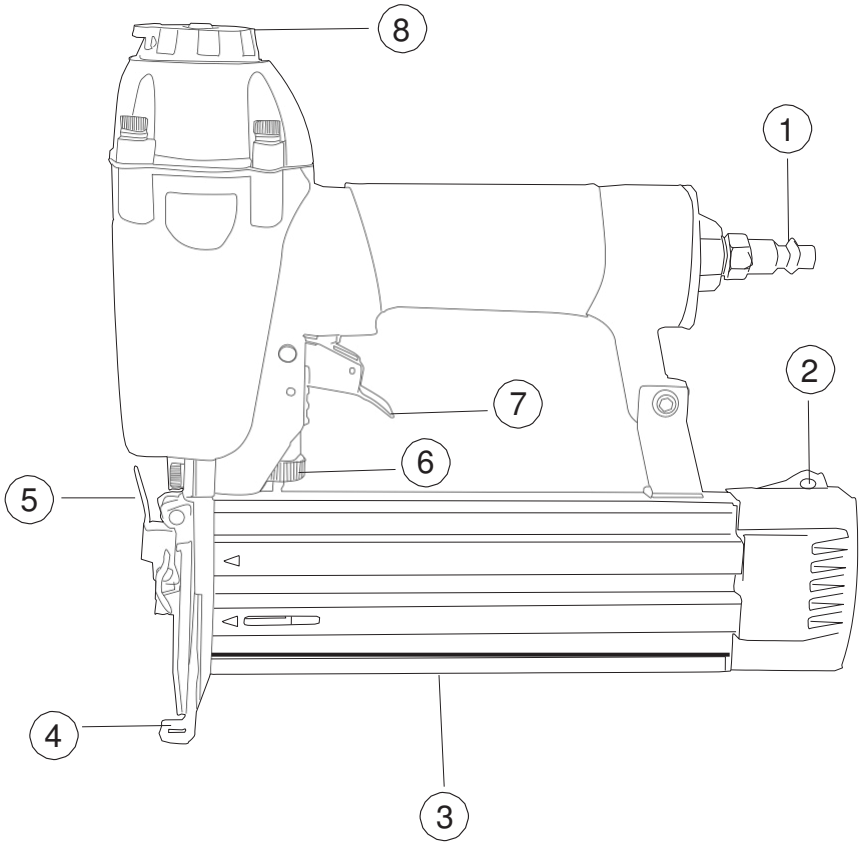

No.	Description	No.	Description
1	Air inlet plug	5	Quick nail extraction lever
2	Magazine latch	6	Depth adjustment dial
3	Magazine	7	Trigger
4	Workpiece Contact	8	Air deflector

ASSEMBLY AND OPERATING

The 18 Gauge pneumatic Brad Nailer is ideal for fastening all types of trim and molding around the house. The lightweight, narrow body tool is easy to handle, making it ideal for floor molding and cabinet trim. The brad nailer has a 100-brad magazine that fires 18-gauge brads from 5/8" to 2".

COMPATIBLE COMPRESSORS

GUIDELINES FOR PROPER USE AND OPERATION

Be sure to use a proper air compressor with air-powered tools. The compressor should be able to supply a minimal air delivery of 0.5 CFM @ 90 PSI to ensure the compressor can run continuously with the tool.

Air Compressor Size and Power	1/3–1 1/3 HP	1 1/2–2 HP	2+ HP
2–6 Gallons	Light-duty and Intermittent use	Light-duty and Intermittent use	Light-duty and Intermittent use
8-11 Gallons	Light-duty and Intermittent use	Medium-duty and Intermittent use	Medium-duty and Intermittent use
15+ Gallons	Medium-duty and Intermittent use	Heavy-duty and Continuous use	Heavy-duty and Continuous use

Wood Density	Nail Size	Compressor Air Pressure
>0.6g/cm ³	<2" (50 mm) brad nails	90-100 PSI (6.3-7 bar)
≤0.6g/cm ³	<2" (50 mm) brad nails	60-90 PSI (4-6.3 bar)

AIR SYSTEM

Always use clean, dry, regulated, compressed air at 4.1 to 6.9bar (60-100PSI)
Do not exceed the maximum or minimum pressures. Operating the tool at the wrong pressure (too low or too high) will cause excessive noise or rapid wear of tool.

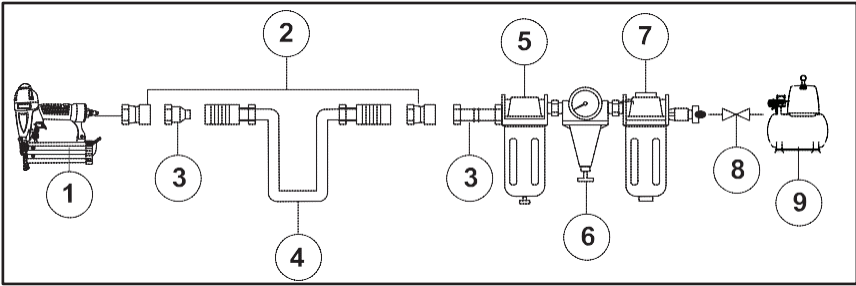

No.	Description	No.	Description
1	18-gauge pneumatic brad nailer	6	0 to 6.9 bar
2	Quick connector	7	Filter
3	Quick coupler	8	Cut-off valve
4	Air hose	9	Air compressor
5	Lubricator		

⚠ WARNING The use of any other types of fasteners will cause the tool to jam. Failure to comply could lead to serious injury or loss of life.

It is recommended that a filter-regulator-lubricator is used and located as close to the tool as possible.

If a filter-regulator-lubricator is not installed, place up to 6 drops of compressor oil into the NPT inlet plug before each use.

If a filter-regulator-lubricator is installed, keep the air filter clean. A dirty filter will reduce the air pressure to the tool, which will cause reduction in power, efficiency, and general performance.

For optimal performance, install a quick coupler in the hose, if applicable.

Verify that all of the connections in the air supply system are sealed in order to prevent air from leaking.

Air tools

Read this Instruction Manual carefully before using the tool

Read and follow all the safety instructions at the beginning of this manual. Inspect the air-powered tool prior to each use in order to:

- Ensure that the proper power source is being used.
- Verify that the tool is in proper working order.
- Verify that the air pressure level (s) are properly set on the air compressor.

Do not use the tool if it is not in proper working order.

Do not use oxygen, CO₂ (carbon dioxide) or any other combustible, or bottled gas to power this tool.

Do not use this tool in the presence of any flammable liquids or gases.

Keep hands and other parts of the body away from the firing head during use.

Do not point the tool towards the operator or other people.

Never attempt to clear a jammed fastener while the air hose is connected.

Do not drive a fastener on top of an existing fastener. Failure to comply could lead to serious injury or death.

ACCEPTABLE NAILS

Length: 5/8 - 2" (15 to 50 mm)

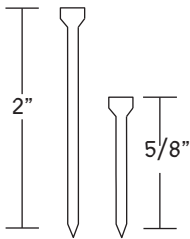

NAIL TYPE ICON

These Icons are used to select the proper nails for this specific nailer.



Loading nails

⚠ WARNING: Disconnect the tool from the compressed air source before loading fasteners. Do not point the tool towards the operator or other people while changing fasteners. Do not hold the tool with the trigger depressed while changing fasteners. Failure to comply will lead to serious injury or loss of life.

1. Disconnect the tool (1) from the air supply (2).

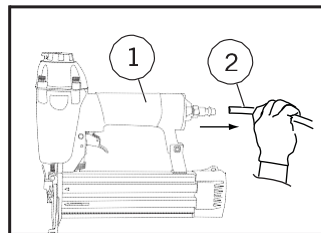

2. Hold the Brad Nailer firmly with one hand and use the other hand to press the latch (1) on the magazine (2) and slide it back.

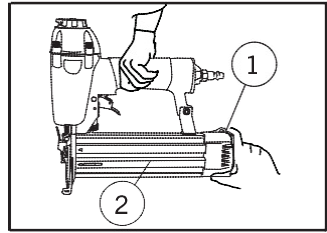

3. Insert a strip of nails (1) into the magazine. After ensuring that the points of the nails are facing down, close the magazine.

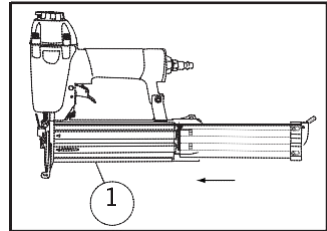

4. Plug in compressor, turn it on, set the pressure regulator to 90 PSI, attach one end of the air hose to the compressor and the other end of the air hose (2) to the tool (1). Use plumber's tape to prevent air leaks.

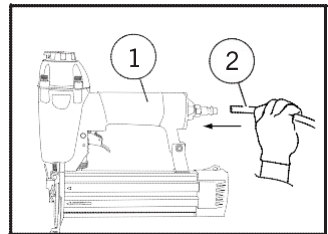

5. Test the driving depth of the tool against a sample piece of wood by pressing the trigger (1) before working on the workpiece.

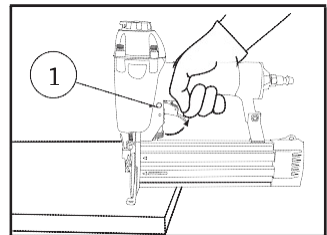

Fastener depth adjustment



WARNING!

- The safety tip must be in contact with the workpiece before activating the tool.
- Do not operate the tool if the nails are not loaded, as doing so may damage the tool.
- Do not fire nails into the air, as doing so may cause injury to the operators or others, apart from damaging the tool.
- Load the correct type of nails only. Failure to comply could lead to serious injury or loss of life.
- Disconnect the tool from the air supply line.

The Brad Nailer has a depth adjustment dial below the trigger to adjust the firing depth of the fasteners.

Note: Refer to the graphic imprinted below the trigger and adjust the firing depth accordingly.

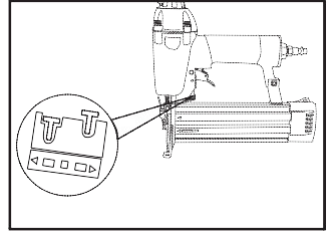

DECREASING FASTENER DEPTH

Turn the depth adjustment dial counterclockwise (with the discharge area of the tool facing away from the operator).

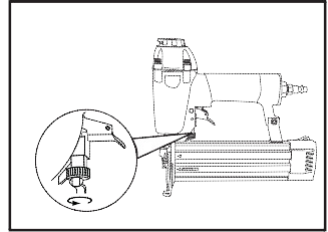

INCREASING FASTENER DEPTH

Turn the depth adjustment dial clockwise (with the discharge area of the tool facing away from the operator).

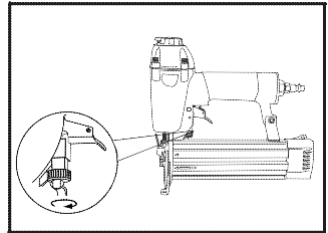

FIRING MODES

The Nailer has two firing modes: Single-Sequential actuation for single firing, or Contact / bump actuation for repetitive, fast firing of nails.

Each mode requires a different method of operation:

Single Firing: To operate the tool in this manner, first position the Workpiece Contact on the work surface, **WITHOUT PULLING THE TRIGGER**. Depress the Workpiece Contact until the Workpiece contact (nose of tool) touches the work surface and then pull the trigger to drive a fastener. Do not press the tool against the work with extra force. Instead allow the tool to recoil off the work surface to avoid a second, unwanted fastener. Remove your finger from the trigger.

Contact or Bumping actuation mechanism: To operate the tool in this manner, hold the tool with the Workpiece Contact pointing towards but not touching the work surface. Pull the trigger and then tap (bump) the Workpiece Contact against the work surface using a bouncing motion. Each depression of

the Workpiece Contact will cause a fastener to be driven.

 **WARNING** Extreme care should be taken because a nail will be driven when the firing head contacts any surface.

 **WARNING!** Never free-fire the tool at high pressure.

Clearing a jammed nail

- Remove the non-jammed nails that are stored in the tool's magazine.
- Operate the magazine latch and slide the pusher back to open the magazine for checking the jammed nails.
- Use pliers or any appropriate tool to remove the jammed nails.
If the nail is jammed in the "firing" location, pull the Quick Nail Extraction lever away from the tool to access and remove the jammed nail.
- Close the magazine cover and slide the pusher to its original position.
- Reload the nails into the tool magazine.
- Reconnect the air supply line to the tool's air inlet.
- Test fire 3 to 5 nails into a piece of scrap wood in order to ensure a proper operation.

Storage

- If it is necessary to store the tool for an extended period of time, apply a generous amount of lubrication before storing.
- The tool should be allowed to run for approximately 30 seconds after lubricating, in order to ensure that the lubrication is uniformly distributed throughout the tool.

Maintenance

NOTE: Do not store the tool anywhere temperatures will fall below freezing.



DANGER!

Disconnect the tool from the air compressor before maintenance/service, adjusting and when it is not in use.

Repairs must be performed by a qualified service technician only.

Failure to comply will lead to serious injury or loss of life.

MAINTENANCE REQUIRED	DESCRIPTION	TOOLS OR MATERIALS REQUIRED	MAXIMUM SERVICE INTERVAL		
			Each use or every 2 hrs.	Monthly	As needed
General inspection - free movement	Trigger, spring,	None	X		
In-depth inspection	Worn or broken parts			X	X
Replace worn or broken parts					X
Lubrication	See below	Pneumatic tool oil	X		

Lubrication: If the Air-powered brad nailer and the compressor are not equipped with an in-line lubrication system, place 2 to 3 drops of pneumatic tool oil into the air inlet before each use or after every 2 hours of continuous use, depending on the characteristics of the workpiece and type of fasteners used.

- Inspect the trigger, spring, and the safety mechanism for free movement on a regular basis in order to ensure that the safety system is fully functional. Verify that no part is loose or missing and that no parts are sticking or jammed.
- Keep the magazine and the safety tip of the tool clean and free of any dirt or abrasive particles
- Air-operated tools must be inspected periodically, and worn or broken parts must be replaced in order to keep tools operating safely and efficiency.
- Inspect and replace worn or damaged O-rings, seals, etc. Tighten all screws and caps frequently in order to help prevent personal injury.

Troubleshooting



DANGER!

If any of the following symptoms appear while the tool is in use, turn it off and disconnect it from the air supply immediately. Failure to comply will lead to serious injury or loss of life. Disconnect the tool from the air supply before making any adjustments. Repairs must be performed by a qualified service technician only.

The following chart lists common issues and solutions. Please read it carefully and follow all instructions carefully.

Problem	Possible causes	Solutions
Air leakage at the top of the tool or in the trigger area.	<ol style="list-style-type: none"> 1. O-rings in the trigger valve are damaged. 2. The trigger valve heads are damaged. 3. Trigger valve stem, seal, or O-rings are damaged. 	<ol style="list-style-type: none"> 1. Inspect and replace the O-ring. 2. Inspect and replace trigger valve heads. 3. Inspect and replace the trigger valve stem, seal, or O-ring
Air leakage near the bottom of the tool.	<ol style="list-style-type: none"> 1. The screws are loose. 2. The O-rings or the bumper is worn or damaged. 	<ol style="list-style-type: none"> 1. Tighten the screws. 2. Inspect and replace the O-rings or the bumper.
Air leakage between the bottom and the cylinder cap.	<ol style="list-style-type: none"> 1. The screws are loose. 2. The O-rings or the seals are worn or damaged. 	<ol style="list-style-type: none"> 1. Tighten the screws. 2. Inspect and replace the O-rings or the seals.

Problem	Possible causes	Solutions
<p>The nails are being driven too deep.</p>	<ol style="list-style-type: none"> 1. The bumper is worn. 2. The air pressure is too high. 3. The depth adjustment knob is not adjusted properly. 	<ol style="list-style-type: none"> 1. Replace the bumper. 2. Adjust the air pressure. 3. Adjust the depth setting by turning the depth adjustment knob counterclockwise (see section "Adjusting nail depth" for more detailed instructions).
<p>The tool does not operate properly - it does not drive the nails or operates sluggishly.</p>	<ol style="list-style-type: none"> 1. The air supply is inadequate. 2. Lubrication is inadequate. 3. The O-rings or seals are worn or damaged. 4. The exhaust deflector in the cylinder head is blocked. 	<ol style="list-style-type: none"> 1. Verify that the air supply is adequate. 2. Pour up to 6 drops of oil into the air inlet. 3. Inspect and replace O-rings or seals. 4. Replace the damaged internal parts.
<p>The tool skips nails.</p>	<ol style="list-style-type: none"> 1. The bumper is worn, or the spring is damaged. 2. There is dirt in the front plate. 3. Nails cannot move freely in the magazine due to dirt or wear. 4. The O-ring on the piston is worn or dry or lubrication is insufficient. 5. The cylinder cover seal is leaking. 	<ol style="list-style-type: none"> 1. Replace the bumper or spring. 2. Clean the drive channel on the front plate. 3. Clean the magazine. 4. Replace the O-ring. 5. Replace the sealing washer.

<p>The tool jams.</p>	<ol style="list-style-type: none">1. Improper nails are used, or nails are damaged.2. The driver guide is damaged or worn.3. The magazine screw is loose.4. There is dirt in magazine.	<ol style="list-style-type: none">1. Use proper nails. (See section "Clearing a jammed nail.")2. Inspect and replace the driver.3. Tighten the magazine.4. Open and clean the magazine.
-----------------------	---	--

EXPLODED VIEW

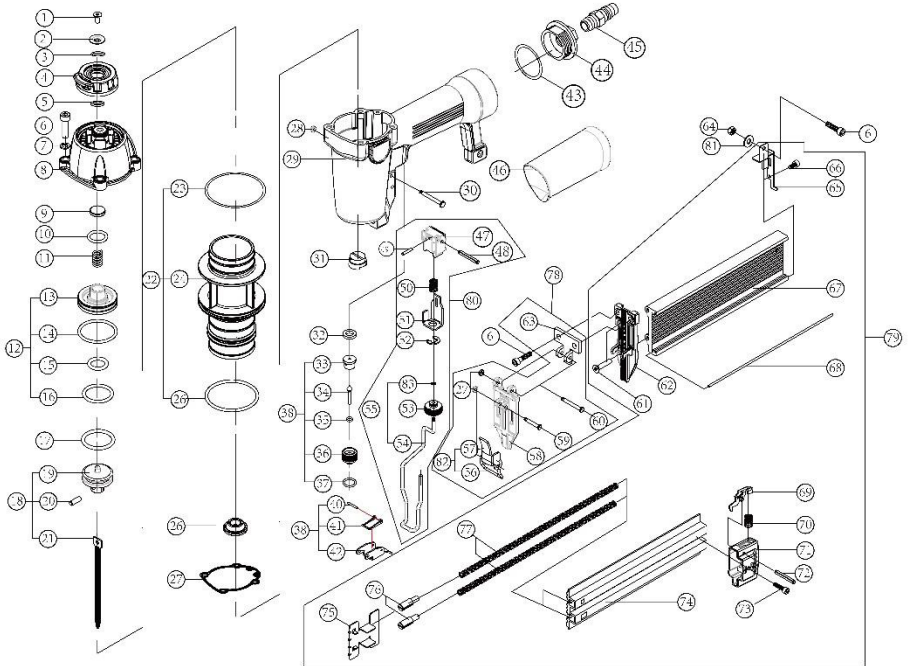

PARTS LIST

⚠ WARNING When servicing, use only original equipment replacement parts. The use of any other parts may create a safety hazard or cause damage to the tool. Any attempt to repair or replace electrical parts on this tool may create a safety hazard unless repairs are performed by a qualified technician. For more information, call the Toll-free Helpline, at 1-866-349-8665.

Always order by PART NUMBER, not by key number.

Key#	Part #	Part Name	Qty
1	1282-201-001	SCREW 4*6	1
2	1282-201-002	WASHER	1
3	1282-201-003	O-RING 16*1.7	1
4	1282-201-004	EXHAUST COVER	1
5	1282-201-005	O-RING 14*1.8	1
6	1282-201-006	SCREW 5*20	7
7	1282-201-007	WASHER #5	4
8	1282-201-008	Cylinder CAP	1
9	1282-201-009	SEAL, AIR	1
10	1282-201-010	O-RING 13.8*2.4	1
11	1282-201-011	FEEDER SPRING	1
12	1282-201-012	HEAD VALVE PISTON SET	1
13	1282-201-013	FIRING VALVE PISTON	1
14	1282-201-014	O-RING 36.3*2.55	1
15	1282-201-015	O-RING 13*3	1
16	1282-201-016	O-RING 24.5*3	1
17	1282-201-017	O-RING 22.9*2.7	1
18	1282-201-018	PISTON SET	1
19	1282-201-019	Piston head	1
20	1282-201-020	PIN (4.2*13.5)	1
21	1282-201-021	DRIVER BLADE	1
22	1282-201-022	CYLINDER SET	1
23	1282-201-023	O-RING 43.7*2.65	1
24	1282-201-024	CYLINDER	1
25	1282-201-025	O-RING 31.5*2.65	1
26	1282-201-026	BUMPER	1
27	1282-201-027	GASKET	1
28	1282-201-028	RING 5.5*2	3
29	1282-201-029	Body	1
30	1282-201-030	PIN	1

Key#	Part #	Part Name	Qty
31	1282-201-031	NOZZLE	1
32	1282-201-032	SEAL, AIR T=2.5	1
33	1282-201-033	Upper Housing	1
34	1282-201-034	Remote Core	1
35	1282-201-035	O-RING 3.5*1.5	1
36	1282-201-036	Trigger Valve Guide	1
37	1282-201-037	O-RING 11*1.9	1
38	1282-201-038	TRIGGER VALVE SET	1
39	1282-201-039	TRIGGER SET	1
40	1282-201-040	SPRING PIN 2*15	1
41	1282-201-041	RELEASING BLADE	1
42	1282-201-042	TRIGGER	1
43	1282-201-043	O-RING 37.5*3.55	1
44	1282-201-044	Tail Cover	1
45	1282-201-045	AIR PLUG	1
46	1282-201-046	HANDLE GRIP	1
47	1282-201-047	FLAKE	1
48	1282-201-048	SPRING PIN 3*24	1
49	1282-201-049	SPRING PIN 2*12	1
50	1282-201-050	FEEDER SPRING	1
51	1282-201-051	RELEASE CATCH	1
52	1282-201-052	E-RING #6 T=0.8	1
53	1282-201-053	Screw	1
54	1282-201-054	RELEASE CATCH	1
55	1282-201-055	CATCH RELEASE SET	1
56	1282-201-056	RETAINER SPRING	1
57	1282-201-057	Click lever set	1
58	1282-201-058	DRIVER GUIDE COVER	1
59	1282-201-059	PIN	1
60	1282-201-060	PIN	1
61	1282-201-061	SCREW M4*18	2
62	1282-201-062	DRIVER GUIDE	1
63	1282-201-063	Spacer	1
64	1282-201-064	NUT M5	1
65	1282-201-065	SCREW 4*12	1
66	1282-201-066	Magazine Support	1

Key#	Part #	Part Name	Qty
67	1282-201-067	LOWER MAG.	1
68	1282-201-068	Steel Bar Ø2.16*160	1
69	1282-201-069	CLICK LEVER	1
70	1282-201-070	TORSION SPRING	1
71	1282-201-071	Tail Cover	1
72	1282-201-072	SPRING PIN 3*14	1
73	1282-201-073	SCREW M4*16	1
74	1282-201-074	UPPER MAG	1
75	1282-201-075	Pusher	1
76	1282-201-076	Magazine Support	2
77	1282-201-077	FEEDER SPRING	2
78	1282-201-078	DRIVER GUIDE COVER SET	1
79	1282-201-079	MAGAZINE SET	1
80	1282-201-080	CATCH RELEASE SET	1
81	1282-201-081	WASHER	1
82	1282-201-082	CLICK LEVER SET	1
83	1282-201-083	WASHER 3.5	1

WARRANTY

RADLEY WARRANTY

If this Radley tool fails due to a defect in material or workmanship within three years from the date of purchase, return it to any Home Hardware store with the original bill of sale for exchange. Two years for battery and charger. This warranty does not include expendable parts including but not limited to blades, brushes, belts and light bulbs. This warranty covers defects in material or workmanship only. It does not cover normal wear and tear, failure due to abuse/misuse, or defects caused by careless or accidental mishandling. If this Radley product is used for commercial or rental purposes, this warranty does not apply.

18 GAUGE PNEUMATIC BRAD NAILER

OWNER'S MANUAL



3 Year Limited Warranty on tool

Radley®

RADLEY TOOLS
ST. JACOBS, ONTARIO N0B 2N0
© 2021 Home Hardware Store's
Limited
1-866-349-8665
Customer Service/Tech Support

1282-201

Made in China

**3 Year
warranty**

This Radley® product carries a three (3) year LIMITED warranty against defects in workmanship and materials. See Owner's Manual for full details.

**READ ALL INSTRUCTIONS BEFORE FIRST USE.
KEEP THIS MANUAL FOR FUTURE REFERENCE.
KEEP AWAY FROM CHILDREN.**



**WEAR CSA APPROVED
EYE PROTECTION**



**WEAR EAR
PROTECTION**



**WEAR FACE
PROTECTION**