

BENCHMARK™ MC

20V MAX VARIABLE SPEED RECIPROCATING SAW



5 Year Limited Warranty on tool
battery and charger not included



JD522020

**READ ALL INSTRUCTIONS BEFORE FIRST USE.
KEEP THIS MANUAL FOR FUTURE REFERENCE.
KEEP AWAY FROM CHILDREN.**

Maximum initial battery voltage (measured without a load)
is 20 volts. Normal voltage is 18 volts.



**WEAR CSA APPROVED
EYE PROTECTION**



**WEAR EAR
PROTECTION**



**WEAR A
FACE MASK**

PRODUCT SPECIFICATIONS

20V MAX VARIABLE SPEED RECIPROCATING SAW	
Voltage	20V MAX*
Variable Speed	0-3,000 SPM
Length of Stroke	1" (25.4 mm)
Max. Cutting Capacity - Wood	(w/12" blade) 3-1/8" (80 mm)
Max. Cutting Capacity - Pipe	3/4" (20 mm)
Max. Cutting Capacity - Steel	3/8" (10 mm)
Electric Brake	Yes
Batteries (Sold Separately)	5350-023 (2.5Ah), 5350-011 (4Ah), 5350-012 (5Ah)
Charger (Sold Separately)	5350-010 2.4Amp 5350-022 6 A Fast Charger
Tool Weight	3.7Lb (1.67Kg) Tool Only

NEED ASSISTANCE?

Call our toll-free customer support line:

1-866-349-8665 (Monday through Friday 9am – 5pm Eastern Standard Time)

- Technical questions
- Replacement parts
- Parts missing from package











TABLE OF CONTENTS

Product Specifications.....	1
Table of Contents.....	2
General Safety Warnings.....	3
Specific Reciprocating Saw Safety.....	6
Safety Symbols.....	7
Know your 20v Max VS Reciprocating Saw.....	8
Operation and Assembly.....	9
Maintenance.....	14
Exploded View.....	16
Parts List.....	17
Warranty.....	18

GENERAL SAFETY WARNINGS

WARNING:

Before using this tool or any of its accessories, read this manual and follow all Safety Rules and Operating Instructions. The important precautions, safeguards and instructions appearing in this manual are not meant to cover all possible situations. It must be understood that common sense and caution are factors which cannot be built into the product.

SYMBOL	MEANING
<p> DANGER</p>  	<p>ALWAYS WEAR EYE PROTECTION THAT CONFORMS WITH CSA Z94.3 or ANSI SAFETY STANDARD Z87.1</p> <p>FLYING DEBRIS can cause permanent eye damage. Prescription eyeglasses ARE NOT a replacement for proper eye protection.</p> <p>Non-compliant eyewear can cause serious injury if broken during the operation of a power tool.</p>
<p> WARNING</p> 	<p>Use hearing protection, particularly during extended periods of operation of the tool, or if the operation is noisy.</p>
<p> WARNING</p> 	<p>WEAR A DUST MASK THAT IS DESIGNED TO BE USED WHEN OPERATING A POWER TOOL IN A DUSTY ENVIRONMENT.</p> <p>Dust that is created by power sanding, sawing, grinding, drilling, and other construction activities may contain chemicals that are known to cause cancer, birth defects, or other genetic abnormalities.</p> <p>These chemicals include:</p> <ul style="list-style-type: none"> • Lead from lead-based paints • Crystalline silica from bricks, cement, and other masonry products • Arsenic and chromium from chemically treated lumber. <p>The level of risk from exposure to these chemicals varies, according to how often this type of work is performed. In order to reduce exposure to these chemicals, work in a well-ventilated area, and use approved safety equipment, such as a dust mask that is specifically designed to filter out microscopic particles.</p>
<p> WARNING</p> 	<p>To avoid electrical hazards, fire hazards or damage to the tool, use proper circuit protection.</p> <p>This tool is wired at the factory for 120 Volts AC operation. It must be connected to a 120 Volts AC, 15 Amps circuit that is protected by a time-delayed fuse or circuit breaker. To avoid shock or fire, replace power cord immediately if it is worn, cut or damaged in any way.</p>
<p> WARNING</p> 	<p>Ventilation openings in batteries and chargers must always be open to allow cooling air to circulate freely. Air vents that are blocked, restricted or covered may result in the battery or charger overheating. Overheating may lead to damage to the tool or cause a fire, resulting in possible serious injury.</p>

POWER TOOL SAFETY WARNING

 **WARNING:** Read all safety warnings and all instructions. Failure to follow the warnings and instructions may result in electric shock, fire and/or serious injury.

Save all warnings and instructions for future reference.

WORK AREA SAFETY

Keep work area clean and well lit. Cluttered or dark areas invite accidents.

Do not operate power tools in explosive atmospheres, such as in the presence of flammable liquids, gases or dust. Power tools create sparks which may ignite the dust or fumes.

Keep children and bystanders away while operating a power tool. Distractions can cause you to lose control.

ELECTRICAL SAFETY

Power tool plugs must match the outlet. Never modify the plug in any way.

Do not use any adapter plugs with earthed (grounded) power tools. Unmodified plugs and matching outlets will reduce risk of electric shock.

Avoid body contact with earthed or grounded surfaces such as pipes, radiators, ranges and refrigerators. There is an increased risk of electric shock if your body is earthed or grounded.

Do not expose power tools to rain or wet conditions. Water entering a power tool will increase the risk of electric shock.

Do not abuse the cord. Never use the cord for carrying, pulling or unplugging the power tool. Keep cord away from heat, oil, sharp edges or moving parts.

Damaged or entangled cords increase the risk of electric shock.

When operating a power tool outdoors, use an extension cord suitable for outdoor use. Use of a cord suitable for outdoor use reduces the risk of electric shock.

If operating a power tool in a damp location is unavoidable, use a residual current device (RCD) protected supply. Use of a ground fault circuit interrupter (GFCI) protected supply. Use of a ground fault circuit interrupter (GFCI) reduces the risk of electric shock.

PERSONAL SAFETY

Stay alert, watch what you are doing and use common sense when operating a power tool. Do not use a power tool while you are tired or under the influence of drugs, alcohol, or medication. A moment of inattention while operating power tools may result in serious personal injury.

Use personal protective equipment. Always wear eye protection. Protective equipment such as dust mask, non-skid safety shoes, hard hat, or hearing protection used for appropriate conditions will reduce personal injuries.

Prevent unintentional starting. Ensure the switch is in the off-position before connecting to power source and/or battery pack, picking up or carrying the tool. Carrying power tools with your finger on the switch or energizing power tools that have the switch on invites accidents.

Do not overreach. Keep proper footing and balance at all times. This enables better control of the power tool in unexpected situations.

Dress properly. Do not wear loose clothing or jewellery. Keep your hair, clothing, and gloves away from moving parts. Loose clothes, jewellery or long hair can be caught in moving parts.

If devices are provided for the connection of dust extraction and collection facilities, ensure these are connected and properly used. Use of dust collection can reduce dust-related hazards.

POWER TOOL USE AND CARE

DO NOT force the power tool. Use the correct power tool for your application. The correct power tool will do the job better and safer at the rate for which it was designed. **DO NOT** use the power tool if the switch does not turn it on and off. Any power tool that cannot be controlled with the switch is dangerous and must be repaired.

Disconnect the plug from the power source and/or the battery pack from the power tool before making any adjustments, changing accessories, or storing power tools. Such preventive safety measures reduce the risk of starting the power tool accidentally.

Store idle power tools out of the reach of children and **DO NOT** allow persons unfamiliar with the power tool or these instructions to operate the power tool. Power tools are dangerous in the hands of untrained users.

Maintain power tools. Check for misalignment or binding of moving parts, breakage of parts and any other condition that may affect the power tool's operation. If damaged, have the power tool repaired before use. Many accidents are caused by poorly maintained power tools.

Keep cutting tools sharp and clean. Properly maintained cutting tools with sharp cutting edges are less likely to bind and are easier to control.

Use the power tool, accessories and tool bits, etc. in accordance with these instructions, taking into account the working conditions and the work to be performed. Use of the power tool for operations different from those intended could result in a hazardous situation.

Hold power tool by insulated gripping surfaces, when performing an operation where the fastener may contact hidden wiring or its own cord. Fasteners contacting a "live" wire may make exposed metal parts of the power tool "live" and could give the operator an electric shock.

Use clamps or other practical ways to secure and support the workpiece to a stable platform. Holding the workpiece by hand or against your body leaves it unstable and may lead to loss of control.

SERVICE

Have your power tool serviced by a qualified repair person using only identical replacement parts. This will ensure that the safety of the power tool is maintained.

BATTERY TOOL USE AND CARE

Recharge only with the charger specified by the manufacturer. A charger that is suitable for one type of battery pack may create a risk of fire when used with another battery pack.

Use power tools only with specifically designated battery packs.

Use of any other battery packs may create a risk of injury and fire.

When battery pack is not in use, keep it away from other metal objects, like paper clips, coins, keys, nails, screws, or other small metal objects that can make a connection from one terminal to another. Shorting the battery terminals together may cause burns or a fire.

Under abusive conditions, liquid may be ejected from the battery; avoid contact. If contact accidentally occurs, flush with water. If liquid contacts eyes, additionally seek medical help. Liquid ejected from the battery may cause irritation or burns.

SPECIFIC SAFETY INSTRUCTIONS FOR 20V RECIPROCATING SAW

⚠️ WARNING: Know your reciprocating saw. DO NOT plug in the charger or install the battery in the tool until you have read and understand this Instruction Manual. Learn the tool's applications and limitations, as well as the specific potential hazards related to this tool. Following this rule will reduce the risk of electric shock, fire, or serious injury.

Always keep hands out of the path of the saw blade. Avoid awkward hand positions where a sudden slip could cause your hand to move into the path of the saw blade.

⚠️ DANGER: Keep hands away from cutting area and the blade. Keep your second hand on the tool. If both hands are holding the saw, they cannot be cut by the blade.

Do not reach underneath the workpiece.



















Always wear eye protection. Any power tool can throw foreign objects into your eyes and cause permanent eye damage. ALWAYS wear safety goggles (not glasses) that comply with ANSI safety standard Z87.1. Everyday glasses have only impact resistant lenses. They ARE NOT safety glasses.

⚠️ WARNING: Glasses or goggles not in compliance with ANSI Z87.1 could cause serious injury when they break.

SYMBOLS

⚠ WARNING: Some of the following symbols may appear on the reciprocating saw. Study these symbols and learn their meaning. Proper interpretation of these symbols will allow for more efficient and safer operation of this too

V	Volts		Three-phase alternating current with neutral
A	Amperes		Direct current
Hz	Hertz		No load speed
W	Watts		Alternating or direct current
kW	Kilowatts		Class II Construction
μF	Microfarads		Splash-proof construction
L	Litres		Watertight construction
kg	Kilograms		Protective grounding at grounding terminal, Class I tools
H	Hours		Revolutions or reciprocations per minute
N/cm ²	Newtons per square centimetre		Diameter
Pa	Pascals		Off position
OPM	Oscillation per minute		Directional Arrow
Min	Minutes		Warning symbol
S	Seconds		Wear your safety glasses
~ or AC	Alternating current		Wear hearing protection
3 ~	Three-phase alternating current		Wear dust mask



This symbol designates that this tool is listed with U.S. and Canadian requirements by cTUVus Testing Laboratories, Inc.
 UL62841-1, UL62841-2-11;
 CSA C22.2#UL62841-1, UL62841-2-11.

KNOW YOUR 20V MAX VS RECIPROCATATION SAW

Tool Free
blade release

Pivoting Shoe

Tool-less
Adjustable shoe

Trigger Lock-off switch

VS trigger

Battery (sold separately)

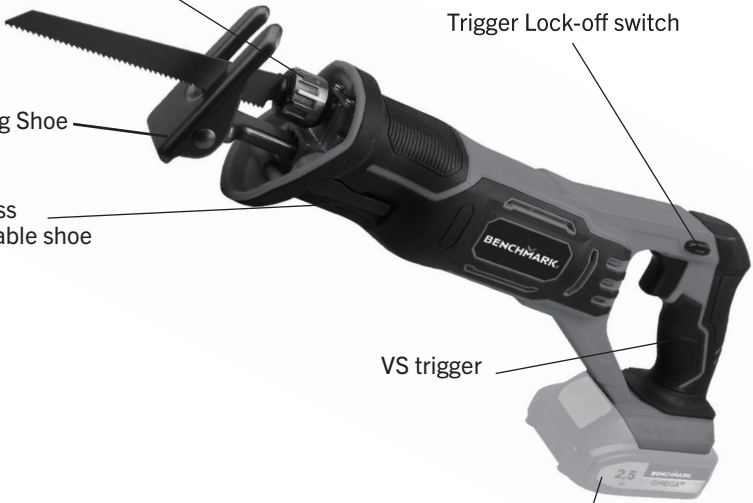

OPERATION AND ASSEMBLY

 **WARNING:** Always use hearing protection when sawing, particularly during extended periods of operation.

 **WARNING:** Always remove the battery before changing the blade and when making any adjustments.

DO NOT wear gloves, neckties or loose clothing.

Hold the tool by its insulated gripping surfaces when performing an operation where the saw blade may contact hidden wiring or its own cord. Contact with a "live" wire will make exposed metal parts of the tool "live" and shock the operator.

Always hold the tool with two hands. Attempting to control the tool with only one hand is dangerous. It could result in loss of control and serious injury.

Never hold the workpiece in one hand and the tool the other hand when sawing. Never place the hands near or below the cutting surface. Clamp the workpiece and guide the tool with both hands.

Always make sure the work surface is free from nails and other foreign objects. Cutting into a nail can cause the blade and the tool to jump and damage the blade.

Never lay the workpiece on hard surfaces like concrete, stone etc. The protruding blade may cause tool to jump.

After changing a blade or making adjustments, make sure the blade clamp is holding the blade securely. Loose blades could be violently thrown from the tool.

Never use dull or damaged blades. Sharp blades must be handled with care. Damaged blades can snap during use. Dull blades require more force to cut the workpiece, possibly causing the blade to break.

Never touch the blade during or immediately after use. After use, the blade is too hot to be touched.

IMPORTANT SAFETY INSTRUCTIONS

The warnings, precautions, and instructions discussed in this manual cannot cover all possible conditions and situations that may occur. The operator must understand that common sense and caution are factors which cannot be built into this product, but must be supplied by the operator.

 **WARNING:** Use only attachments recommended or sold by manufacturer.

1. **DO NOT** disassemble the saw. Take it to a qualified professional when service or repair is required. Incorrect reassembly may result in electric shock or fire.
2. Wear approved safety eye/face shield, ear defenders and hand protection.

DISPOSAL

At the end of the useful life of the Tools by Benchmark 20V MAX* Li-ion Reciprocating Saw, dispose of the components according to all state, federal and local regulations.

PURPOSE

20V Max* Li-ion Reciprocating Saw is ideal for demolition and remodeling. Designed to cut through many types of materials such as wood, metal, PVC and nails.

Always wear safety goggles and gloves.

⚠️WARNING: DO NOT immerse the battery pack in water. Sudden cooling could cause a hot battery to explode or leak.

INSTALLING A BLADE

⚠️WARNING: Always remove the battery from the tool before installing or removing a blade or adjusting the saw in any way.

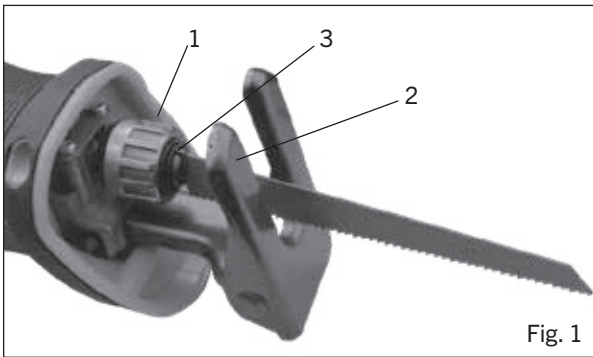

Fig. 1

1. To install a blade in the saw, rotate the blade locking sleeve (1) counter-clockwise (Fig. 1).
2. Insert the appropriate blade (2) into the blade slot (3) as far as it will go.
3. Release the blade locking sleeve.

NOTE: The blade will automatically be locked into the blade holder. Pull outward on the blade to ensure it is properly locked into the blade holder.

REMOVING A BLADE

To remove a blade, simply rotate the blade locking sleeve counter clockwise and remove the blade from the blade holder.

ADJUSTING THE PIVOTING SHOE

1. The pivoting shoe will pivot to follow the angle of the blade to the workpiece. This action ensures the flat surface of the shoe is against the workpiece for better cutting action and easier control of the saw.
2. The shoe can be adjusted in or out, allowing the use of the blade teeth at different points on the blade. This will provide longer blade life as one section of the blade becomes dull.
3. To adjust the pivoting shoe, rotate the pivoting shoe adjusting lever to its downward position.
4. Slide the pivoting shoe in or out until it is in the appropriate position.
5. Lock the pivoting shoe in place by rotating the pivoting shoe adjusting lever upward to its original horizontal position.

LOCK-OUT SWITCH

1. The lock-out switch (1) is a safety device designed to reduce the possibility of a user accidentally starting the saw. (Figure 2)
2. This switch must be pressed before the trigger (2) switch can be squeezed.

NOTE: The lock-out switch can be pressed from either the left or right side of the handle.

VARIABLE SPEED TRIGGER SWITCH

The trigger switch turns the reciprocating saw ON and OFF as well as controlling the speed.

1. To turn the saw ON, press the lock-out switch with your thumb. (Figure 2)
2. While holding the lock-out switch in the pressed position, squeeze the trigger (2) switch to start the saw. (Fig.3)
3. Once the saw starts, release the lock-out switch. The saw will remain running until the trigger switch is released.

NOTE: The trigger switch also controls the speed at which the saw runs. The more you squeeze the trigger, the faster the saw will run.

4. To turn the saw OFF, release the trigger switch.

NOTE: To re-start the saw, the lock-out switch must be pressed again before the trigger switch is squeezed.

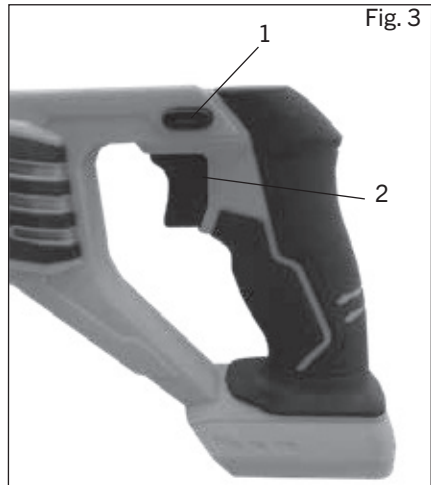
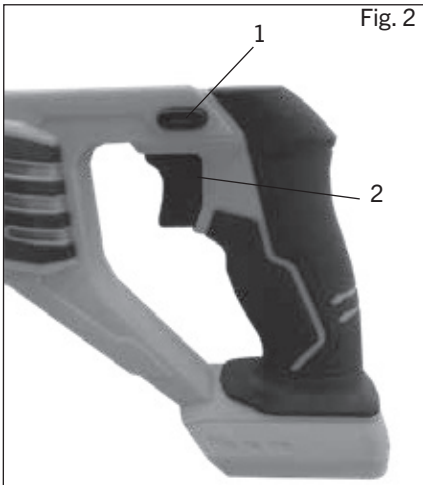

MATERIALS YOU CAN CUT

This reciprocating saw is a versatile tool that allows you to cut many different types of materials. Some of these materials include:

- Wood products such as lumber, hardwood, plywood, composite board, and paneling

NOTE: There are many different types of blades available. Generally, there are metal cutting blades (fine teeth) and wood cutting blades (coarse teeth). Use the correct blade for your application. The packaging on the blade will indicate the type of materials each blade is designed to cut.

GENERAL CUTTING

1. Clearly mark the workpiece to locate the position of the cut.
2. Hold smaller workpieces with a vice. Clamp larger workpieces to a workbench or table.

 **WARNING:** Any workpiece that is not adequately clamped in place may come loose and cause serious injury. Never hold the workpiece with your hand.

3. Make sure there are no nails, screws, clamps or foreign materials in
4. Hold the saw away from your body and in front of you.
5. With both hands firmly gripping the saw, and with the blade NOT in contact with the surface to be cut, start the saw by pressing the lock-out switch and squeezing the trigger switch.
6. Once the saw has reached the desired speed, place the adjustable pivoting shoe against the workpiece and gradually bring the moving blade into contact with the workpiece at the appropriate location.

CAUTION

DO NOT force the saw. Use only enough force to keep the blade cutting. Excessive pressure on the blade will cause it to bend and twist, which may result in breaking the blade.

PLUNGE CUTTING

1. Clearly mark the workpiece to locate the position of the cut.
2. Clamp the workpiece to a workbench or table.

NOTE: Make sure the area to be cut is clear under the workpiece so that the blade will not come into contact with anything other than the workpiece.

3. Select a convenient starting point in the area to be cut out. Place the tip of the blade over that point.
4. Rest the lower edge of the adjustable pivoting shoe on the workpiece and hold it firmly in that position, maintaining a shallow cutting angle.
5. Press the lock-out switch and squeeze the trigger switch to start the saw.

 **WARNING:** Make sure the blade does not touch the workpiece until the saw reaches full speed. Loss of control and possible injury could result.

6. With the saw running at full speed, slowly tilt the saw until the tip of the blade contacts the workpiece and begins to cut. After the blade cuts through the workpiece, tilt the saw upward until the blade is perpendicular to the workpiece.

METAL CUTTING

1. Metals such as pipe, steel rods, sheet steel, aluminum, brass and copper can be cut with your reciprocating saw.
2. To cut thin sheet material, "sandwich" the material between hardboard or plywood and clamp the layers to limit vibration and material tearing.
3. Always use a fine toothed metal cutting blade and run the saw at medium speeds when cutting metal.
4. Use cutting oil to keep the blade cool, increase cutting **DO NOT** twist or bend the saw blade.
5. **DO NOT** force the saw blade. Let it cut at its own speed.

 **WARNING:** Always clamp the workpiece in a vice, or to a workbench or table. **DO NOT** hold workpiece in your hand. Never use gasoline as a lubricant or as a cleaning agent. A spark from the motor may cause an explosion. Gasoline will also damage the plastic components of the saw.

MAINTENANCE

 **WARNING:** When servicing, use only identical replacement parts. The use of any other part may create a hazard or cause product damage.

DO NOT use solvents when cleaning plastic parts. Plastics are susceptible to damage from various types of commercial solvents and may be damaged by their use. Use a clean cloth to remove dirt, dust, oil, grease, etc.

 **WARNING: DO NOT** allow brake fluids, gasoline, petroleum-based products, penetrating oils, etc. to come into contact with plastic parts. They contain chemicals that can damage, weaken or destroy plastic.

DO NOT abuse power tools. Abusive practices can damage the tool and the workpiece.

 **WARNING: DO NOT** attempt to modify tools or create accessories. Any such alteration or modification is misuse and could result in a hazardous condition leading to possible serious injury. It will also void the warranty.

NOTE: It has been found that electric tools are subjected to accelerated wear and possible premature failure when they are used on fiberglass boats and sports cars, wallboard, spackling compounds or plaster. The chips and grindings from these materials are highly abrasive to electric tool parts such as bearings, brushes, commutators, etc. Consequently, it is not recommended that this tool be used for extended work on any fiberglass material, wallboard, spackling compounds or plaster. During any use on these materials, it is extremely important that the tool is cleaned frequently by blowing it out with an air jet.

LUBRICATION

All of the bearings in this tool are lubricated with a sufficient amount of high-grade lubricant for the life of the unit under normal conditions. Therefore, no further lubrication is required.

MAINTENANCE

⚠️ WARNING: When servicing, use only identical replacement parts. The use of any other part may create a hazard or cause product damage.

DO NOT use solvents when cleaning plastic parts. Plastics are susceptible to damage from various types of commercial solvents and may be damaged by their use. Use a clean cloth to remove dirt, dust, oil, grease, etc.

⚠️ WARNING: Do not allow brake fluids, gasoline, petroleum-based products, penetrating oils, etc. to come into contact with plastic parts. They contain chemicals that can damage, weaken or destroy plastic.

DO NOT abuse power tools. Abusive practices can damage the tool and the workpiece.

⚠️ WARNING: DO NOT attempt to modify tools or create accessories. Any such alteration or modification is misuse and could result in a hazardous condition leading to possible serious injury. It will also void the warranty.

Remove accumulated dust and debris regularly using a soft DRY brush.

It has been found that electric tools are subjected to accelerated wear and possible premature failure when they are used on fiberglass boats and sports cars, wallboard, spackling compounds or plaster. The chips and grindings from these materials are highly abrasive to electric tool parts such as bearings, brushes, commutators, etc. Consequently, it is not recommended that this tool be used for extended work on any fiberglass material, wallboard, spackling compounds or plaster. During any use on these materials it is extremely important that the tool is cleaned frequently by blowing it out with an air jet.

⚠️ WARNING: Always wear safety goggles or safety glasses with side shields during all sanding operations. It is critical that you also wear safety goggles or safety glasses with side shields and a dust mask while blowing dust out of the cut-out tool with an air jet. Failure to take these safety precautions could result in permanent eye or lung damage.

LUBRICATION

All of the bearings in this compact detail sander are lubricated with a sufficient amount of high grade lubricant for the life of the unit under normal conditions. Therefore, no further lubrication is required.

PARTS LIST

⚠ WARNING: When servicing, use only original equipment replacement parts. The use of any other parts may create a safety hazard or cause damage to the reciprocating saw .

Any attempt to repair or replace electrical parts on this reciprocating saw may create a safety hazard unless repairs are performed by a qualified technician. For more information, call the Toll-free Helpline, at 1-866-349-8665 Monday – Friday from 9am to 5pm Eastern Standard Time.

Always order by PART NUMBER, not by key number.

Key #	Part #	Part Name	Quantity
1	3010080021	Lock Off Switch	1
2	3120100053	Lever	1
3	2040290084	Insert	1
4	4020010167	Screw M4x12	4
5	2030160145	Gear Box Press Plate	1
6	2030160146	Big Gear Press Plate	1
7	2040310047	Shaft Coat	1
8	2010050041	Big Gear	1
9	2040050145	Shaft	1
10	2010080154	Shaft Coat	1
11	4010010043	Bearing 6000	1
12	3140060053	Front Anti-Vibration Bar	2
13	3140060053	Rear Anti-Vibration Bar	2
14	2050060218	Spring	1
15	3120040079	Lever	1
16	1030240006	Motor	1
17	2030160143	Plate	1
18	4020010186	Screw M5x10	2
19	4010010043	Bearing 6000	1
20	4100020012	Circlip 10	1
21	4010180063	Motor Gear	1
22	4010010022	Bearing 6900	1
23	2030020146	Washer	1
24	4020010161	Screw M5x12	1
25	4020010001	Screw M4x8	1
26	2050070065	Shrapnel	1
27	2030160147	Pressing Plate	1
28	4100020004	Circlip 6	1
29	2020010036	Gear Box	1

Key #	Part #	Part Name	Quantity
30	2010150059	Button Holder	1
31	3140050025	Oil Baffle	1
32	2010150055	Upper Holder	1
33	2030130043	Cover	1
34	4020010168	Screw M3x12	4
35	1150010043	Reciprocating Rod Assembly	1
36	2030100073	Bottom Support	1
37	1150020130	Plate	1
38	4030010106	Screw ST3.9x19	10
39	4030010074	Screw ST3.9x14	2
40	1060050027	Switch	1
41	4020010153	Screw M3x6	1
42	2020180023	Cooling Block	1
43	1180060030	Terminal Plate	1

WARRANTY

20V MAX VARIABLE SPEED RECIPROCATING SAW

If this Benchmark tool fails due to a defect in material or workmanship within five years from the date of purchase, return it to any Home Hardware store with the original bill of sale for exchange. 3-year warranty for the battery and charger. This warranty does not include expendable parts including but not limited to blades, brushes, belts, light bulbs.

This warranty covers defects in material or workmanship only. It does not cover normal wear and tear, failure due to abuse/misuse, or defects caused by careless or accidental mishandling. If this Benchmark product is used for commercial or rental purposes, this warranty does not apply.

20V MAX VARIABLE SPEED RECIPROCATING SAW



5 Year Limited Warranty on tool

BENCHMARKTM_{MC}

BENCHMARK TOOLS CANADA

ST. JACOBS, ONTARIO N0B 2N0

© 01 / 2021 Home Hardware Stores Limited

CUSTOMER SERVICE/TECH SUPPORT

1-866-349-8665

1270-204

Made in China



* This BenchmarkTM product carries a five (5) year LIMITED warranty against defects in workmanship and materials. The charger and batteries carry a three (3) year LIMITED warranty.



JD522020

**READ ALL INSTRUCTIONS BEFORE FIRST USE.
KEEP THIS MANUAL FOR FUTURE REFERENCE.
KEEP AWAY FROM CHILDREN.**

Maximum initial battery voltage (measured without a load)
is 20 volts. Normal voltage is 18 volts.



**WEAR CSA APPROVED
EYE PROTECTION**



**WEAR EAR
PROTECTION**



**WEAR A
FACE MASK**