

MASTERFORCE®

15 AMP CIRCULAR SAW

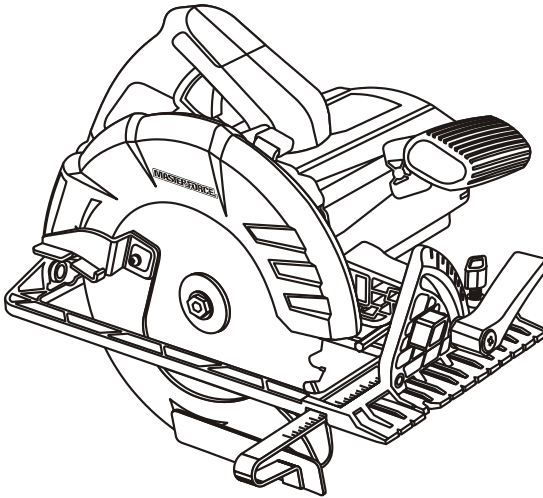

241-0741

For questions/comments, technical assistance or repair parts –
Please call toll free: 1-866-349-8665 (M–F 9am–5pm EST)

OPERATOR'S MANUAL

⚠ CAUTION: To Reduce The Risk Of Injury, User Must Read And Understand Operator's Manual. Save These Instructions For Future Reference.

TABLE OF CONTENTS

Front cover	1
Table of contents	2
General safety warnings	3–4
Eye, ear & lung protection	3–4
Electrical safety	4
Power tool safety	5–6
General safety rules	5
Work area safety	5
Electrical safety	5
Personal safety	5
Power tool use and care	6
Service	6
Specific safety rules	7–9
Causes and operator prevention of kickback	7–8
Additional specific safety rules	8–9
Product specifications	9
Symbols	10
Know your circular saw	11
Assembly and operating	12–17
Removing a blade	12
Setting the cutting depth	13
Setting the bevel cutting angle	13
Adjusting the 0° angle stop	13
Installing the rip guide	14
Live wire indicator	14
LED worklight	14
Trigger switch	15
Materials that you can cut	15
General cutting	15–16
Rip guide cutting	16
Plunge cutting	16–17
Maintenance	17
Exploded view	18
Parts list	19–20
Notes	21–22
Warranty	23
Back cover	24

GENERAL SAFETY WARNINGS



WARNING: Before using this tool or any of its accessories, read this manual and follow all Safety Rules and Operating Instructions. The important precautions, safeguards and instructions appearing in this manual are not meant to cover all possible situations. It must be understood that common sense and caution are factors which cannot be built into the product.

This instruction manual includes the following:

- General Safety Rules
- Specific Safety Rules and Symbols
- Functional Description
- Assembly
- Operation
- Maintenance
- Accessories

EYE, EAR & LUNG PROTECTION



ALWAYS WEAR EYE PROTECTION THAT CONFORMS WITH CSA REQUIREMENTS or ANSI SAFETY STANDARD Z87.1

FLYING DEBRIS can cause permanent eye damage. Prescription eyeglasses ARE NOT a replacement for proper eye protection.



WARNING: Non-compliant eyewear can cause serious injury if broken during the operation of a power tool.



WARNING: Use hearing protection, particularly during extended periods of operation of the tool, or if the operation is noisy.

SAVE THESE INSTRUCTIONS FOR REFERENCE

GENERAL SAFETY WARNINGS



WEAR A DUST MASK THAT IS DESIGNED TO BE USED WHEN OPERATING A POWER TOOL IN A DUSTY ENVIRONMENT.



WARNING: Dust that is created by power sanding, sawing, grinding, drilling, and other construction activities may contain chemicals that are known to cause cancer, birth defects, or other genetic abnormalities. These chemicals include:

Lead from lead-based paints

Crystalline silica from bricks, cement, and other masonry products

Arsenic and chromium from chemically treated lumber

The level of risk from exposure to these chemicals varies, according to how often this type of work is performed. In order to reduce exposure to these chemicals, work in a well-ventilated area, and use approved safety equipment, such as a dust mask that is specifically designed to filter out microscopic particles.

ELECTRICAL SAFETY



WARNING: To avoid electrical hazards, fire hazards or damage to the tool, use proper circuit protection.

This tool is wired at the factory for 120V AC operation. It must be connected to a 120V AC, 15 A circuit that is protected by a time-delayed fuse or circuit breaker. To avoid shock or fire, replace power cord immediately if it is worn, cut or damaged in any way.

SAVE THESE INSTRUCTIONS FOR REFERENCE

POWER TOOL SAFETY

▲ WARNING: Read all safety warnings and instructions. Failure to follow the warnings and instructions may result in electric shock, fire and/or serious injury.

Save all warnings and instructions for future reference.

Work area safety

Keep work area clean and well lit. Cluttered or dark areas invite accidents.

Do not operate power tools in explosive atmospheres, such as in the presence of flammable liquids, gases or dust. Power tools create sparks which may ignite the dust or fumes.

Keep children and bystanders away while operating a power tool. Distractions can cause you to lose control.

Electrical safety

Power tool plugs must match the outlet. Never modify the plug in any way. Do not use any adapter plugs with earthed (grounded) power tools. Unmodified plugs and matching outlets will reduce risk of electric shock.

Avoid body contact with earthed or grounded surfaces such as pipes, radiators, ranges and refrigerators. There is an increased risk of electric shock if your body is earthed or grounded.

Do not expose power tools to rain or wet conditions. Water entering a power tool will increase the risk of electric shock.

Do not abuse the cord. Never use the cord for carrying, pulling or unplugging the power tool. Keep cord away from heat, oil, sharp edges or moving parts. Damaged or entangled cords increase the risk of electric shock.

When operating a power tool outdoors, use an extension cord suitable for outdoor use. Use of a cord suitable for outdoor use reduces the risk of electric shock.

If operating a power tool in a damp location is unavoidable, use a residual current device (RCD) protected supply. Use of a ground fault circuit interrupter (GFCI) reduces the risk of electric shock.

Personal safety

Stay alert, watch what you are doing and use common sense when operating a power tool. Do not use a power tool while you are tired or under the influence of drugs, alcohol or medication. A moment of inattention while operating power tools may result in serious personal injury.

Use personal protective equipment. Always wear eye protection. Protective equipment such as dust mask, non-skid safety shoes, hard hat, or hearing protection used for appropriate conditions will reduce personal injuries.

Prevent unintentional starting. Ensure the switch is in the off-position before connecting to power source and/or battery pack, picking up or carrying the tool. Carrying power tools with your finger on the switch or energizing power tools that have the switch on invites accidents.

Remove any adjusting key or wrench before turning the power tool on. A wrench or a key left attached to a rotating part of the power tool may result in personal injury.

Do not overreach. Keep proper footing and balance at all times. This enables better control of the power tool in unexpected situations.

Dress properly. Do not wear loose clothing or jewelry. Keep your hair, clothing and gloves away from moving parts. Loose clothes, jewelry or long hair can be caught in moving parts.

If devices are provided for the connection of dust extraction and collection facilities, ensure these are connected and properly used. Use of dust collection can reduce dust-related hazards.

POWER TOOL SAFETY

Power tool use and care

Do not force the power tool. Use the correct power tool for your application. The correct power tool will do the job better and safer at the rate for which it was designed.

Do not use the power tool if the switch does not turn it on and off. Any power tool that cannot be controlled with the switch is dangerous and must be repaired.

Disconnect the plug from the power source and/or the battery pack from the power tool before making any adjustments, changing accessories, or storing power tools. Such preventive safety measures reduce the risk of starting the power tool accidentally.

Store idle power tools out of the reach of children and do not allow persons unfamiliar with the power tool or these instructions to operate the power tool. Power tools are dangerous in the hands of untrained users.

Maintain power tools. Check for misalignment or binding of moving parts, breakage of parts and any other condition that may affect the power tool's operation. If damaged, have the power tool repaired before use. Many accidents are caused by poorly maintained power tools.

Keep cutting tools sharp and clean. Properly maintained cutting tools with sharp cutting edges are less likely to bind and are easier to control.

Use the power tool, accessories and tool bits etc. in accordance with these instructions, taking into account the working conditions and the work to be performed. Use of the power tool for operations different from those intended could result in a hazardous situation.

Hold power tool by insulated gripping surfaces when performing an operation where the cutting tool may contact hidden wiring or its own cord. Contact with a "live" wire will make exposed metal parts of the tool "live" and shock the operator.

Use clamps or another practical way to secure and support the workpiece to a stable platform. Holding the work by hand or against your body leaves it unstable and may lead to loss of control.

Service

Have your power tool serviced by a qualified repair person using only identical replacement parts. This will ensure that the safety of the power tool is maintained.

SAVE THESE INSTRUCTIONS FOR REFERENCE

SPECIFIC SAFETY RULES

▲ WARNING: Know your circular saw. Do not plug the circular saw into the power source until you have read and understand this Instruction Manual. Learn the tool's applications and limitations, as well as the specific potential hazards related to this tool. Following this rule will reduce the risk of electric shock, fire, or serious injury.

Always wear eye protection. Any power tool can throw foreign objects into your eyes and cause permanent eye damage. ALWAYS wear safety goggles (not glasses) that comply with ANSI safety standard Z87.1. Everyday glasses have only impact resistant lenses. They ARE NOT safety glasses.



▲ WARNING: Glasses or goggles not in compliance with ANSI Z87.1 could cause serious injury when they break.

Always keep hands out of the path of the saw blade. Avoid awkward hand positions where a sudden slip could cause your hand to move into the path of the saw blade.

▲ DANGER: Keep hands away from cutting area and the blade. Keep your second hand on the tool. If both hands are holding the saw, they cannot be cut by the blade.

Do not reach underneath the workpiece. The guard cannot protect you from the blade below the workpiece.

Adjust the cutting depth according to the thickness of the workpiece. Less than a full tooth of the blade teeth should be visible below the workpiece or approximately 3/8" (10 mm).

Never hold piece being cut in your hands or across your leg. Secure the workpiece to a stable platform. It is important to support the work properly to minimize body exposure, blade binding, or loss of control.

Hold power tool by insulated gripping surfaces when performing an operation where the cutting tool may contact hidden wiring or its own cord. Contact with a "live" wire will also make exposed metal parts of the power tool "live" and shock the operator.

When ripping always use a straight edge guide. This improves the accuracy of cut and reduces the chance of the blade binding.

Always use blades with correct size and shape (diamond versus round) of arbor holes. Blades that do not match the mounting hardware of the saw will run eccentrically, causing loss of control.

Never use damaged or incorrect blade washers or bolt. The blade washers and bolt were specially designed for your saw, for optimum performance and safety of operation.

CAUSES AND OPERATOR PREVENTION OF KICKBACK

Kickback is a sudden reaction to a pinched, bound or misaligned saw blade, causing an uncontrolled saw to lift up and out of the workpiece toward the operator;

When the blade is pinched or bound tightly by the kerf closing down, the blade stalls and the motor reaction drives the unit rapidly back toward the operator.

If the blade becomes twisted or misaligned in the cut, the teeth at the back edge of the blade can dig into the top surface of the wood causing the blade to climb out of the kerf and jump back toward the operator.

Kickback is the result of saw misuse and/or incorrect operating procedures or conditions and can be avoided by taking proper precautions as given below:

Maintain a firm grip with both hands on the saw and position your arms to resist kickback forces. Position your body to the left or right side of the blade, but not in line with the blade. Kickback could cause the saw to jump backwards, but kickback forces can be controlled by the operator, if proper precautions are taken.

SPECIFIC SAFETY RULES

CAUSES AND OPERATOR PREVENTION OF KICKBACK – cont'd

When the blade is binding, or when interrupting a cut for any reason, release the trigger and hold the saw motionless in the material until the blade comes to a complete stop. Never attempt to remove the saw from the work or pull the saw backward while the blade is in motion or kickback may occur. Investigate and take corrective actions to eliminate the cause of blade binding.

When restarting a saw in the workpiece, center the saw blade in the kerf and check that saw teeth are not engaged into the material. If the saw blades are binding, it may walk up or kickback from the workpiece as the saw is restarted.

Support large panels to minimize the risk of blade pinching and kickback. Large panels tend to sag under their own weight. Supports must be placed under the panel on both sides, near the line of cut and near the edge of the panel.

Do not use dull or damaged blades. Unsharpened or improperly set blades produce narrow kerf causing excessive friction, blade binding and kickback.

ADDITIONAL SPECIFIC SAFETY RULES

Use extra caution when making a "plunge cut" into existing walls or other blind areas. The protruding blade may cut objects that can cause kickback.

Check the lower guard for proper closing before each use. Do not operate the saw if the lower guard does not move freely and close instantly. Never clamp or tie the lower guard into the open position. If the saw is accidentally dropped, the lower guard may be damaged. Raise the lower guard with the retracting handle and make sure it moves freely and does not touch the blade or any other part in all depths of cuts.

Check the operation of the lower guard spring. If the guard and the spring are not operating properly, they must be serviced before use. The lower guard may operate sluggishly due to damaged parts, gummy deposits, or a build-up of debris.

The lower guard should be retracted manually only for special cuts such as "plunge cuts" and "compound cuts". Raise lower guard by retracting handle and as soon as the blade enters the material, the lower guard must be released. For all other sawing, the lower guard should operate automatically.

Always observe that the lower guard is covering the blade before placing saw down on the bench or on the floor. An unprotected, coasting blade will cause the saw to walk backwards, cutting whatever is in its path. Be aware of the time it takes for the blade to stop after the switch is released.

Never operate the saw while it is being carried to another location. The blade guard may be open and potentially cause serious injury.

If the switch fails to turn the saw ON or OFF properly, stop using it immediately and have the saw switch repaired.

Always allow the saw to reach full speed before beginning the cut.

Never use the side of the blade for cutting. When making horizontal cuts, make sure the weight of the tool is not forcing the side of the blade to do the cutting. This will reduce the risk of kickback.

Make sure there are no nails or foreign objects in the area of the workpiece to be cut.

Never lay workpiece on hard surfaces like concrete, stone, etc. The protruding blade may cause tool to jump.

⚠ DANGER: To avoid injury from accidental starting, always remove the plug from the power source before making any adjustments and before installing or removing a saw blade.

SPECIFIC SAFETY RULES

*ADDITIONAL SPECIFIC SAFETY RULES –
cont'd*

When replacing the blade, make sure the replacement blade is 7 1/4" in diameter and is rated for 7,000 RPM. Installing an incorrect blade will result in possible injury and poor cutting action.

After changing a blade or making adjustments, make sure the blade clamp screw is securely tightened. Loose blades and adjustment devices will be violently thrown.

Never touch the blade during or immediately after use. After use the blade is too hot to be safely touched with bare hands.

PRODUCT SPECIFICATIONS

Rating:	120V, 60Hz AC
Amperes:	15 AMP
Blade speed:	5800 RPM (no load)
Arbor:	5/8"
Blade:	7 1/4", 5/8" arbor, 24 Tungsten carbide tipped teeth
Wood maximum cutting depth:	2 3/8" @ 90° 1 13/16" @ 45°
Bevel angle:	0–56° with positive stop at 45°
Weight:	9 lbs 8 oz

Need Assistance?



Call us on our toll free customer support line:
1-866-349-8665 Monday – Friday from 9am to 5pm
Eastern Standard Time











- Technical questions
- Replacement parts
- Parts missing from package

SAVE THESE INSTRUCTIONS FOR REFERENCE

SYMBOLS

▲ WARNING: Some of the following symbols may appear on the circular saw. Study these symbols and learn their meaning. Proper interpretation of these symbols will allow for more efficient and safer operation of this tool.

V	Volts
A	Amperes
Hz	Hertz
W	Watts
kW	Kilowatts
μF	Microfarads
L	Liters
kg	Kilograms
H	Hours
N/cm²	Newtons per square centimeter
Pa	Pascals
OPM	Oscillations per minute
Min	Minutes
S	Seconds
 or a.c.	Alternating current
	Three-phase alternating current
	Three-phase alternating current with neutral

	Direct current
n_o	No load speed
	Alternating or direct current
	Class II construction
	Splash-proof construction
	Watertight construction
	Protective grounding at grounding terminal, Class I tools
.../min	Revolutions or reciprocations per minute
∅	Diameter
0	Off position
	Arrow
	Warning symbol
	Wear your safety glasses
	Keep hands away from blade



This symbol designates that this tool is listed with U.S. requirements by Underwriters Laboratories. Conforms to UL Std. 60745-1 and 60745-2-5.

KNOW YOUR CIRCULAR SAW

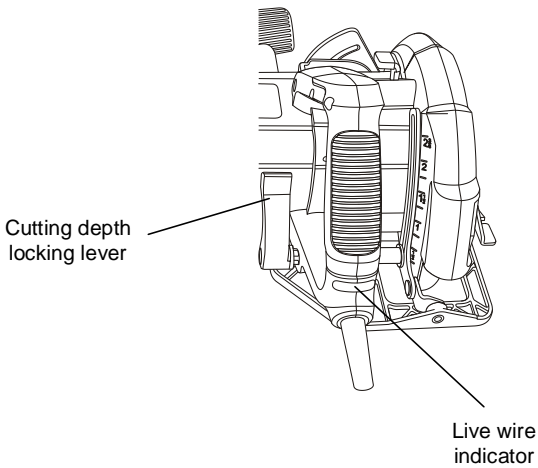
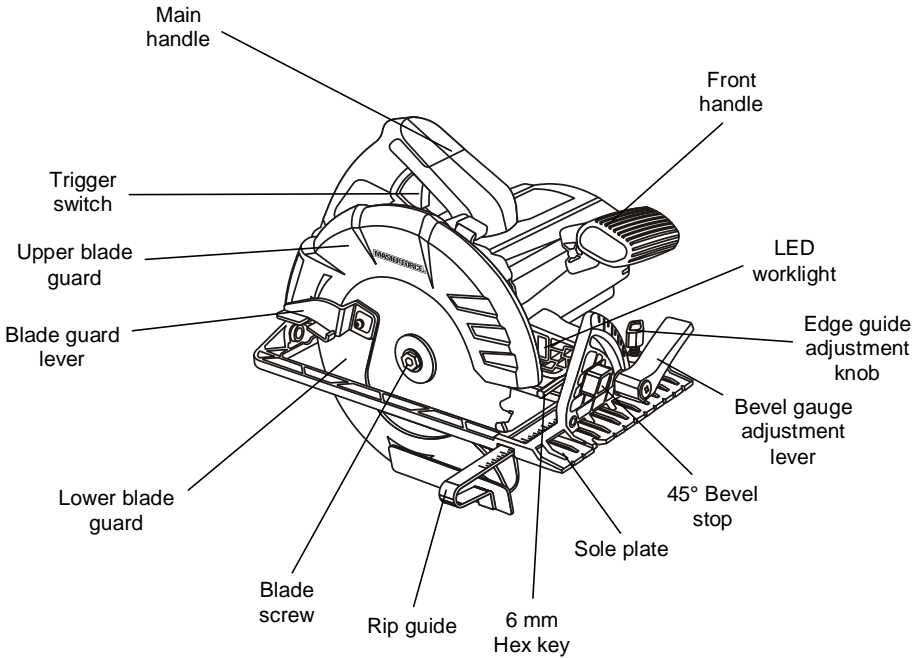

ASSEMBLY AND OPERATING

REMOVING A BLADE

⚠ WARNING: Always remove the plug from the power source before installing or removing a blade or adjusting the saw in any way.

1. Place a clean piece of cardboard on a workbench to protect the blade and the workbench.
2. Place the circular saw on the cardboard with the motor end DOWN. Positioning the tool in this position will make removal and replacement of the blade much easier.
3. Rotate the lower blade guard lever (1) clockwise toward the front of the saw and carefully place the saw on the corrugated with the blade teeth (2) resting on the cardboard (Fig. 1).

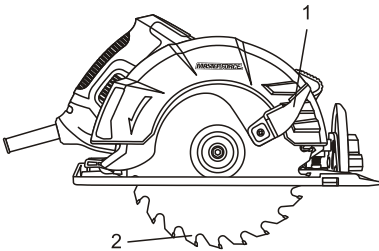

Fig. 1

4. Pressing on the blade locking lever (3) slowly rotate the blade until the locking lever engages the spindle (Fig. 2).

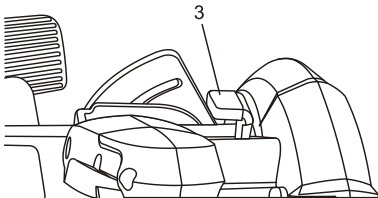

Fig. 2

5. Insert the 6 MM blade hex key into the blade screw (4) (Fig. 3).
6. Continue to press on the blade locking lever, rotate the blade screw wrench counter clockwise to loosen the blade screw.
7. Carefully remove the blade screw, outer blade flange (5) and the blade (6).

NOTE: Do NOT remove the inner blade flange (7) from the arbor (8). If it should fall off, make sure the THICKER boss on the washer is facing the motor.

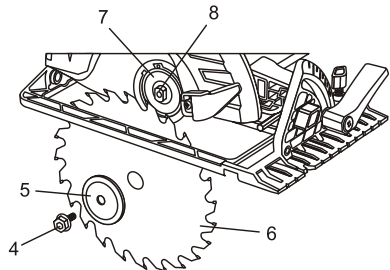

Fig. 3

To install a new blade, simply reverse the above blade removal procedure.

When installing a new blade, make sure you follow these precautions:

- a) Make sure the teeth at the bottom of the blade are pointing toward the front of the saw.
- b) Check the inner flange washer to make sure the thicker boss is pointing toward the motor.
- c) Place the outer flange washer so the flat surface is against the blade and the rectangular hole properly mated with the arbor.
- d) Make sure the flanged blade screw is NOT cross threaded and is fully tightened with the wrench provided.
- e) Before turning the saw ON, carefully rotate the blade by hand to make sure it does not wobble.

ASSEMBLY AND OPERATING

SETTING THE CUTTING DEPTH

The cutting depth of the blade should be set to suit the thickness of the material being cut. The cutting depth should be approximately 1/8" (3 mm) greater than the thickness of the material being cut.

1. Lift the depth adjustment locking lever (1) upward (Fig. 4).
2. Pull the sole plate (2) downward until the correct amount of the blade is protruding below the sole plate.

NOTE: The depth indicator (3) will identify the relative depth of cut on the scale (4).

3. Lock the sole plate at the correct depth by pushing the depth control locking lever downward.

NOTE: Make a test cut on a scrap workpiece to verify the depth setting.

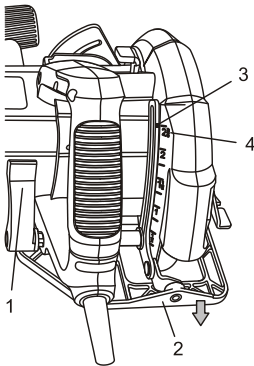

Fig. 4

SETTING THE BEVEL CUTTING ANGLE

The sole plate can be tilted to provide bevel cuts from 0°–56°.

1. Lift the bevel angle locking lever (1) upward (Fig. 5).
2. Rotate the sole plate (2) to the desired angle as shown on the bevel gauge (3).

3. Lock the sole plate at the correct angle by pushing the bevel angle locking lever downward.

NOTES:

- a) The bevel angle will automatically stop at 45°. To cut at bevel angles greater than 45°, press the 45° stop button (4) and continue to rotate the sole plate to the desired angle.
- b) Make a test cut on a scrap workpiece to verify the bevel angle setting.

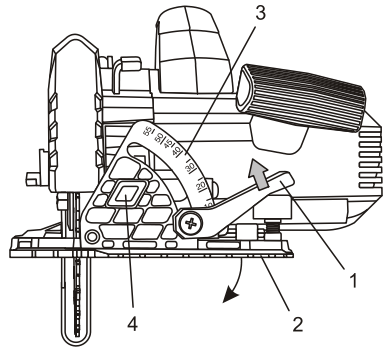

Fig. 5

ADJUSTING THE 0° ANGLE STOP

1. Set the bevel angle to 0° (1) (Fig. 6).
2. Use a carpenter's square to check the angle between the blade and the sole plate.
3. If the angle is NOT 90°, use a 2.5 mm hex key and adjust the 0° set screw (2) so the angle is 90° when the 0° stop contacts the set screw.

NOTE: Make a test cut to verify that the saw is cutting at 90°

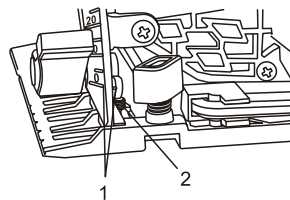

Fig. 6

ASSEMBLY AND OPERATING

INSTALLING THE RIP GUIDE

1. Loosen the rip guide adjusting knob (1) (Fig. 7).
2. Slide the rip guide rod (2) into the rip guide slot (3). Continue to slide the rip guide rod across the sole plate and into the rip guide slot under the rip guide adjusting knob.
3. Adjust the rip guide shoe to the correct distance from the blade and tighten the rip guide adjusting knob.

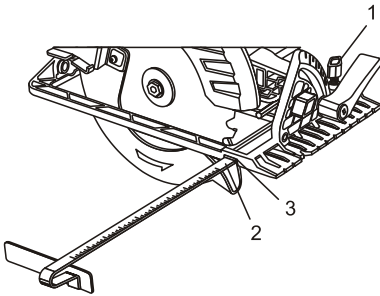

Fig. 7

LIVE WIRE INDICATOR

The live wire indicator (1) will turn ON when the plug is inserted into a "live" 110V receptacle (Fig. 8). If the live wire indicator fails to turn on, this indicates the plug is not inserted into a "live" receptacle.

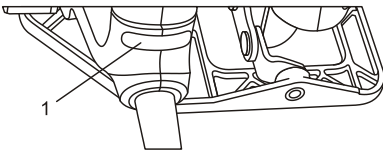

Fig. 8

LED WORKLIGHT

The LED worklight (1) will turn ON automatically when the tool is plugged into the power supply (Fig. 9). It will turn OFF when the plug is removed from the power supply.

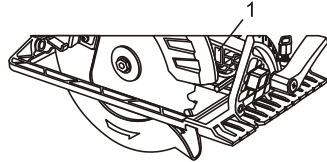

Fig. 9

⚠ WARNING

For safety reasons, the operator must read the sections of this Owner's Manual entitled "GENERAL SAFETY WARNINGS", "POWER TOOL SAFETY", "SPECIFIC SAFETY RULES", "EXTENSION CORD SAFETY" and "SYMBOLS" before using this circular saw.

Verify the following every time the circular saw is used:

1. The blade is tight and sharp.
2. All adjustments are tight.
3. The workpiece is properly secured.
4. Safety glasses and hearing protection are being worn.

Failure to adhere to these safety rules can greatly increase the chances of serious injury.

ASSEMBLY AND OPERATING

TRIGGER SWITCH

1. To turn the saw ON, squeeze the trigger switch (1) (Fig. 9).

⚠ WARNING: Never carry the saw with your finger on the trigger switch. The saw could be accidentally started and cause severe personal injury.

2. To turn the saw OFF, release the trigger switch.

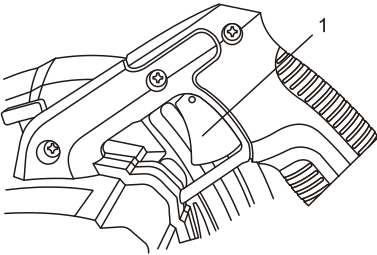

Fig. 9

MATERIALS THAT YOU CAN CUT

The circular saw is a versatile saw that allows you to cut many different types of materials.

Some of the materials include:

- Wood products such as lumber, hardwood, plywood, composit board and panelling
- Drywall
- Masonite and plastic

NOTE: There are several different types of blades available. Generally, blades with carbide-tipped teeth cut better and stay sharp longer. Tooth count and configuration are also important. High tooth counts cut slower, and are best suited for making smooth cuts on thinner materials such as panelling. Use the correct blade for your application.

GENERAL CUTTING

1. Make any adjustments to the saw before installing the blade. Adjustments include cutting depth, cutting angle and rip guide (if installed).
2. Clearly mark the workpiece to locate the position of the cut.
3. Hold a smaller workpiece with a vise. Clamp a larger workpiece to a workbench or table.

⚠ DANGER: Any workpiece that is not adequately clamped in place may come loose and cause serious injury. Never hold the workpiece in your hand.

4. Make sure there are no nails, screws, clamps or foreign materials in the path of the saw blade.
5. With both hands firmly gripping the saw, and with the blade NOT in contact with the surface to be cut, start the saw by squeezing the trigger switch.
6. Once the saw has reached full speed, place the front edge of the sole plate on the workpiece and gradually bring the moving blade into contact with the workpiece at the appropriate location.

ASSEMBLY AND OPERATING

GENERAL CUTTING – cont'd

NOTE: To align the saw blade with the cutting mark, use the guide marks on the front of the sole plate (Fig. 10). Use the 0° cutting mark (1) for right angle cuts. Use only the 45° mark (2) for 45° cuts. The 45° mark will allow for the extra material needed for the angle cut. Always make a test cut on a scrap workpiece before cutting the new material.

⚠ WARNING: Do not force the circular saw. Use only enough force to keep the blade cutting at full speed. Excessive pressure on the blade will cause it to slow down and overheat, resulting in poor cut quality and damage to the motor.

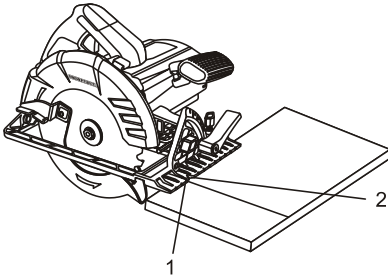

Fig. 10

RIP GUIDE CUTTING

1. Set the rip guide foot at the required width (Fig. 7).

NOTE: When starting the cut, make sure the blade is parallel to the edge of the workpiece and the rip guide foot is against the edge of the workpiece.

2. Proceed with the cut as outlined in "GENERAL CUTTING" above.

NOTE: As you move the saw through the workpiece, make sure the guide foot stays in contact with the workpiece.

PLUNGE CUTTING

⚠ WARNING: To avoid loss of control, damage to the blade or damage to the workpiece, always use extreme caution when making plunge cuts. It is not recommended to plunge cut any material other than wood.

1. To plunge cut inside the edges of a workpiece, clearly mark the cutting line on the workpiece.
2. Set the bevel angle to 0° (Fig. 5).
3. Lift the cutting depth locking lever upward to allow the blade to rise above the bottom of the sole plate so the blade will NOT contact the workpiece (Fig. 4). Do NOT lock the cutting depth locking lever.
4. Set the saw on the workpiece (1) so the sole plate is flat on the workpiece (Fig. 11).
5. Open the blade guard by rotating the blade guard lever (2) forward.
6. Align the saw blade with the cutting line (3) using the 0° cutting mark on the sole plate.

NOTE: Make sure the saw blade is inside the area to be cut out.

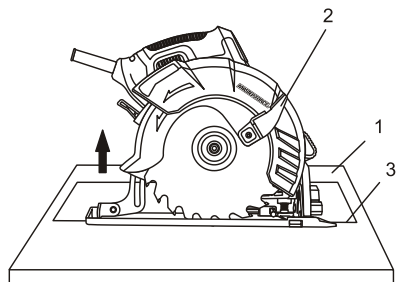

Fig. 11

ASSEMBLY AND OPERATING

PLUNGE CUTTING – cont'd

7. Start the saw and slowly lower the blade onto the workpiece while holding the blade guard lever forward to allow the blade to cut into the workpiece (Fig. 12). Allow the blade to cut through the wood.
8. Continue lowering the blade into the workpiece until the full cutting depth has been achieved. Continue sawing toward the cutting line and complete the cut as required.

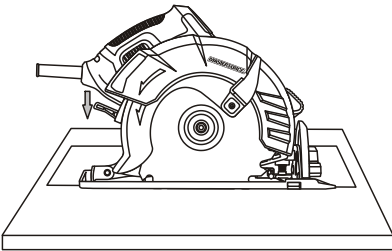

Fig. 12

MAINTENANCE

GENERAL

▲ WARNING: When servicing, use only identical replacement parts. The use of any other part may create a hazard or cause product damage.

DO NOT use solvents when cleaning plastic parts. Plastics are susceptible to damage from various types of commercial solvents and may be damaged by their use. Use a clean cloth to remove dirt, dust, oil, grease etc.

▲ WARNING: Do not allow brake fluids, gasoline, petroleum-based products, penetrating oils, etc. to come into contact with plastic parts. They contain chemicals that can damage, weaken or destroy plastic.

MAINTENANCE

DO NOT abuse power tools. Abusive practices can damage the tool and the workpiece.

▲ WARNING: DO NOT attempt to modify tools or create accessories. Any such alteration or modification is misuse and could result in a hazardous condition leading to possible serious injury. It will also void the warranty.

It has been found that electric tools are subjected to accelerated wear and possible premature failure when they are used on fiberglass boats and sports cars, wallboard, spackling compounds or plaster. The chips and grindings from these materials are highly abrasive to electric tool parts such as bearings, brushes, commutators, etc. Consequently, it is not recommended that this tool be used for extended work on any fiberglass material, wallboard, spackling compounds or plaster. During any use on these materials it is extremely important that the tool is cleaned frequently by blowing it out with an air jet.

▲ WARNING: Always wear safety goggles or safety glasses with side shields during all cutting operations. It is critical that you also wear safety goggles or safety glasses with side shields and a dust mask while blowing dust out of the circular saw with an air jet. Failure to take these safety precautions could result in permanent eye or lung damage.

If the motor brushes require replacement, contact the toll free customer support line: 1-866-349-8665 Monday – Friday from 9am to 5pm Eastern Standard Time

LUBRICATION

All of the bearings in this tool are lubricated with a sufficient amount of high-grade lubricant for the life of the unit under normal conditions. Therefore, no further lubrication is required.

EXPLODED VIEW

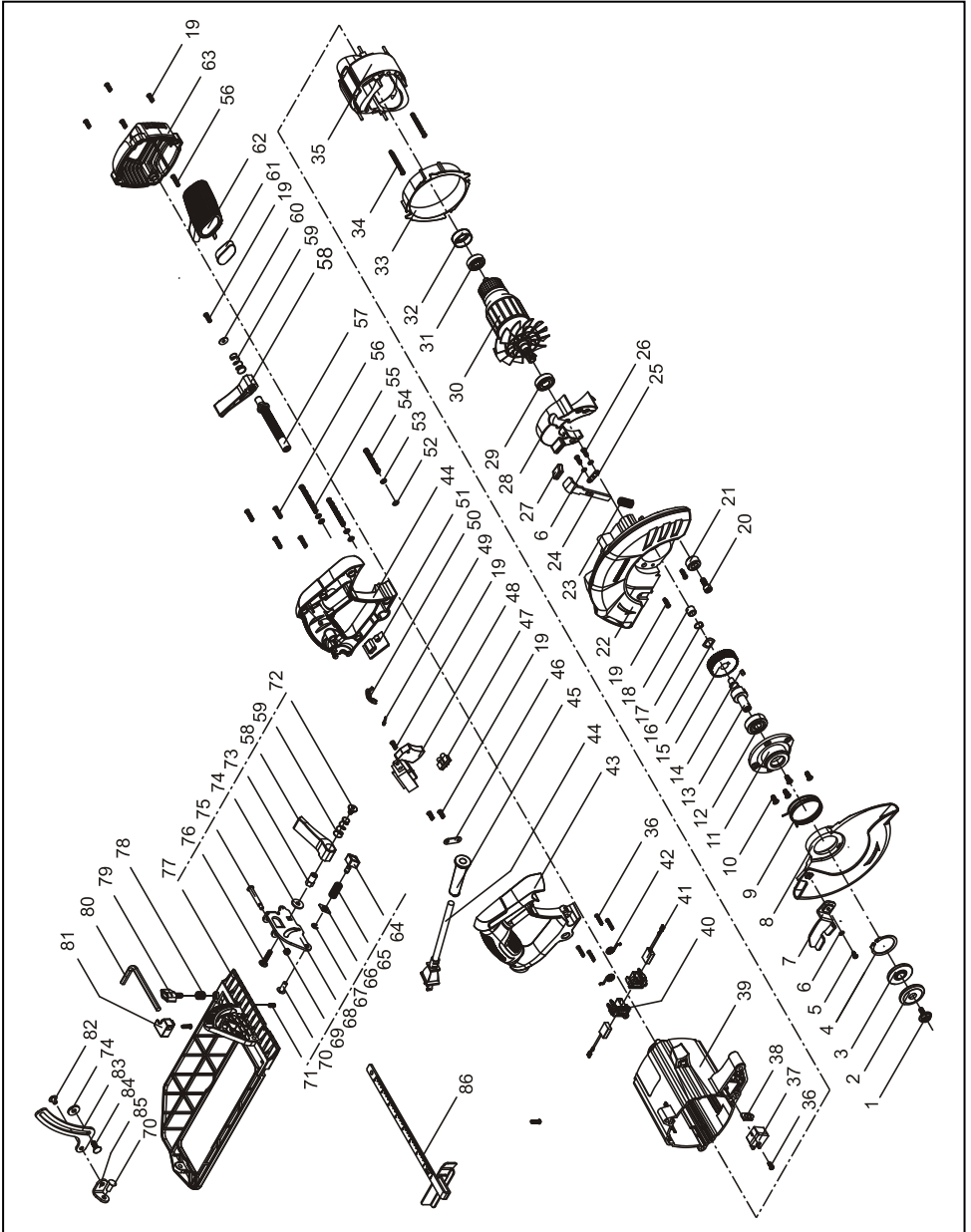

PARTS LIST

▲ WARNING: When servicing, use only original equipment replacement parts. The use of any other parts may create a safety hazard or cause damage to the circular saw.

Any attempt to repair or replace electrical parts on this circular saw may create a safety hazard unless repairs are performed by a qualified technician. For more information, call the Toll-free Helpline, at 1-866-349-8665 – Friday from 9am to 5pm Eastern Standard Time.

Always order by PART NUMBER, not by key number.

Key #	Part #	Part Name	Quantity
1	4050050006	Hex screw M8X16	1
2	2040210039	Outer flange	1
3	2040210003	Inner flange	1
4	4100020009	Circlip for shaft Φ36	1
5	4020010001	M4x8 screw	1
6	4040030001	Spring washer 4mm	3
7	2030030231	Lower guard lever	1
8	2020080040	Lower guard	1
9	2050050043	Lower guard spring	1
10	4020020005	Screw M5x12	4
11	2020150070	Gear cover	1
12	4010010081	Bearing 6201 2RS	1
13	2040040090	Output gear	1
14	4120010003	Flat key	1
15	2040080031	Output gear	1
16	4040020002	Spring washer Φ12	1
17	4100020008	Circlip for shaft Φ12	1
18	4010020003	Needle bearing HK0810	1
19	4030010096	Tapping screw 4x12	11
20	4020080007	Hex head screw M6x16	1
21	3140090020	Rubber cover for locking bolt	1
22	2020020035	Gear housing	1
23	2050040051	Spindle lock spring	1
24	2030250013	Spindle lock	1
25	2030160122	Spindle lock plate	1
26	4020010006	Screw M4x12	2
27	3140070020	Spindle lock cover	1
28	3150050080	Exhaust air deflector	1
29	4010010055	Bearing 6001 2RS	1
30	1010120014	Motor rotor	1
31	4010010014	Bearing 629 2RS	1
32	3140040012	629 Bearing sleeve	1
33	3150050074	Air deflector	1
34	4030010124	Tapping screw 5x45	2
35	1020120014	Motor stator	1
36	4030010034	Tapping screw 3x16	5
37	3160060060	Lamp cover	1
38	1220040022	Lamp LED	1
39	3011120009	Motor housing	1
40	1230030012	Carbon brush box	2

PARTS LIST

Key #	Part #	Part Name	Quantity
41	1230010123	Carbon brush	2
42	2050020028	Volute spring	2
43	3120070111	Handle	1
44	1190030051	UL power cable	1
45	3140010080	Cable guard	1
46	2030050003	Cable anchor	1
47	1250010007	Wiring terminal	1
48	1062020054	Switch	1
49	1220040023	Electric indicator LED	1
50	3160060059	Electric indicator lamp	1
51	1220040022	Lamp breadboard	1
52	4040010012	Flat washer $\Phi 5$	3
53	4040030003	Spring washer $\Phi 5$	3
54	4020010138	Screw M5x45	1
55	4020010035	Screw M5x60	2
56	4030010106	Tapping screw 4x19	5
57	1180100009	Depth adjusting rod	1
58	3120100048	Angle lever	2
59	2050040054	Angle lever spring	2
60	2030020269	Flat washer $\Phi 4$	1
61	3160090088	AUX handle cover	1
62	3120070110	AUX handle	1
63	3160010060	Motor cover	1
64	1160010019	45° Angle button	1
65	2050040055	45° Angle button spring	1
66	3150240023	45° Angle button plate	1
67	4100050005	45° Circlip for shaft $\Phi 5$	1
68	2030100059	Angle adjusting support	1
69	4060090001	Hex lock nut	1
70	4090040015	Rivet $\Phi 6 \times 15$	2
71	4020150006	Screw M5x10	1
72	2040140051	M6x10 screw	1
73	2040150023	M6x19 screw	1
74	2030020017	Flat washer 6mm	2
75	2040140001	M5x39 Special screw	1
76	4050040005	Cup head square neck bolt M6x25	1
77	2020120042	Base plate	1
78	2050060010	Edge guide spring	1
79	1160030071	Edge guide knob	1
80	6140020015	Hex key	1
81	3150160182	Hex key holder	1
82	4090040004	Rivet $\Phi 6 \times 8$	1
83	2030100058	Depth adjusting support	1
84	4050040007	Cup head square neck bolt M6x15	1
85	2030100051	Depth adjusting link	1
86	6220040014	Edge guide	1



MASTERFORCE® 15 AMP CIRCULAR SAW WARRANTY

90-DAY MONEY BACK GUARANTEE:

This MASTERFORCE® brand power tool carries our 90-Day Money Back Guarantee. If you are not completely satisfied with your MASTERFORCE® brand power tool for any reason within ninety (90) days from the date of purchase, return the tool with your original receipt to any MENARDS® retail store, and we will provide you a refund – no questions asked.

3-YEAR LIMITED WARRANTY:

This MASTERFORCE® brand power tool carries our famous No Hassle 3-Year Limited Warranty to the original purchaser. If, during normal use, this MASTERFORCE® power tool breaks or fails due to a defect in material or workmanship within three (3) years from the date of original purchase, simply bring the tool with the original sales receipt back to your nearest MENARDS® retail store. At its discretion, MASTERFORCE® agrees to have the tool or any defective part(s) repaired or replaced with the same or similar MASTERFORCE® product or part free of charge, within the stated warranty period, when returned by the original purchaser with original sales receipt. Notwithstanding the foregoing, this limited warranty does not cover any damage that has resulted from abuse or misuse of the Merchandise. This warranty: (1) excludes expendable parts including but not limited to blades, brushes, belts, bits, light bulbs, and/or batteries; (2) shall be void if this tool is used for commercial and/or rental purposes; and (3) does not cover any losses, injuries to persons/property or costs. This warranty does give you specific legal rights and you may have other rights, which vary from state to state. Be careful, tools are dangerous if improperly used or maintained. Seller's employees are not qualified to advise you on the use of this Merchandise. Any oral representation(s) made will not be binding on seller or its employees. The rights under this limited warranty are to the original purchaser of the Merchandise and may not be transferred to any subsequent owner. This limited warranty is in lieu of all warranties, expressed or implied including warranties or merchantability and fitness for a particular purpose. Seller shall not be liable for any special, incidental, or consequential damages. The sole exclusive remedy against the seller will be for the replacement of any defects as provided herein, as long as the seller is willing or able to replace this product or is willing to refund the purchase price as provided above. For insurance purposes seller is not allowed to demonstrate any of these power tools for you.

For questions / comments, technical assistance or repair parts –
Please call toll free at: 1-866-349-8665 (M-F 9am – 5pm).

**SAVE YOUR RECEIPTS
THIS WARRANTY IS VOID WITHOUT THEM**

MASTERFORCE[®]

MENARDS[®]