

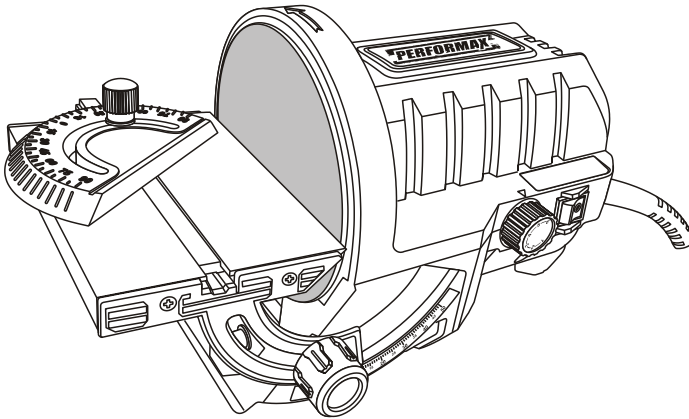

5" BENCH TOP DISC SANDER

240-2905

Owner's Manual



PRODUCT SPECIFICATIONS

Rating:	120 V, 60 Hz AC
Amperes:	1.1 A
Speed:	1,150 – 3,600 RPM (no load)
Disc diameter:	5" (125mm) self-adhesive surface
Sanding table dimensions:	5 $\frac{5}{8}$ " x 3 $\frac{7}{8}$ "
Weight:	5 lb. 8 oz. (2.49 kg)

Need Assistance?

Call us on our toll free customer support line:
1-866-349-8665 (Monday through Friday 9am – 5pm
Eastern Time)

- Technical questions
- Replacement parts
- Parts missing from package

Or email us at: customerservice@powertoolsplus.ca

TABLE OF CONTENTS

Product specifications	1
Table of contents	2
General safety warnings	3-4
Eye, ear & lung protection	3-4
Electrical safety	4
Power tool safety	5-6
Work area safety	5
Electrical safety	5
Personal safety	5-6
Power tool use and care	6
Service	6
Specific safety rules	7
Guidelines for extension cords	8
Symbols	9
Know your bench top sander	10
Assembly and operating	11-14
Clamping the sander to a workbench	11
Removing the sanding table assembly	11
Removing and installing sandpaper	11-12
ON/OFF switch	12
Speed control knob	12
Adjusting the sanding table angle	12
Adjusting the miter angle	13
Sanding	14
Installing the vacuum hose adaptor	14
Maintenance	15
Exploded view	16
Parts list	17-18
Warranty	19

GENERAL SAFETY WARNINGS



WARNING: Before using this tool or any of its accessories, read this manual and follow all Safety Rules and Operating Instructions. The important precautions, safeguards and instructions appearing in this manual are not meant to cover all possible situations. It must be understood that common sense and caution are factors which cannot be built into the product.

This instruction manual includes the following:

- General Safety Rules
- Specific Safety Rules and Symbols
- Functional Description
- Assembly
- Operation
- Maintenance
- Accessories

EYE, EAR & LUNG PROTECTION



ALWAYS WEAR EYE PROTECTION THAT CONFORMS WITH CSA REQUIREMENTS or ANSI SAFETY STANDARD Z87.1

FLYING DEBRIS can cause permanent eye damage. Prescription eyeglasses ARE NOT a replacement for proper eye protection.



WARNING: Non-compliant eyewear can cause serious injury if broken during the operation of a power tool.



WARNING: Use hearing protection, particularly during extended periods of operation of the tool, or if the operation is noisy.

SAVE THESE INSTRUCTIONS FOR REFERENCE

GENERAL SAFETY WARNINGS



WEAR A DUST MASK THAT IS DESIGNED TO BE USED WHEN OPERATING A POWER TOOL IN A DUSTY ENVIRONMENT.



WARNING: Dust that is created by power sanding, sawing, grinding, drilling, and other construction activities may contain chemicals that are known to cause cancer, birth defects, or other genetic abnormalities. These chemicals include:

Lead from lead-based paints
Crystalline silica from bricks, cement, and other masonry products
Arsenic and chromium from chemically treated lumber

The level of risk from exposure to these chemicals varies, according to how often this type of work is performed. In order to reduce exposure to these chemicals, work in a well-ventilated area, and use approved safety equipment, such as a dust mask that is specifically designed to filter out microscopic particles.

ELECTRICAL SAFETY



WARNING: To avoid electrical hazards, fire hazards or damage to the tool, use proper circuit protection.

This tool is wired at the factory for 120 V AC operation. It must be connected to a 120 V AC, 15 A circuit that is protected by a time-delayed fuse or circuit breaker. To avoid shock or fire, replace power cord immediately if it is worn, cut or damaged in any way.

SAVE THESE INSTRUCTIONS FOR REFERENCE

POWER TOOL SAFETY

▲ WARNING: Read all safety warnings and instructions. Failure to follow the warnings and instructions may result in electric shock, fire and/or serious injury.

Save all warnings and instructions for future reference.

Work area safety

Keep work area clean and well lit. Cluttered or dark areas invite accidents.

Do not operate power tools in explosive atmospheres, such as in the presence of flammable liquids, gases or dust. Power tools create sparks which may ignite the dust or fumes.

Keep children and bystanders away while operating a power tool. Distractions can cause you to lose control.

Electrical safety

Power tool plugs must match the outlet. Never modify the plug in any way. Do not use any adapter plugs with earthed (grounded) power tools. Unmodified plugs and matching outlets will reduce risk of electric shock.

Avoid body contact with earthed or grounded surfaces such as pipes, radiators, ranges and refrigerators. There is an increased risk of electric shock if your body is earthed or grounded.

Do not expose power tools to rain or wet conditions. Water entering a power tool will increase the risk of electric shock.

Do not abuse the cord. Never use the cord for carrying, pulling or unplugging the power tool. Keep cord away from heat, oil, sharp edges or moving parts. Damaged or entangled cords increase the risk of electric shock.

When operating a power tool outdoors, use an extension cord suitable for outdoor use. Use of a cord suitable for outdoor use reduces the risk of electric shock.

If operating a power tool in a damp location is unavoidable, use a residual current device (RCD) protected supply. Use of a ground fault circuit interrupter (GFCI) reduces the risk of electric shock.

Personal safety

Stay alert, watch what you are doing and use common sense when operating a power tool. Do not use a power tool while you are tired or under the influence of drugs, alcohol or medication. A moment of inattention while operating power tools may result in serious personal injury.

Use personal protective equipment. Always wear eye protection. Protective equipment such as dust mask, non-skid safety shoes, hard hat, or hearing protection used for appropriate conditions will reduce personal injuries.

Prevent unintentional starting. Ensure the switch is in the off-position before connecting to power source and/or battery pack, picking up or carrying the tool. Carrying power tools with your finger on the switch or energizing power tools that have the switch on invites accidents.

Remove any adjusting key or wrench before turning the power tool on. A wrench or a key left attached to a rotating part of the power tool may result in personal injury.

Do not overreach. Keep proper footing and balance at all times. This enables better control of the power tool in unexpected situations.

Dress properly. Do not wear loose clothing or jewelry. Keep your hair, clothing and gloves away from moving parts. Loose clothes, jewelry or long hair can be caught in moving parts.

SAVE THESE INSTRUCTIONS FOR REFERENCE

POWER TOOL SAFETY

Personal safety – cont'd

If devices are provided for the connection of dust extraction and collection facilities, ensure these are connected and properly used. Use of dust collection can reduce dust-related hazards.

Power tool use and care

Do not force the power tool. Use the correct power tool for your application. The correct power tool will do the job better and safer at the rate for which it was designed.

Do not use the power tool if the switch does not turn it on and off. Any power tool that cannot be controlled with the switch is dangerous and must be repaired.

Disconnect the plug from the power source and/or the battery pack from the power tool before making any adjustments, changing accessories, or storing power tools. Such preventive safety measures reduce the risk of starting the power tool accidentally.

Store idle power tools out of the reach of children and do not allow persons unfamiliar with the power tool or these instructions to operate the power tool. Power tools are dangerous in the hands of untrained users.

Maintain power tools. Check for misalignment or binding of moving parts, breakage of parts and any other condition that may affect the power tool's operation. If damaged, have the power tool repaired before use. Many accidents are caused by poorly maintained power tools.

Keep cutting tools sharp and clean. Properly maintained cutting tools with sharp cutting edges are less likely to bind and are easier to control.

Use the power tool, accessories and tool bits etc. in accordance with these instructions, taking into account the working conditions and the work to be performed. Use of the power tool for operations different from those intended could result in a hazardous situation.

Service

Have your power tool serviced by a qualified repair person using only identical replacement parts. This will ensure that the safety of the power tool is maintained.

SAVE THESE INSTRUCTIONS FOR REFERENCE

SPECIFIC SAFETY RULES

⚠ WARNING: Know your bench top sander. Do not plug in the sander until you have read and understand this Instruction Manual. Learn the tool's applications and limitations, as well as the specific potential hazards related to this tool. Following this rule will reduce the risk of electric shock, fire, or serious injury.



Always wear eye protection. Any power tool can throw foreign objects into your eyes and cause permanent eye damage.

ALWAYS wear safety goggles (not glasses) that comply with ANSI safety standard Z87.1. Everyday glasses have only impact resistant lenses. They ARE NOT safety glasses.

⚠ WARNING: Glasses or goggles not in compliance with ANSI Z87.1 could cause serious injury when they break.

⚠ WARNING: Always use a dust mask when sanding.

⚠ WARNING: Always use hearing protection when sanding, particularly during extended periods of operation.

⚠ WARNING: Always unplug the tool from the power source before changing the sandpaper and when cleaning the tool.

Do not wear gloves, neckties or loose clothing.

Never sand material too small to be securely held.

Make sure there are no nails or foreign objects in the part of the workpiece to be sanded.

⚠ WARNING: When sanding, it is important to maintain control of the workpiece by firmly holding it down onto the sanding table and against the miter gauge (if the miter gauge is being used). A workpiece that is not held tightly may become uncontrollable. This is particularly important when the length of the sanding surface of the workpiece exceeds 2" (26 mm). The sanding surface of large workpieces will contact the upward moving portion of the sanding disc and the workpiece will be prone to lifting off the sanding table, possibly causing loss of control and injury to the operator.

Always keep hands out of the path of the sanding pad. Avoid awkward hand positions where a sudden slip could cause your hand to move into the path of the sanding disc.

To avoid injury from accidental starting, always remove the plug from the power source before installing or removing sandpaper or the vacuum adaptor.

SAVE THESE INSTRUCTIONS FOR REFERENCE

GUIDELINES FOR EXTENSION CORDS

Make sure your extension cord is the proper size. When using an extension cord, be sure to use one heavy enough to carry the current the tool will draw. An undersized cord will cause a drop in line voltage resulting in loss of power and overheating. The table on the right shows the correct size to use according to cord length and nameplate ampere rating. If in doubt, use the next heavier gauge. The smaller the gauge number the heavier the cord.

Be sure your extension cord is properly wired and in good condition. Always replace a damaged extension cord or have it repaired by a qualified electrician before using it. Protect your extension cord from sharp objects, excessive heat and damp or wet areas.

Use a separate electrical circuit for your power tools. This circuit must not be less than 14 gauge wire and should be protected with either a 15A time delay fuse or circuit breaker. Before connecting the power tool to the power source, make sure the switch is in the OFF position and the power source is the same as indicated on the nameplate. Running at lower voltage will damage the motor.

⚠ WARNING: Repair or replace damaged or worn extension cords immediately.

Select the appropriate extension cord gauge and length using the chart on the right.

When operating a power tool outdoors, use an outdoor extension cord marked “W - A” or “W”. These cords are rated for outdoor use and reduce the risk of electric shock.

⚠ WARNING: Keep the extension cord clear of the working area. Position the cord so it will not get caught on the workpiece, tools or any other obstructions while you are working with the power tool.











MINIMUM GAUGE (AWG) EXTENSION CORDS (120 V use only)					
Ampere rating		Total length in feet			
More than	Not more than	7.5 m (25')	15 m (50')	30 m (100')	45 m (150')
0	6	18	16	16	14
6	10	18	16	14	12
10	12	16	16	14	12
12	16	14	12	Not Applicable	

SAVE THESE INSTRUCTIONS FOR REFERENCE

SYMBOLS

▲ WARNING: Some of the following symbols may appear on the bench top sander. Study these symbols and learn their meaning. Proper interpretation of these symbols will allow for more efficient and safer operation of this tool.

V	Volts
A	Amperes
Hz	Hertz
W	Watts
kW	Kilowatts
μF	Microfarads
L	Liters
kg	Kilograms
H	Hours
N/cm ²	Newtons per square centimeter
Pa	Pascals
OPM	Oscillations per minute
Min	Minutes
S	Seconds
 or a.c.	Alternating current
	Three-phase alternating current
	Three-phase alternating current with neutral

	Direct current
n_0	No load speed
	Alternating or direct current
	Class II construction
	Splash-proof construction
	Watertight construction
	Protective grounding at grounding terminal, Class I tools
.../min	Revolutions or reciprocations per minute
∅	Diameter
0	Off position
	Directional arrow
	Warning symbol
	Wear your safety glasses
	Wear hearing protection
	Wear a dust mask



This symbol designates that this tool is listed with U.S. requirements by ETL Testing Laboratories, Inc. Conforms to UL Std. 987.

KNOW YOUR BENCH TOP SANDER

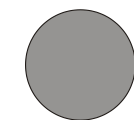
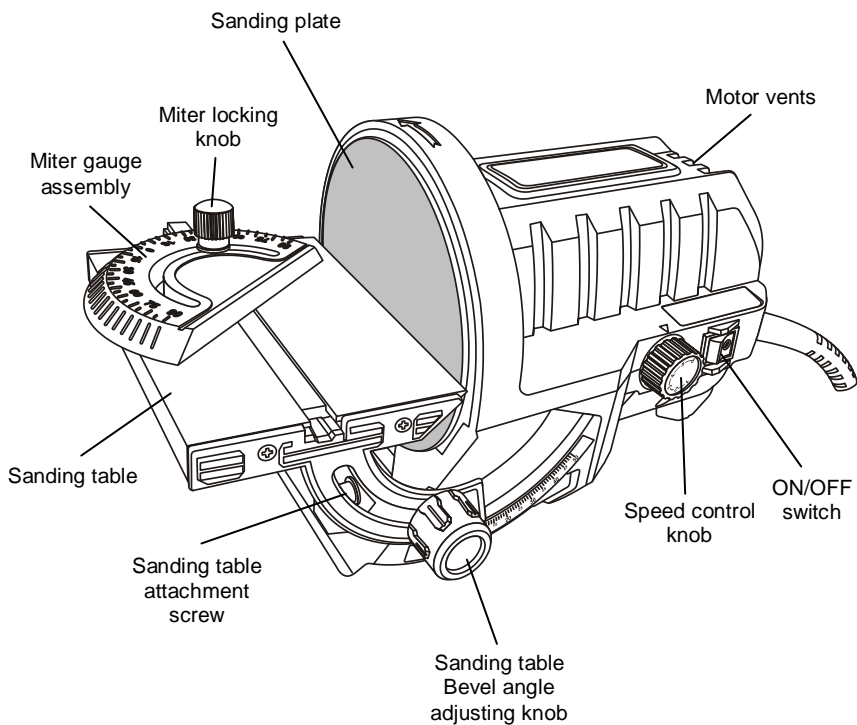

Sanding disc
2 x 80 grit

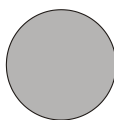

Sanding disc
2 x 150 grit

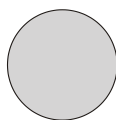

Sanding disc
2 x 240 grit

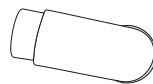

Vacuum
hose
adaptor

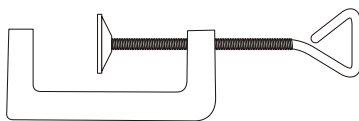

Clamp

ASSEMBLY AND OPERATING

CLAMPING THE SANDER TO A WORKBENCH

▲ WARNING: Before attempting to use the sander, it must be securely clamped to a workbench or similar stable surface. The sander may be clamped in a vertical position (Fig. 1) or in its normal horizontal position (Fig. 2) to allow the sanding disc to be in a vertical position at a right angle to the work bench.

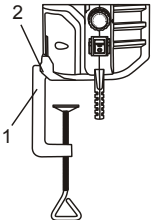

Fig. 1

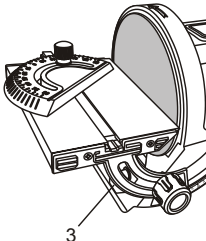

Fig. 2

To clamp the sander to the workbench in the desired position, simply open the threaded clamp screw, insert the top of the clamp (1) into the clamping cavity (2 or 3) and tighten the clamp screw until the sander is securely locked onto the workbench.

REMOVING THE SANDING TABLE ASSEMBLY

NOTE: The sanding table assembly must be removed before attempting to install sandpaper onto the sanding plate.

▲ WARNING: Remove the plug from the power source before removing the sanding table assembly.

1. Insert the 5mm hex key (1) supplied into the sanding table assembly mounting screw (2) (Fig. 3).
2. Turn the mounting screw counterclockwise until both the screw and the washer can be removed.

3. Slide the sanding table assembly (3) outward away from the sanding plate.

NOTE: Once the sanding table has been removed, the sanding disc can be removed or installed as outlined in Fig. 4 below.

4. To reinstall the sanding table assembly, place it against the bottom of the motor housing (4) and slide it toward the sanding plate.

NOTE: Make sure the positioning tabs are fully inserted into the matching slots in the motor housing.

5. Reinstall the sanding table mounting screw and washer and tighten it using the 5mm hex key.

NOTE: Do not overtighten the screw. You may damage the motor housing.

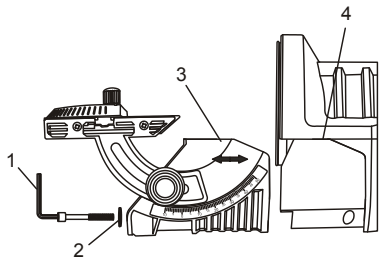

Fig. 3

REMOVING AND INSTALLING SANDPAPER

▲ WARNING: Remove the plug from the power source before removing or installing sandpaper.

1. Remove the sanding table assembly as noted above.
2. Peel the old sandpaper (1) from the plate (2) (Fig. 4).
3. Peel the protective paper from the new sandpaper.

ASSEMBLY AND OPERATING

REMOVING AND INSTALLING SANDPAPER – cont'd

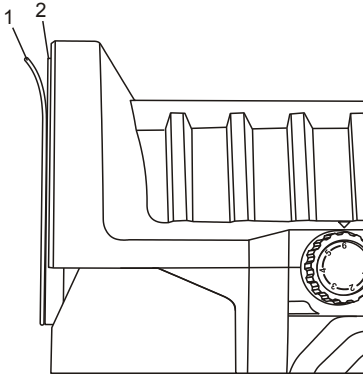

Fig. 4

4. Clean all sanding dust and debris from the face of the plate.

NOTE: Any dust or debris on the plate will prevent the sandpaper from properly adhering to the plate.

5. Carefully place the glued side of the new sanding disc onto the sanding plate.

⚠ WARNING: The new sandpaper **MUST** be centered and firmly pressed onto the plate to prevent vibration and the possibility of the sandpaper flying off the plate when the sander is turned ON. Serious injury could result from flying sandpaper.

ON/OFF SWITCH

To turn the sander ON, press the front of the ON/OFF switch (1) Fig. 5. To turn the sander OFF, press the rear of the ON/OFF switch.

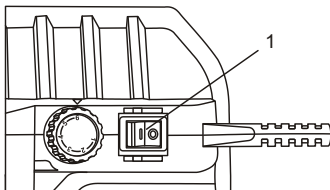

Fig. 5

SPEED CONTROL KNOB

The speed of the sander can be adjusted to suit the need. To set the sander speed, rotate the speed control knob (2) (Fig. 6). For the fastest speed, set the speed control knob at #6. For the slowest speed, set the speed control knob at #1.

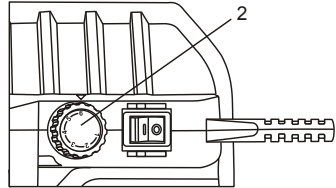

Fig. 6

ADJUSTING THE SANDING TABLE ANGLE

The sanding table can be tilted from upward 10° to downward 50°. Set the sanding table angle as follows:

1. Loosen the table angle adjustment knob (1) by turning it counterclockwise (Fig. 7).

NOTE: If the adjustment knob does not loosen, hold the adjustment knob on the opposite side of the sanding table while loosening adjustment Knob (1).

2. When the sanding table adjustment knob is loose enough, rotate the table downward until the desired angle (2) is aligned with the indexing mark (3).

3. Tighten the sanding table adjustment knob.

NOTE: Tighten the adjustment knob with your hand only. Do not use pliers as you may overtighten and damage the knob.

4. Test sand a scrap workpiece to make sure the sanding table angle is correct.

ASSEMBLY AND OPERATING

ADJUSTING THE SANDING TABLE ANGLE – cont'd

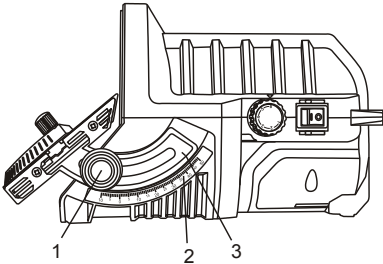

Fig. 7

ADJUSTING THE MITER ANGLE

The miter angle can be set to ensure the sanded surface is held to the correct angle.

1. Loosen the miter adjustment knob (1) by turning it counterclockwise (Fig. 8).
2. Slide the miter key (2) into the matching slot (3) in the sanding table.

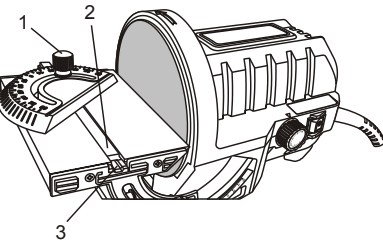

Fig. 8

3. Rotate the miter gauge (4) and align the desired angle (5) with the indexing mark (6) (Fig. 9).
4. Slide the miter gauge assembly in the table slot so the edge of the miter gauge closest to the sanding disc (7) is approximately 1/4" (6.4 mm) inside the outer edge of the sanding disc (8).

5. Tighten the miter adjusting knob.
NOTE: When the adjusting knob is tightened, the miter angle will be locked and the miter assembly will be locked in position in the sanding table slot.

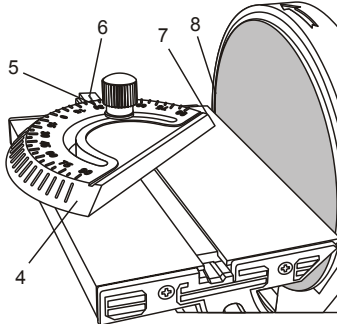

Fig. 9

6. Test sand a scrap workpiece to make sure the miter angle is correct.

⚠ WARNING

For safety reasons, the operator must read the sections of this Owner's Manual entitled "GENERAL SAFETY WARNINGS", "POWER TOOL SAFETY", "SPECIFIC SAFETY RULES", "GUIDELINES FOR EXTENSION CORDS" and "SYMBOLS" before using this disc sander.

Verify the following every time the disc sander is used:

1. Sander cord is not damaged.
2. Safety glasses and dust mask are being worn.
3. Hearing protection is being worn.
4. Sandpaper is the correct type for the job.
5. Sandpaper is in good condition and is properly installed.
6. The workpiece is not too small to be firmly held while sanding.

Failure to observe these safety rules will significantly increase the risk of injury.

ASSEMBLY AND OPERATING

SANDING

This sander is well suited for fine sanding work and for making minor material corrections. Materials that may be sanded with this sander include all types of wood, steel, non-ferrous and precious metals, plastics, plexiglass and fiberglass.

▲ WARNING: When sanding, it is important to maintain control of the workpiece by firmly holding it down onto the sanding table and against the miter gauge (if the miter gauge is being used) (Fig. 10). A workpiece that is not held tightly may become uncontrollable. This is particularly important when the length of the sanding surface of the workpiece exceeds 2" (50.8 mm). The sanding surface of large workpieces will contact the upward moving portion of the sanding disc and the workpiece will be prone to lifting off the sanding table, possibly causing loss of control and injury to the operator. Never sand any workpiece that is too small to be firmly held.

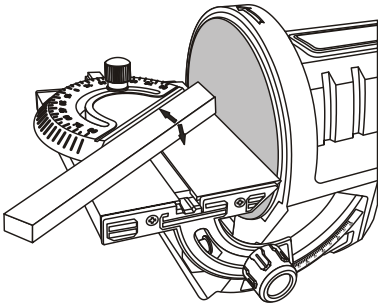

Fig. 10

It is usually better to use the sander at its maximum speed setting. Faster speeds will remove material faster and produce a smoother finish. Using coarse sandpaper will also facilitate faster material removal, but produce a rougher finish. When using the sander to sand soft metals and plastics, using coarser sandpaper and slower sander speeds will lower the risk of the material overheating and plugging up the sandpaper.

INSTALLING THE VACUUM HOSE ADAPTOR

When using the sander for prolonged periods of time, a vacuum can be attached to the sander to help reduce the amount of dust escaping into the work area. To attach a vacuum hose to the sander, insert the vacuum hose adaptor and ensure the "notch" on the adaptor is aligned with the slot in the inner edge of the tool's dust port. Once inserted, turn the adapter clockwise or counterclockwise, whichever best suits the position of the tool and/ or that of the vacuum. Insert the vacuum hose end onto the free end of the vacuum hose adaptor. Please note that the end of the adaptor fits most standard vacuum hose ends.

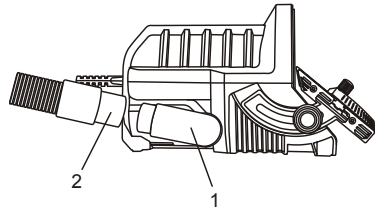

Fig. 11

MAINTENANCE

GENERAL

⚠ WARNING: When servicing, use only identical replacement parts. Use of any other replacement parts may create a hazard or cause product damage.

DO NOT use solvents when cleaning plastic parts. Most plastics are susceptible to damage from various types of commercial solvents and may be damaged by their use. Use a clean cloth to remove dirt, dust, oil, grease etc.

⚠ WARNING: Do not at any time allow brake fluids, gasoline, petroleum-based products, penetrating oils, etc. to come in contact with plastic parts. They contain chemicals that can damage, weaken or destroy plastic.

DO NOT abuse power tools. Abusive practices can damage the tool as well as the workpiece.

⚠ WARNING: DO NOT attempt to modify tools or create accessories not recommended. Any such alteration or modification is misuse and could result in a hazardous condition leading to possible serious injury. It will also void the warranty.

It has been found that electric tools are subjected to accelerated wear and possible premature failure when they are used on fiberglass boats and automotive parts, wallboard, spackling compounds or plaster. The chips and grindings from these materials are highly abrasive to electric tool parts such as bearings, brushes, commutators, etc. Consequently, it is not recommended that this tool be used for extended work on any fiberglass material, wallboard, spackling compounds or plaster. During any use on these materials it is extremely important that the tool is cleaned frequently by blowing the dust out of the tool with an air jet.

⚠ WARNING: Always wear safety goggles or safety glasses with side shields during all sanding operations. It is critical that you also wear safety goggles or safety glasses with side shields and a dust mask while blowing dust out of the sander with an air jet. Failure to take these safety precautions could result in permanent eye or lung damage.

LUBRICATION

All of the bearings in this sander are lubricated with a sufficient amount of high grade lubricant for the life of the unit under normal conditions. Therefore, no further lubrication is required.

EXPLODED VIEW

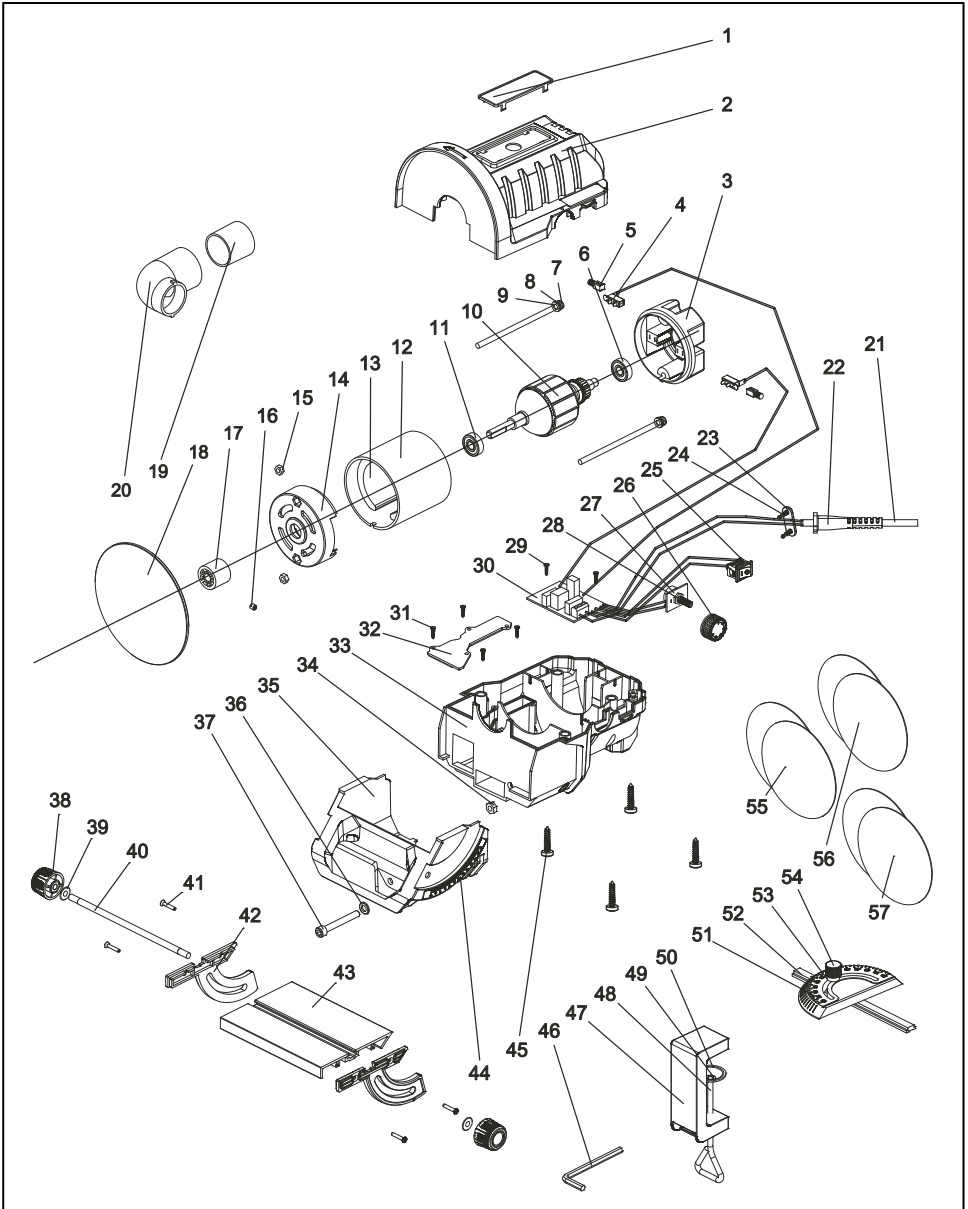

PARTS LIST

▲ WARNING: When servicing, use only original equipment replacement parts. The use of any other parts may create a safety hazard or cause damage to the sander.

Any attempt to repair or replace electrical parts on this sander may create a safety hazard unless repairs are performed by a qualified technician. For more information, call the Toll-free Helpline, at 1-866-349-8665 Eastern Time.

Always order by PART NUMBER, not by key number.

Key #	Part #	Part Name	Quantity
1	3110030023	Label plate	1
2	3011060032	Upper housing	1
3	3160050011	Motor end cover	1 set
4	2030070055	Brush holder	2
5	1230010155	Brush	2
6	4010010048	Bearing 608-2s	1
7	4020010186	Screw M5*10	2
8	4040030003	Snap washer $\phi 5$	2
9	4040010011	Washer $\phi 5 \times \phi 10 \times 0.8$	2
10	1010060035	Rotor	1
11	4010010048	Bearing 608-2rs	1
12	2040310053	Stator sleeve	1
13	2010170031	Magnet block	2
14	3160050011	Motor cover	1 set
15	4060010021	Hex nut M5	2
16	4020150013	Screw M5*16	1
17	3150190198	Insert	1
18	2020160029	5" disc	1
19	3180040004	Dust port nipple	1
20	3180040125	Dust port elbow	1
21	1190030067	UL cord	1
22	3140010091	Cord jacket	1
23	2030050009	Cord clamp	1
24	4030010099	Screw 3.9 x 14	2
25	1061250005	Switch	1
26	3120050002	Speed setting dial	1
27	2030030284	Fix plate	1
28	1210070004	Potentiometer	4
29	4030010136	Screw ST2.9*9	1
30	1130010269	PCB	1

PARTS LIST

Key #	Part #	Part Name	Quantity
31	4030010136	Screw ST2.9*9	1
32	3180030027	Dust cover	1
33	3011060031	Lower housing	1
34	4060010019	Hex nut M6	1
35	3150160236	Table base	1
36	4040010050	Washer $\phi 6 \times \phi 13 \times 2$	1
37	4020080036	Screw M6 x 55	1
38	3120060067	Knob	2
39	4040010052	Washer $\phi 6 \times \phi 16 \times 0.8$	2
40	2040140061	Table mounting screw	1
41	4030020013	Screw T29x16	4
42	3150160237	Bevel support	1set
43	2020210012	Table	1
44	2020070024	Scale label	1
45	4030010106	Screw T3.9*19	4
46	6140020001	Hex nut M5	1
47	2020210013	Clamp	1
48	2040140060	Clamp screw rod	1
49	4100050005	Snap ring	1
50	2030030285	Clamp plate	1
51	3110040011	Miter scale	1
52	2020080045	Graduated miter bar	1
53	4040010009	Washer $\phi 5 \times \phi 12 \times 1.5$	1
54	1160030053	Miter adjustment knob	1
55	6090040020	Sanding paper P80	2
56	6090040021	Sanding paper P150	2
57	6090040022	Sanding paper P240	2

PERFORMAX® BENCH TOP SANDER WARRANTY

30-DAY MONEY BACK GUARANTEE:

This PERFORMAX® brand power tool carries our 30-Day Money Back Guarantee. If you are not completely satisfied with your PERFORMAX® brand power tool for any reason within thirty (30) days from the date of purchase, return the tool with your original receipt to any MENARDS® retail store, and we will provide you a refund – no questions asked.

2-YEAR LIMITED WARRANTY:

This PERFORMAX® brand power tool carries a 2-Year Limited Warranty to the original purchaser. If, during normal use, this PERFORMAX® power tool breaks or fails due to a defect in material or workmanship within two (2) years from the date of original purchase, simply bring this tool with the original sales receipt back to your nearest MENARDS® retail store. At its discretion, PERFORMAX® agrees to have the tool or any defective part(s) repaired or replaced with the same or similar PERFORMAX® product or part free of charge, within the stated warranty period, when returned by the original purchaser with original sales receipt. Notwithstanding the foregoing, this limited warranty does not cover any damage that has resulted from abuse or misuse of the Merchandise. This warranty: (1) excludes expendable parts including but not limited to blades, brushes, belts, bits, light bulbs, and/or batteries; (2) shall be void if this tool is used for commercial and/or rental purposes; and (3) does not cover any losses, injuries to persons/property or costs. This warranty does give you specific legal rights and you may have other rights, which vary from state to state. Be careful, tools are dangerous if improperly used or maintained. Seller's employees are not qualified to advise you on the use of this Merchandise. Any oral representation(s) made will not be binding on seller or its employees. The rights under this limited warranty are to the original purchaser of the Merchandise and may not be transferred to any subsequent owner. This limited warranty is in lieu of all warranties, expressed or implied including warranties or merchantability and fitness for a particular purpose. Seller shall not be liable for any special, incidental, or consequential damages. The sole exclusive remedy against the seller will be for the replacement of any defects as provided herein, as long as the seller is willing or able to replace this product or is willing to refund the purchase price as provided above. For insurance purposes, seller is not allowed to demonstrate any of these power tools for you.

For questions / comments, technical assistance or repair parts –
Please Call Toll Free at: 1-866-349-8665 (M-F 8am – 6pm)

SAVE YOUR RECEIPTS. THIS WARRANTY IS VOID WITHOUT THEM.

Distributed by: Menard, Inc., Eau Claire, WI 54703