

MASTERFORCE®

5/8" DRILL/MIXER

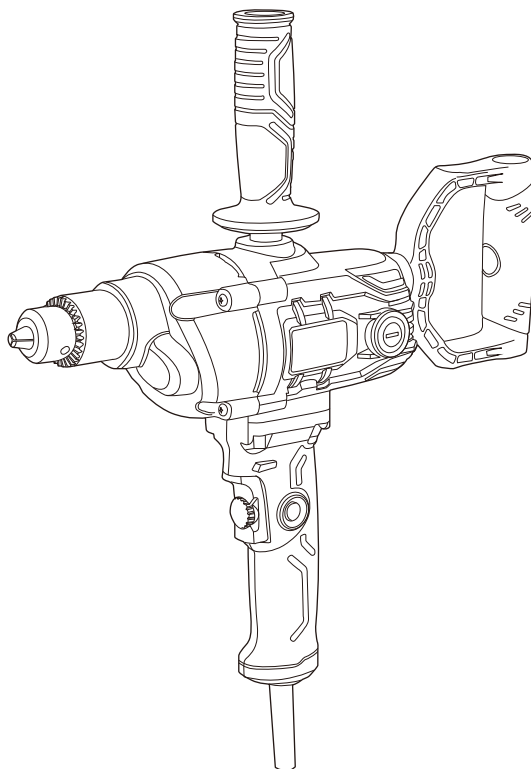

241-0725

For questions/comments, technical assistance or repair parts –
Please call toll free: 1-866-349-8665 (M–F 9am–5pm EST)
Email us at: customerservice@powertoolsplus.ca

OPERATOR'S MANUAL

⚠ CAUTION: To Reduce The Risk Of Injury, User Must Read And Understand Operator's Manual. Save These Instructions For Future Reference.

TABLE OF CONTENTS

Table of contents	2
General safety warnings	3-4
Eye, ear & lung protection	3-4
Electrical safety	4
Power tool safety	5-6
General safety rules	5
Work area	5
Electrical safety	5
Personal safety	5-6
Power tool use and care	6
Service	6
Specific safety rules	7
Extension cord safety	8
Product specifications	9
Symbols	10
Know your drill	11
Assembly and operating	12-15
Install auxiliary handle & D handle	12
Forward/reverse switch	12
Variable-speed switch and dial	12
Lock-on switch	13
Installing drill bits	13-14
Removing bits	14
Drilling	14-15
Driving screws	15
Removing the chuck	15-16
Retightening a loose chuck	16
Replacing carbon motor brushes	17
Maintenance	17
Exploded view	18
Parts list	19-20
Warranty	21

GENERAL SAFETY WARNINGS

⚠ WARNING: Before using this tool or any of its accessories, read this manual and follow all Safety Rules and Operating Instructions. The important precautions, safeguards and instructions appearing in this manual are not meant to cover all possible situations. It must be understood that common sense and caution are factors which cannot be built into the product.

This instruction manual includes the following:

- General Safety Rules
- Specific Safety Rules and Symbols
- Functional Description
- Assembly
- Operation
- Maintenance
- Accessories

EYE, EAR & LUNG PROTECTION



ALWAYS WEAR EYE PROTECTION THAT CONFORMS WITH CSA REQUIREMENTS or ANSI SAFETY STANDARD Z87.1

FLYING DEBRIS can cause permanent eye damage. Prescription eyeglasses ARE NOT a replacement for proper eye protection.



WARNING: Non-compliant eyewear can cause serious injury if broken during the operation of a power tool.



WARNING: Use hearing protection, particularly during extended periods of operation of the tool, or if the operation is noisy.

SAVE THESE INSTRUCTIONS FOR REFERENCE

POWER TOOL SAFETY

EYE, EAR & LUNG PROTECTION – cont'd



WEAR A DUST MASK THAT IS DESIGNED TO BE USED WHEN OPERATING A POWER TOOL IN A DUSTY ENVIRONMENT.



WARNING: Dust that is created by power sanding, sawing, grinding, drilling, and other construction activities may contain chemicals that are known to cause cancer, birth defects, or other genetic abnormalities. These chemicals include:

Lead from lead-based paints

Crystalline silica from bricks, cement, and other masonry products

Arsenic and chromium from chemically treated lumber

The level of risk from exposure to these chemicals varies, according to how often this type of work is performed. In order to reduce exposure to these chemicals, work in a well-ventilated area, and use approved safety equipment, such as a dust mask that is specifically designed to filter out microscopic particles.

ELECTRICAL SAFETY



WARNING: To avoid electrical hazards, fire hazards or damage to the tool, use proper circuit protection.

This tool is wired at the factory for 120 Volts AC operation. It must be connected to a 120 Volts AC, 15 Amps circuit that is protected by a time-delayed fuse or circuit breaker. To avoid shock or fire, replace power cord immediately if it is worn, cut or damaged in any way.

SAVE THESE INSTRUCTIONS FOR REFERENCE

▲ WARNING: Read all safety warnings and all instructions. Failure to follow the warnings and instructions may result in electric shock, fire and/or serious injury.

Save all warnings and instructions for future reference.

Work area safety

Keep work area clean and well lit. Cluttered or dark areas invite accidents.

Do not operate power tools in explosive atmospheres, such as in the presence of flammable liquids, gases or dust. Power tools create sparks which may ignite the dust or fumes.

Keep children and bystanders away while operating a power tool. Distractions can cause you to lose control.

Electrical safety

Power tool plugs must match the outlet. Never modify the plug in any way. Do not use any adapter plugs with earthed (grounded) power tools. Unmodified plugs and matching outlets will reduce risk of electric shock.

Avoid body contact with earthed or grounded surfaces such as pipes, radiators, ranges and refrigerators. There is an increased risk of electric shock if your body is earthed or grounded.

Do not expose power tools to rain or wet conditions. Water entering a power tool will increase the risk of electric shock.

Do not abuse the cord. Never use the cord for carrying, pulling or unplugging the power tool. Keep cord away from heat, oil, sharp edges or moving parts. Damaged or entangled cords increase the risk of electric shock.

When operating a power tool outdoors, use an extension cord suitable for outdoor use. Use of a cord suitable for outdoor use reduces the risk of electric shock.

If operating a power tool in a damp location is unavoidable, use a residual current device (RCD) protected supply. Use of a ground fault circuit interrupter (GFCI) protected supply. Use of a ground fault circuit interrupter (GFCI) reduces the risk of electric shock.

Personal safety

Stay alert, watch what you are doing and use common sense when operating a power tool. Do not use a power tool while you are tired or under the influence of drugs, alcohol, or medication. A moment of inattention while operating power tools may result in serious personal injury.

Use personal protective equipment. Always wear eye protection. Protective equipment such as dust mask, non-skid safety shoes, hard hat, or hearing protection used for appropriate conditions will reduce personal injuries.

Prevent unintentional starting. Ensure the switch is in the off-position before connecting to power source and/or battery pack, picking up or carrying the tool. Carrying power tools with your finger on the switch or energizing power tools that have the switch on invites accidents.

Remove any adjusting key or wrench before turning the power tool on. A wrench or a key left attached to a rotating part of the power tool may result in personal injury.

Do not overreach. Keep proper footing and balance at all times. This enables better control of the power tool in unexpected situations.

SAVE THESE INSTRUCTIONS FOR REFERENCE

POWER TOOL SAFETY

PERSONAL SAFETY – cont'd

Dress properly. Do not wear loose clothing or jewelry. Keep your hair, clothing, and gloves away from moving parts. Loose clothes, jewelry or long hair can be caught in moving parts.

If devices are provided for the connection of dust extraction and collection facilities, ensure these are connected and properly used. Use of dust collection can reduce dust-related hazards.

Power tool use and care

Do not force the power tool. Use the correct power tool for your application. The correct power tool will do the job better and safer at the rate for which it was designed.

Do not use the power tool if the switch does not turn it on and off. Any power tool that cannot be controlled with the switch is dangerous and must be repaired.

Disconnect the plug from the power source and/or the battery pack from the power tool before making any adjustments, changing accessories, or storing power tools. Such preventive safety measures reduce the risk of starting the power tool accidentally.

Store idle power tools out of the reach of children and do not allow persons unfamiliar with the power tool or these instructions to operate the power tool. Power tools are dangerous in the hands of untrained users.

Maintain power tools. Check for misalignment or binding of moving parts, breakage of parts and any other condition that may affect the power tool's operation. If damaged, have the power tool repaired before use. Many accidents are caused by poorly maintained power tools.

Keep cutting tools sharp and clean. Properly maintained cutting tools with sharp cutting edges are less likely to bind and are easier to control.

Use the power tool, accessories, and tool bits etc. in accordance with these instructions, taking into account the working conditions and the work to be performed. Use of the power tool for operations different from those intended could result in a hazardous situation.

Hold power tools by insulated gripping surfaces when performing an operation where cutting tool may contact hidden wiring or its own cord. Contact with a "live" wire will make exposed metal parts of the tool "live" and shock the operator

Service

Have your power tool serviced by a qualified repair person using only identical replacement parts. This will ensure that the safety of the power tool is maintained.

SAVE THESE INSTRUCTIONS FOR REFERENCE

SPECIFIC SAFETY RULES

▲ WARNING: Know your drill. Do not plug the drill into the power source until you have read and understand this Instruction Manual. Learn the tool's applications and limitations, as well as the specific potential hazards related to this tool. Following this rule will reduce the risk of electric shock, fire, or serious injury.



Always wear eye protection. Any power tool can throw foreign objects into your eyes and cause permanent eye damage.

ALWAYS wear safety goggles (not glasses) that comply with ANSI safety standard Z87.1. Everyday glasses have only impact resistant lenses. They ARE NOT safety glasses.

▲ WARNING: Glasses or goggles not in compliance with ANSI Z87.1 could cause serious injury when they break.

▲ WARNING: Always use a safety shield, hearing protection and dust mask when drilling concrete.

Do not drill material too small to be securely held.

Always keep hands out of the path of the drill bit. Avoid awkward hand positions where a sudden slip could cause your hand to move into the path of the drill bit.

Secure the workpiece. Use clamps or a vise to hold the workpiece. It is safer than using your hand and it frees both hands to operate the tool.

Make sure there are no nails or foreign objects in the part of the workpiece to be drilled.

Always remove the plug from the power source before installing or removing a bit or accessory from the chuck.

Do not install or use any drill bit that exceeds 7" (17.5 cm) in length or extends more than 6" (15 cm) beyond the chuck jaws. They can bend or break suddenly.

Always make sure the chuck is tight and the drill bit firmly tightened in the chuck before starting drill.

Before starting the operation, jog the drill switch to make sure the drill bit does not wobble or vibrate.

Do not use fly cutters or multiple-part hole cutters, because they can come apart or become unbalanced during use.

Make sure the spindle has come to a complete stop before touching the chuck or attempting to change the drill bit.

SAVE THESE INSTRUCTIONS FOR REFERENCE

EXTENSION CORD SAFETY

⚠ WARNING: Keep the extension cord clear of the working area. Position the cord so it will not get caught on the workpiece, tools, or any other obstructions while you are working with the power tool.

the same as indicated on the nameplate. Running at lower voltage will damage the motor

Make sure any extension cord used with this tool is in good condition. When using an extension cord, be sure to use one of heavy enough gauge to carry the current the tool will draw. An undersized cord will cause a drop in line voltage resulting in loss of power and overheating.

The table at right shows the correct size to use according to cord length and nameplate ampere rating. If in doubt, use the next heavier gauge. The smaller the gauge number the heavier the cord.

MINIMUM GAUGE (AWG) EXTENSION CORDS (120 V use only)					
Amperage rating		Total length			
More than	Not more than	25' (7.5 m)	50' (15 m)	100' (30m)	150' (45 m)
0	6	18	16	16	14
6	10	18	16	14	12
10	12	16	16	14	12
12	16	14	12	Not Applicable	

Be sure your extension cord is properly wired and in good condition. Always replace a damaged extension cord or have it repaired by a qualified electrician before using it. Protect your extension cord from sharp objects, excessive heat and damp or wet areas.

Use a separate electrical circuit for your power tools. This circuit must not be less than 14-gauge wire and should be protected with either a 15 A time delayed fuse or circuit breaker.

Before connecting the power tool to the power source, make sure the switch is in the OFF position and the power source is

SAVE THESE INSTRUCTIONS FOR REFERENCE

PRODUCT SPECIFICATIONS

PRODUCT SPECIFICATIONS

Rating:	120 V, 60 Hz, AC
Amperes:	10 AMP
Chuck speed:	0-750 RPM (no load)
Chuck:	5/8" Keyed
Weight:	7 lb 12 oz (3.5 kg)

Need Assistance?

Call us on our toll free customer support line:

1-866-349-8665 Monday – Friday from 9am to 5pm















Eastern Standard Time

- Technical questions
- Replacement parts
- Parts missing from package

SAVE THESE INSTRUCTIONS FOR REFERENCE

SYMBOLS

⚠ WARNING: Some of the following symbols may appear on the drill. Study these symbols and learn their meaning. Proper interpretation of these symbols will allow for more efficient and safer operation of this tool.

V	Volts		Three-phase alternating current with neutral
A	Amperes		Read all safety warnings and instructions
Hz	Hertz		Direct current
W	Watts	n_0	No load speed
kW	Kilowatts		Alternating or direct current
μF	Microfarads		Class II construction
L	Litres		Splash-proof construction
kg	Kilograms		Watertight construction
H	Hours		Protective grounding at grounding terminal, Class I tools
N/cm^2	Newtons per square centimetre	.../min	Revolutions or reciprocations per minute
Pa	Pascals	\emptyset	Diameter
OPM	Oscillations per minute	0	Off position
Min	Minutes		Directional Arrow
S	Seconds		Warning symbol
 or a.c.	Alternating current		Wear your safety glasses
	Three-phase alternating current		Wear hearing protection

LISTED



This symbol designates that this tool is listed with Canadian requirements by ETL Testing Laboratories, Inc. Conforms to UL Std. 60745-1 and 60745-2-1.

SAVE THESE INSTRUCTIONS FOR REFERENCE

KNOW YOUR DRILL

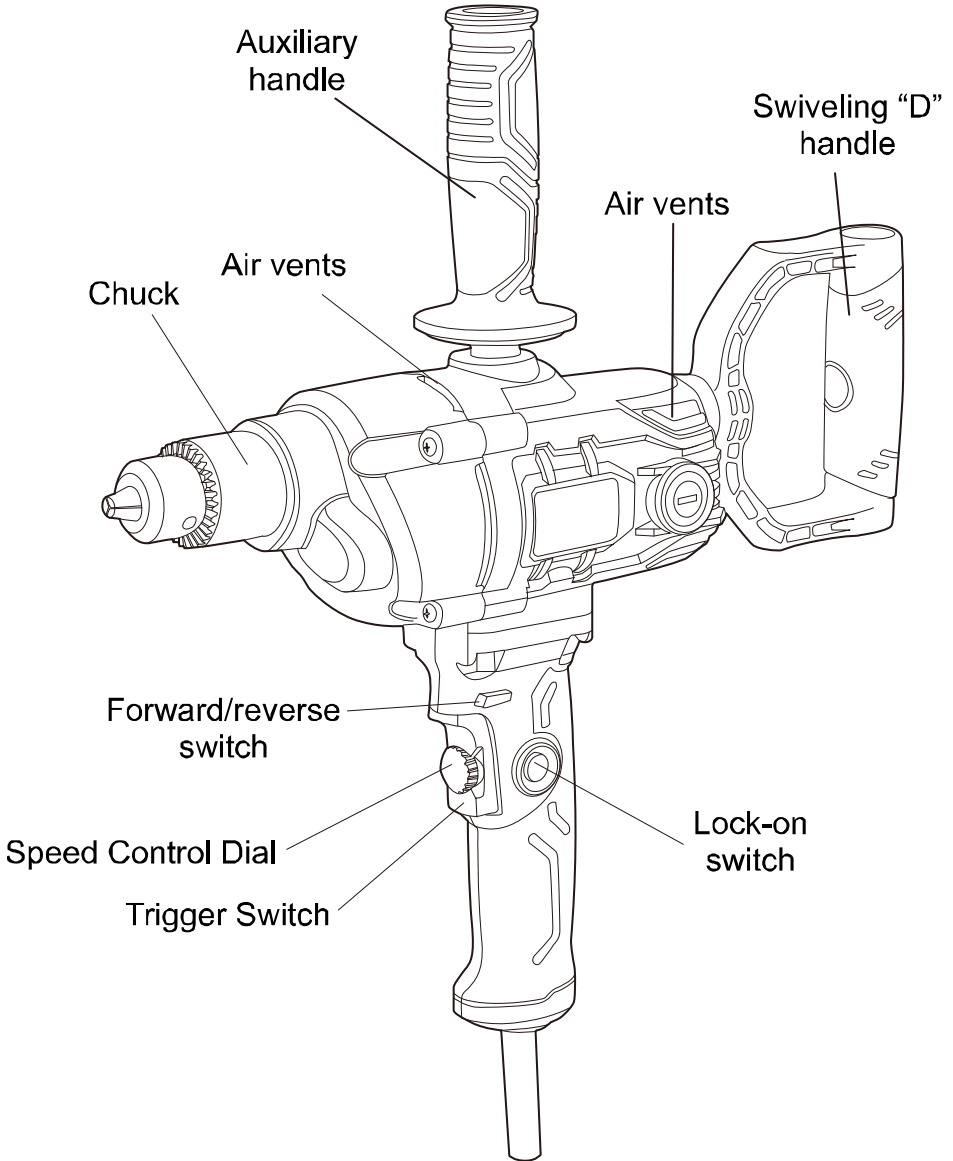

ASSEMBLY AND OPERATING

INSTALLING AUXILIARY HANDLE AND D HANDLE

▲ WARNING: The auxiliary handle and D handle must be installed as it will provide additional control over the drill during heavy drilling operations.

To install the “D” handle (2), insert the “D” Handle (2) into the hole at the back of the drill (1), then insert the screw (3), insert the Allen key (4) into the screw (3), turn it **CLOCKWISE** to tighten it. (Fig. 1).

Fig. 1

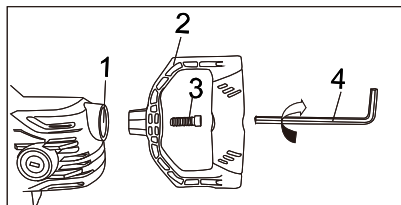

To install the auxiliary handle (1), simply thread it **CLOCKWISE** into the threaded hole (2) in the top of the drill (Fig. 2).

NOTE: Never use a wrench or pliers to tighten the assist handle into the drill. Hand tighten only.

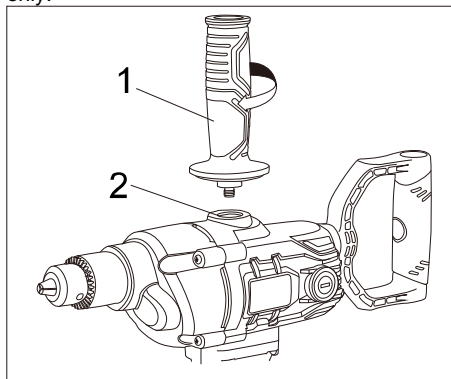

Fig. 2

FORWARD/REVERSE SWITCH

The forward/reverse switch (1) is conveniently mounted immediately above the trigger switch on the drill handle (2) (Fig. 3). To make the drill

rotate clockwise for drilling, push the forward/

reverse switch to the left. To make the drill

rotate counter-clockwise, push the forward/reverse switch to the right.

NOTES:

- Never change the position of the forward/reverse switch while the chuck is turning.
- The trigger switch will **NOT** function with the forward/reverse switch in the middle position or “neutral” position.

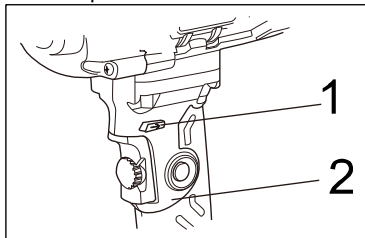

Fig. 3

VARIABLE SPEED TRIGGER AND DIAL

This drill is equipped with a variable-speed ON/OFF trigger switch with speed control dial 1. To start the drill, gently squeeze the trigger switch (3) (Fig. 4).

NOTE: The drill will turn at its slowest speed when the trigger switch is depressed slightly. The drill will turn at its fastest speed when the trigger switch is fully depressed.

2. To stop the drill, release the trigger switch.

NOTE: Drilling at a slow speed for an extended period may cause the switch to overheat. If the drill gets hot, stop drilling and allow it to cool for at least 15 minutes.

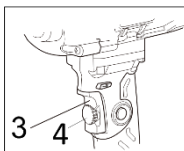

Fig. 4

SPEED CONTROL DIAL

This feature enables you to pre-set the tool for a desired RPM when using the “Lock-On” button feature. The tool speed is adjusted by rotating the “speed control” dial (4) (Fig. 4) clockwise to increase the speed and counter clockwise to decrease the speed. Once you

ASSEMBLY AND OPERATING

have set the speed you desire, when the switch is completely depressed and the “Lock-On” button engaged, the tool speed will change to the speed you dialed in. To Pre-set a desired RPM, pull the switch back completely and engage the “Lock-On” button. Maintain a firm grasp on the running drill with one hand and use your free hand to rotate the “speed control” clockwise or counter-clockwise until the desired drill speed is reached. Then pull the switch back and release it to disengage the “Lock-On” feature. Once you’ve dialed in the desired drill speed, when you start the drill and engage the switch “Lock-On” button the drill will change to the speed you set with the “speed control” dial.

LOCK-ON SWITCH

The lock-on switch is available to hold the ON/OFF switch in the ON position during prolonged operation of the drill. To lock the ON/OFF switch in the ON position:

1. Squeeze the switch trigger (3) (Fig. 5).
2. While squeezing the switch trigger, press the lock-on button (4) into the drill handle (2).
3. While holding the lock-on button into the drill handle release the switch trigger. The drill will continue to run.
4. To turn the drill OFF while the lock-on button is holding the trigger switch ON, squeeze and then release the trigger.

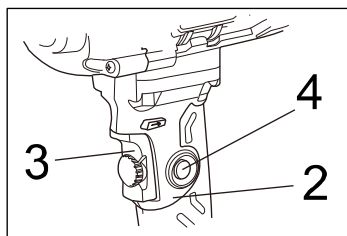

Fig. 5

INSTALLING DRILL BITS

⚠ WARNING: Never hold the chuck body with one hand and use the drill power to rotate the drill body to loosen or tighten bits. Serious injury may result.

1. Remove the drill plug from the power source.
 2. Rotate the chuck collar (1) to open or close the jaws (2) to a point where the opening is slightly larger than the bit size you intend to use (Fig. 6).
 3. Insert the bit into the chuck the full length of the jaws. Raise the front of your drill slightly to prevent the bit from falling out of the chuck jaws.
 4. Insert the chuck key (3) into one of the three holes in the chuck body. Rotate the chuck key clockwise until the drill bit is held firmly in place by the chuck jaws.
- NOTE:** Do not use a wrench on the chuck key. You may damage the key or the chuck.

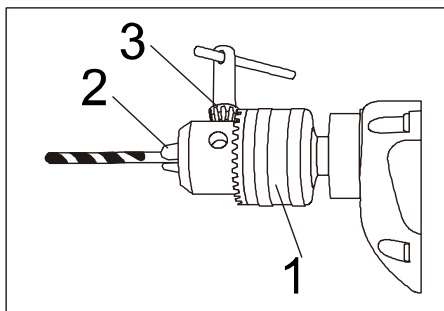

Fig. 6

⚠ WARNING: Do not insert the drill bit into the chuck and tighten as shown in Fig. 7. The drill bit **MUST** be properly inserted with all three chuck jaws holding the bit centered in the chuck. Failure to properly insert the drill bit could cause the drill bit to be thrown from the chuck resulting in possible serious injury or damage to the chuck

ASSEMBLY AND OPERATING

INSTALLING DRILL BITS – cont'd

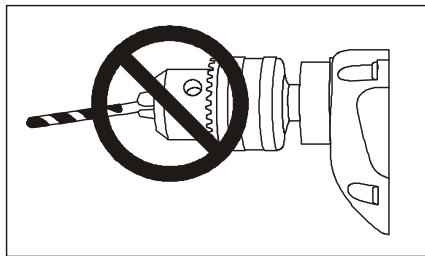

Fig. 7

REMOVING BITS

1. Remove the drill plug from the power source.
2. Insert the chuck key into one of three holes in the chuck body. Rotate chuck key counter-clockwise until the chuck jaws release the drill bit.
NOTE: Do not use a wrench on the chuck key or you may damage the key or chuck.
3. Remove the drill bit.

WARNING

Have you read "GENERAL SAFETY WARNINGS", "POWER TOOL SAFETY WARNINGS", "SPECIFIC SAFETY RULES", "EXTENSION CORD SAFETY" and "SYMBOLS" on pages 3, 4, 5, 6, 7, 8 & 9 of this Instruction Manual? If not, please do it now before you operate this drill. Your safety depends on it!

Every time you use the drill you should verify the following:

1. Chuck is tight.
2. Workpiece is properly secured.
3. Safety glasses are being worn.

Failure to adhere to these safety rules can greatly increase the chances of injury.

DRILLING

When drilling in smooth hard surfaces such as metal, use a center punch to mark the desired hole location. This will prevent the drill bit from slipping off center as the hole is started. The workpiece to be drilled should be secured in a vice or with clamps to keep it from turning as the drill bit rotates (Fig. 8).

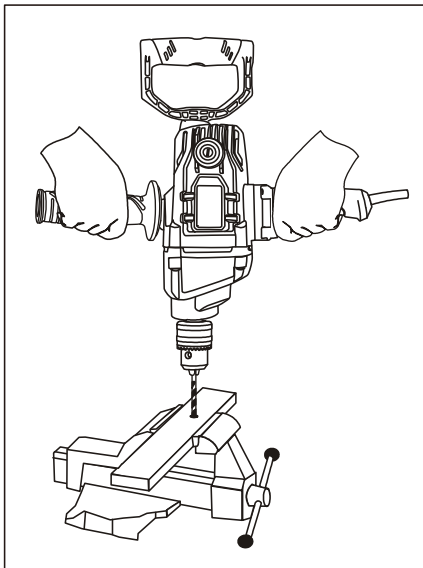

Fig. 8

1. Check the drill bit to make sure it is firmly locked into the drill chuck and the forward/reverse switch is in the forward position.
2. Hold the drill firmly with both hands. Use your left hand to grasp the main handle and switch and your right hand to grasp the auxiliary handle (Fig. 8). If the auxiliary handle cannot be used due to inadequate space, use your right hand to grasp the swivelling "D" handle (Fig. 9).
3. While holding the drill firmly, place the point of the drill bit at the point to be drilled. Squeeze the switch trigger to start the drill.

NOTE: Always use a higher drill speed when drilling small holes. Use a slower drill speed when drilling large holes.

ASSEMBLY AND OPERATING

DRILLING – cont'd

4. Move the drill bit into the workpiece applying only enough pressure to keep the bit cutting. Do not force the drill bit or apply sideways pressure to elongate the hole.

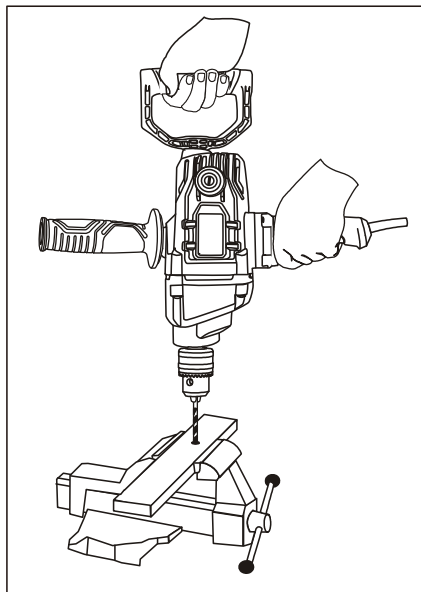

Fig. 9

⚠ WARNING: Be prepared for binding and bit breakthrough. When these situations occur, the drill bit has a tendency to grab the workpiece. This action will kick the drill opposite to the direction of the drill bit rotation and could cause loss of control when breaking through material as you complete drilling the hole. If you are not prepared, this loss of control can result in possible serious injury.

When drilling metals, use a light oil on the drill bit to keep it from overheating. The oil will prolong the life of the drill bit and improve the drill cutting action. If the bit jams in the workpiece or if the drill stalls, release the switch trigger immediately. Remove the bit from the

workpiece and determine the reason for jamming.

DRIVING SCREWS

When driving screws, care must be taken to use the bit that correctly fits the screw being driven. Make sure you use the largest bit size that will properly fit into the head of the screw.

1. Select the correct screwdriver bit for the screw being driven.
2. Fasten the screwdriver bit into the chuck, making sure the flats of the bit are gripped by the chuck jaws.

NOTES:

- a) If the material is particularly soft or porous, run the drill at slower speeds to avoid over-driving the screw.
- b) Hold the drill firmly with both hands while driving screws to avoid loss of control.

CHUCK REMOVAL

The drill chuck must be removed in order to use some accessories. To remove the chuck:

1. Remove the drill plug from the power source.
2. Insert a 5/16" or larger hex key (1) into the chuck (2) and tighten the chuck jaws securely. Make sure each of the three chuck jaws (3) is seated on the flat surfaces of the hex key (Fig. 10).
3. Tap the hex key sharply with a mallet (4) in a CLOCKWISE direction. This action will loosen the screw in the chuck for easy removal.

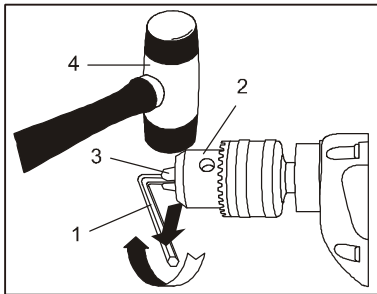



Fig.10

CHUCK REMOVAL – cont'd

4. Open the chuck jaws and remove the hex key.
5. Open the chuck jaws as far as possible.
6. Remove the chuck screw using a  #2 screwdriver (Fig. 11).
NOTE: Turn screw **CLOCKWISE** to remove it. This screw has a left-hand thread.

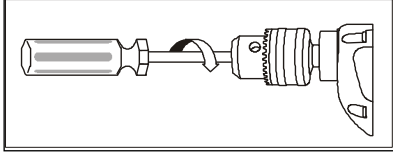

Fig.11

7. Insert the hex key into the chuck and tighten the jaws of the chuck securely (Fig. 12). Tap the hex key sharply with a mallet in a **COUNTER-CLOCKWISE** direction. This will loosen the chuck on the spindle. The chuck can now be unscrewed and removed from the spindle by hand.

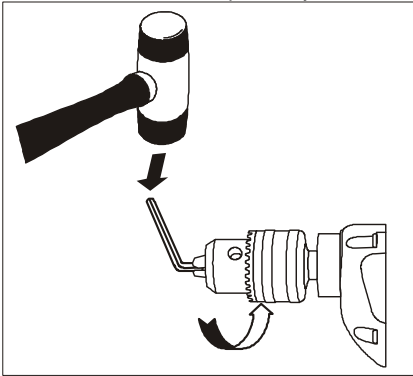



Fig.12

RETIGHTENING A LOOSE CHUCK

After installing the chuck once it has been removed, the chuck may become loose on the spindle and develop a wobble. Also, the chuck screw may become loose, causing the chuck jaws to bind and prevent them from closing. To tighten the chuck, follow these steps:

1. Insert the hex key into the chuck and tighten the chuck securely.
2. Tap the hex key sharply with a mallet in a **CLOCKWISE** direction (Fig. 9). This will tighten the chuck on the spindle.
3. Open the chuck jaws and remove the hex key.
4. Tighten the chuck screw using a  #2 screwdriver.
NOTE: Turn the screw **COUNTER-CLOCKWISE** to tighten it. This screw has a left hand thread.

REPLACING CARBON MOTOR BRUSHES

The carbon motor brushes will wear down and require replacing. The time intervals between replacements will vary depending upon the working environment and the hours of use. It is recommended that the brushes be checked after each 10 hours of use. When the length of the carbon brush reaches 1/4" (6.35 mm), the brushes should be replaced.

▲ WARNING: Unplug the tool from the power source.

1. Use a 3/16" (5 mm) slot screwdriver and remove one brush cap (1) (fig. 13). Turn the brush cap counter-clockwise to remove it from the motor housing.
 2. Pull the spring & brush assembly (2) from the brush holder (3) in the motor housing (4).
 3. Insert the new spring & brush assembly into the motor housing.
 4. Compress the spring into the brush holder and thread the brush cap back into the motor housing.
- NOTE: Make sure the brush cap threads are not cross-threaded. Do NOT over tighten.

5. Repeat steps 1 to 4 to replace the second carbon brush located on the opposite side of the motor housing.

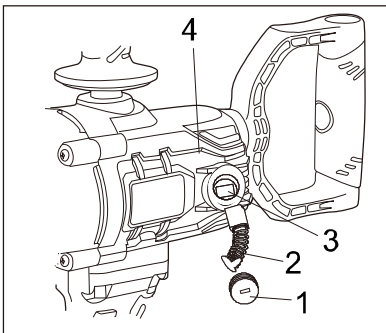

Fig.13

GENERAL MAINTENANCE

▲ WARNING: When servicing, use only identical replacement parts. The use of any other part may create a hazard or cause product damage.

DO NOT use solvents when cleaning plastic parts. Plastics are susceptible to damage from various types of commercial solvents and may be damaged by their use. Use a clean cloth to remove dirt, dust, oil, grease etc.

▲ WARNING: Do not allow brake fluids, gasoline, petroleum-based products, penetrating oils, etc. to come into contact with plastic parts. They contain chemicals that can damage, weaken or destroy plastic.

DO NOT abuse power tools. Abusive practices can damage the tool and the workpiece.

▲ WARNING: DO NOT attempt to modify tools or create accessories. Any such alteration or modification is misuse and could result in a hazardous condition leading to possible serious injury. It will also void the warranty.

LUBRICATION

All of the bearings in this tool are lubricated with a sufficient amount of high-grade lubricant for the life of the unit under normal conditions. Therefore, no further lubrication is required.

EXPLODED VIEW

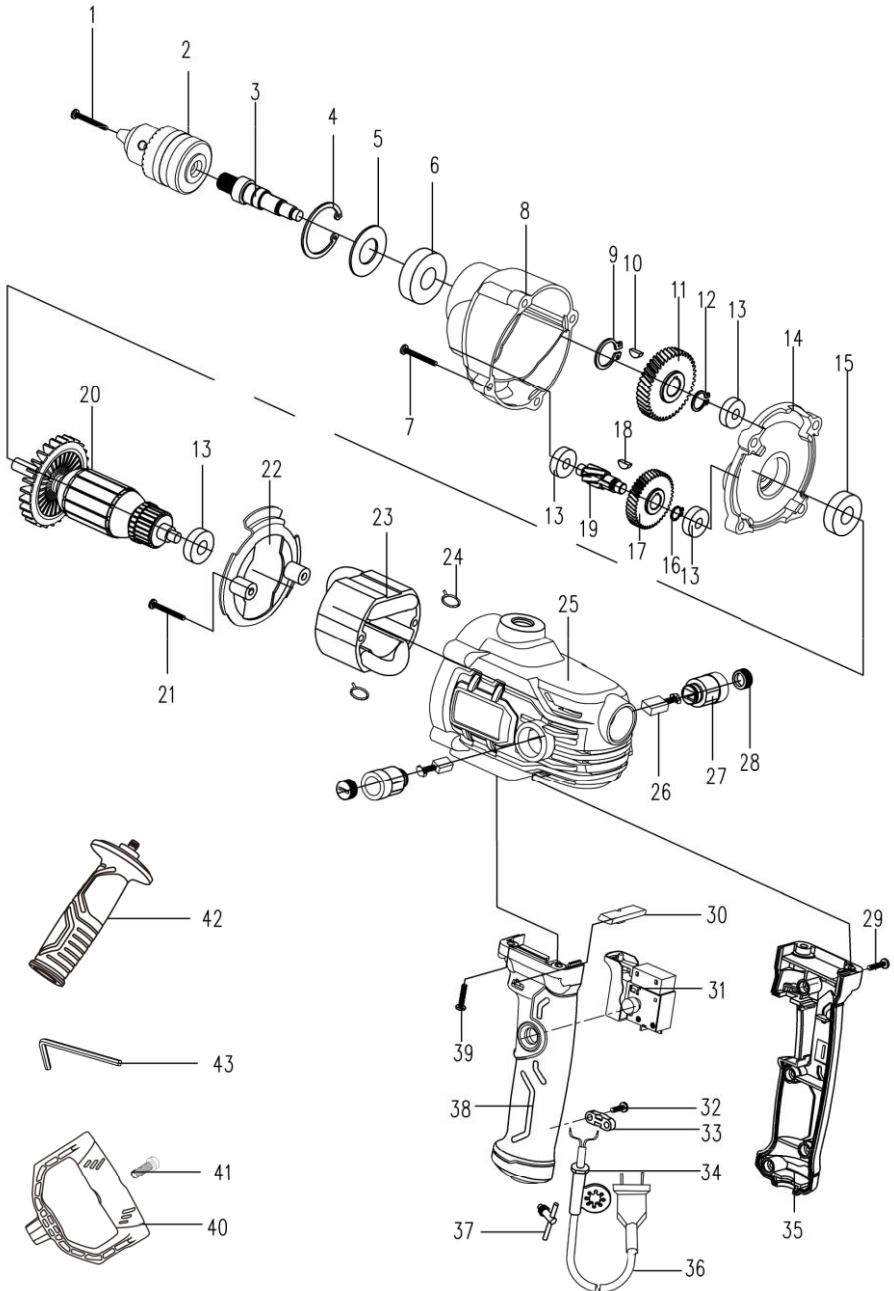

PARTS LIST

▲ WARNING: When servicing, use only original equipment replacement parts. The use of any other parts may create a safety hazard or cause damage to the drill. Any attempt to repair or replace electrical parts on this saw may create a safety hazard unless repairs are performed by a qualified technician. For more information, call the Toll-free Helpline, at 1-866-349-8665. Monday to Friday 9-5 EST.

Always order by PART NUMBER, not by key number.

Key#	Part #	Part Name	QTY
1	241-0725-1	Screw M6X25(Left)	1
2	241-0725-2	Chuck	1
3	241-0725-3	Spindle	1
4	241-0725-4	Circlip for hole 40	1
5	241-0725-5	Dust ring	1
6	241-0725-6	Ball Bearing 6203	1
7	241-0725-7	Screw ST5X35	4
8	241-0725-8	Gear box	1
9	241-0725-9	Circlip forshaft 17	1
10	241-0725-10	key 4X5X13	1
11	241-0725-11	Big Gear	1
12	241-0725-12	Circlip forshaft 14	1
13	241-0725-13	Ball Bearing 608	4
14	241-0725-14	Gearbox cover	1
15	241-0725-15	Ball Bearing 6200	1
16	241-0725-16	Shaft bezels 10	1
17	241-0725-17	Medinum gear	1
18	241-0725-18	key 3X3.7X13	1
19	241-0725-19	Gear shaft	1
20	241-0725-20	Armature	1
21	241-0725-21	Screw ST5X60	2
22	241-0725-22	Wind ring	1
23	241-0725-23	Stator	1

PARTS LIST

Key#	Part #	Part Name	QTY
24	241-0725-24	Pull Reed	2
25	241-0725-25	Housing	1
26	241-0725-26	Carbon Brush	2
27	241-0725-27	Brush Holder	2
28	241-0725-28	Brush Cap	2
29	241-0725-29	Screw ST4X16	4
30	241-0725-30	Switch pusher	1
31	241-0725-31	Switch	1
32	241-0725-32	Screw ST4X14	1
33	241-0725-33	Cord Clip	1
34	241-0725-34	Cord sleeve	1
35	241-0725-35	Right handle	1
36	241-0725-36	Power Cord	1
37	241-0725-37	Chuck Key	1
38	241-0725-38	Left handle	1
39	241-0725-39	Screw ST5X18	4
40	241-0725-40	Rear handle	1
41	241-0725-41	Screw M8X25	1
42	241-0725-42	Side handle	1
43	241-0725-43	Inner hex wrench M6X120	1



MASTERFORCE® 5/8" DRILL/MIXER WARRANTY

90-DAY MONEY BACK GUARANTEE:

This MASTERFORCE® brand power tool carries our 90-Day Money Back Guarantee. If you are not completely satisfied with your MASTERFORCE® brand power tool for any reason within ninety (90) days from the date of purchase, return the tool with your original receipt to any MENARDS® retail store, and we will provide you a refund – no questions asked.

3-YEAR LIMITED WARRANTY:

This MASTERFORCE® brand power tool carries our famous No Hassle 3-Year Limited Warranty to the original purchaser. If, during normal use, this MASTERFORCE® power tool breaks or fails due to a defect in material or workmanship within three (3) years from the date of original purchase, simply bring the tool with the original sales receipt back to your nearest MENARDS® retail store. At its discretion, MASTERFORCE® agrees to have the tool or any defective part(s) repaired or replaced with the same or similar MASTERFORCE® product or part free of charge, within the stated warranty period, when returned by the original purchaser with original sales receipt. Notwithstanding the foregoing, this limited warranty does not cover any damage that has resulted from abuse or misuse of the Merchandise. This warranty: (1) excludes expendable parts including but not limited to blades, brushes, belts, bits, light bulbs, and/or batteries; (2) shall be void if this tool is used for commercial and/or rental purposes; and (3) does not cover any losses, injuries to persons/property or costs. This warranty does give you specific legal rights and you may have other rights, which vary from state to state. Be careful, tools are dangerous if improperly used or maintained. Seller's employees are not qualified to advise you on the use of this Merchandise. Any oral representation(s) made will not be binding on seller or its employees. The rights under this limited warranty are to the original purchaser of the Merchandise and may not be transferred to any subsequent owner. This limited warranty is in lieu of all warranties, expressed or implied including warranties or merchantability and fitness for a particular purpose. Seller shall not be liable for any special, incidental, or consequential damages. The sole exclusive remedy against the seller will be for the replacement of any defects as provided herein, as long as the seller is willing or able to replace this product or is willing to refund the purchase price as provided above. For insurance purposes seller is not allowed to demonstrate any of these power tools for you.

For questions / comments, technical assistance or repair parts –
Please call toll free at: 1-866-349-8665 (M-F 9am – 5pm).

**SAVE YOUR RECEIPTS
THIS WARRANTY IS VOID WITHOUT THEM**

MASTER FORCE[®]

MENARDS[®]

© 2016 Menard, Inc., Eau Claire, WI 54703