

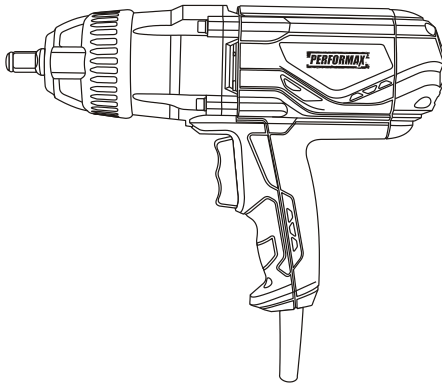

8.5A IMPACT WRENCH

241-9891

Owner's Manual



PRODUCT SPECIFICATIONS

Rating:	120 V AC, 60 Hz
Amperes:	8.5 A
Speed:	2,600 RPM (no load)
Impact speed:	2,700 BPM
Torque:	440 ft/lbs in reverse 320 ft/lbs in forward
Square drive:	1/2"
Weight:	9 lb 8 oz (4.3 kg)

Need Assistance?

Call us on our toll free customer support line:
1-866-349-8665

- Technical questions
- Replacement parts
- Parts missing from package

TABLE OF CONTENTS

Product specifications	1
Table of contents	2
General safety warnings	3–4
Eye, ear & lung protection	3–4
Electrical safety	4
Power tool safety	5–6
General safety rules	5
Work area safety	5
Electrical safety	5
Personal safety	5–6
Power tool use and care	6
Service	6
Specific safety rules	7
Extension cord safety	8
Symbols	9
Know your impact wrench	10
Accessories	10
Assembly and operation	11–13
Installing impact sockets	11
Forward/reverse trigger switch	11
Removing fasteners	11–12
Tightening wheel nuts	12–13
Maintenance	14–15
Removing motor brushes	14–15
Installing new motor brushes	15
Exploded view	16
Parts list	17–18
Warranty	19

GENERAL SAFETY WARNINGS



WARNING: Before using this tool or any of its accessories, read this manual and follow all Safety Rules and Operating Instructions. The important precautions, safeguards and instructions appearing in this manual are not meant to cover all possible situations. It must be understood that common sense and caution are factors which cannot be built into the product.

This instruction manual includes the following:

- General Safety Rules
- Specific Safety Rules and Symbols
- Functional Description
- Assembly
- Operation
- Maintenance
- Accessories

EYE, EAR & LUNG PROTECTION



ALWAYS WEAR EYE PROTECTION THAT CONFORMS WITH CSA REQUIREMENTS or ANSI SAFETY STANDARD Z87.1

FLYING DEBRIS can cause permanent eye damage. Prescription eyeglasses ARE NOT a replacement for proper eye protection.



WARNING: Non-compliant eyewear can cause serious injury if broken during operation of a power tool.



WARNING: Use hearing protection, particularly during extended periods of operation of the tool or if the operation is noisy.

SAVE THESE INSTRUCTIONS FOR REFERENCE

GENERAL SAFETY WARNINGS



WEAR A DUST MASK THAT IS DESIGNED TO BE USED WHEN OPERATING A POWER TOOL IN A DUSTY ENVIRONMENT.



WARNING: Dust that is created by power sanding, sawing, grinding, drilling, and other construction activities may contain chemicals that are known to cause cancer, birth defects, or other genetic abnormalities. These chemicals include:

Lead from lead-based paints

Crystalline silica from bricks, cement, and other masonry products

Arsenic and chromium from chemically-treated lumber

The level of risk from exposure to these chemicals varies according to how often this type of work is performed. In order to reduce exposure to these chemicals, work in a well-ventilated area, and use approved safety equipment, such as a dust mask that is specifically designed to filter out microscopic particles.

ELECTRICAL SAFETY



WARNING: To avoid electrical hazards, fire hazards or damage to the tool, use proper circuit protection.

This tool is wired at the factory for 120 V operation. It must be connected to a 120 V 15 A time delayed fuse or circuit breaker. To avoid shock or fire, replace power cord immediately if it is worn, cut or damaged in any way.

SAVE THESE INSTRUCTIONS FOR REFERENCE

POWER TOOL SAFETY

▲ WARNING: Read all safety warnings and instructions. Failure to follow the warnings and instructions may result in electric shock, fire and/or serious injury.

Save all warnings and instructions for future reference.

Work area safety

Keep work area clean and well lit. Cluttered or dark areas invite accidents.

Do not operate power tools in explosive atmospheres, such as in the presence of flammable liquids, gases or dust. Power tools create sparks which may ignite the dust or fumes.

Keep children and bystanders away while operating a power tool. Distractions can cause you to lose control.

Electrical safety

Power tool plugs must match the outlet. Never modify the plug in any way. Do not use any adapter plugs with earthed (grounded) power tools. Unmodified plugs and matching outlets will reduce risk of electric shock.

Avoid body contact with earthed or grounded surfaces such as pipes, radiators, ranges and refrigerators. There is an increased risk of electric shock if your body is earthed or grounded.

Do not expose power tools to rain or wet conditions. Water entering a power tool will increase the risk of electric shock.

Do not abuse the cord. Never use the cord for carrying, pulling or unplugging the power tool. Keep cord away from heat, oil, sharp edges or moving parts. Damaged or entangled cords increase the risk of electric shock.

When operating a power tool outdoors, use an extension cord suitable for outdoor use. Use of a cord suitable for outdoor use reduces the risk of electric shock.

If operating a power tool in a damp location is unavoidable, use a residual current device (RCD) protected supply. Use of a ground fault circuit interrupter (GFCI) reduces the risk of electric shock.

Personal safety

Stay alert, watch what you are doing and use common sense when operating a power tool. Do not use a power tool while you are tired or under the influence of drugs, alcohol or medication. A moment of inattention while operating power tools may result in serious personal injury.

Use personal protective equipment. Always wear eye protection. Protective equipment such as dust mask, non-skid safety shoes, hard hat, or hearing protection used for appropriate conditions will reduce personal injuries.

Prevent unintentional starting. Ensure the switch is in the off-position before connecting to power source and/or battery pack, picking up or carrying the tool. Carrying power tools with your finger on the switch or energizing power tools that have the switch on invites accidents.

Remove any adjusting key or wrench before turning the power tool on. A wrench or a key left attached to a rotating part of the power tool may result in personal injury.

Do not overreach. Keep proper footing and balance at all times. This enables better control of the power tool in unexpected situations.

Dress properly. Do not wear loose clothing or jewelry. Keep your hair, clothing and gloves away from moving parts. Loose clothes, jewelry or long hair can be caught in moving parts.

SAVE THESE INSTRUCTIONS FOR REFERENCE

POWER TOOL SAFETY

Personal safety – cont'd

If devices are provided for the connection of dust extraction and collection facilities, ensure these are connected and properly used. Use of dust collection can reduce dust-related hazards.

Power tool use and care

Do not force the power tool. Use the correct power tool for your application. The correct power tool will do the job better and safer at the rate for which it was designed.

Do not use the power tool if the switch does not turn it on and off. Any power tool that cannot be controlled with the switch is dangerous and must be repaired.

Disconnect the plug from the power source and/or the battery pack from the power tool before making any adjustments, changing accessories, or storing power tools. Such preventive safety measures reduce the risk of starting the power tool accidentally.

Store idle power tools out of the reach of children and do not allow persons unfamiliar with the power tool or these instructions to operate the power tool. Power tools are dangerous in the hands of untrained users.

Maintain power tools. Check for misalignment or binding of moving parts, breakage of parts and any other condition that may affect the power tool's operation. If damaged, have the power tool repaired before use. Many accidents are caused by poorly maintained power tools.

Keep cutting tools sharp and clean. Properly maintained cutting tools with sharp cutting edges are less likely to bind and are easier to control.

Use the power tool, accessories and tool bits etc. in accordance with these instructions, taking into account the working conditions and the work to be performed. Use of the power tool for operations different from those intended could result in a hazardous situation.

Hold power tool by insulated gripping surfaces when performing an operation where the cutting tool may contact hidden wiring or its own cord. Contact with a "live" wire will make exposed metal parts of the tool "live" and shock the operator.

Use clamps or another practical way to secure and support the workpiece to a stable platform. Holding the work by hand or against your body leaves it unstable and may lead to loss of control.

Service

Have your power tool serviced by a qualified repair person using only identical replacement parts. This will ensure that the safety of the power tool is maintained.

SAVE THESE INSTRUCTIONS FOR REFERENCE

SPECIFIC SAFETY RULES

▲ WARNING: Know your impact wrench. Read the Owner's Manual carefully. Learn the tool's applications and limitations, as well as the specific potential hazards related to this tool. Following this rule will reduce the risk of electric shock, fire or serious injury.



Always wear eye protection. Any power tool can throw foreign objects into your eyes and cause permanent eye damage.

ALWAYS wear safety goggles (not glasses) that comply with ANSI safety standard Z87.1. Everyday glasses have only impact resistant lenses. They ARE NOT safety glasses.

▲ WARNING: Glasses or goggles not in compliance with ANSI Z87.1 could cause serious injury when they break.

Always use hearing protection when operating the impact wrench.

Hold power tool by insulated gripping surfaces, when performing an operation where the fastener may contact hidden wiring or its own cord. Fasteners contacting a "live" wire may make exposed metal parts of the power tool "live" and could give the operator an electric shock.

Use only impact sockets and accessories that are designed for use with an impact wrench. Do not use chrome plated sockets and accessories. Chrome plated sockets and accessories are designed for hand use only and MUST NOT be used with an impact wrench. They may shatter and possibly cause serious injury.

Before each use, check the impact sockets and accessories for excessive wear or cracks. Worn or damaged sockets or accessories may shatter and possibly cause serious injury. Worn accessories may allow the socket to come off during operation of the impact wrench.

Never use the impact wrench as a torque wrench. Always use a torque wrench to adjust the fastener to the specified torque.

Keep the impact wrench handle and body clean and free of oil and grease. Always use a clean dry cloth when cleaning. Do not use solvents, brake fluid, gasoline or other petroleum products to clean the tool. They will damage the tool.

Do not wear neckties or loose clothing.

When wearing gloves, they must be tight fitting and slip resistant type. Leather gloves offer the best protection.

Always use two hands when operating the impact wrench. Use one hand on the handle and the other on the front of the tool body.

Never place your hand so it is touching the socket or accessory when the tool is turned ON. Your hand could be seriously injured.

Always remove the plug from the power source before installing or removing any socket or accessory.

Be ready for components to shift when removing any fastener. The speed of the fastener removal could cause unexpected shifting of the components.

SAVE THESE INSTRUCTIONS FOR REFERENCE

EXTENSION CORD SAFETY

⚠ WARNING: Keep the extension cord clear of the work area. Position the cord so that it will not get caught on the workpiece, a tool, or any other obstruction while the power tool is in use.

If an extension cord is used with this impact wrench, verify that it is in good condition. When using an extension cord, be sure to use one that is heavy enough to carry the current that the tool will draw. An undersized cord will cause a drop in line voltage, which will result in a loss of power and overheating.

The following table shows the correct size to use according to cord length and the amperage rating that is listed on the tool's nameplate. When in doubt, use the next heavier gauge. The smaller the gauge number, the heavier the cord.

Verify that the extension cord is properly wired and in good condition. Replace a damaged extension cord immediately, or have it repaired by a qualified electrician before using it. Keep the extension cord away from sharp objects, excessive heat, and damp or wet areas.



Use a separate electrical circuit for power tools. This circuit must consist of not less than 14 gauge wire, and should be protected by either a 15 Amp. time-delayed fuse or a circuit breaker. Before connecting the power tool to the outlet, verify that the switch is in the OFF position, and that the voltage of the power source is the same as the voltage that is indicated on the tool's nameplate. Running this impact wrench at lower voltage will damage the motor.









MINIMUM GAUGE (AWG) EXTENSION CORDS (120 V use only)					
Amperage rating		Total length			
More than	Not more than	25' (7.5 m)	50' (15 m)	100' (30 m)	150' (45 m)
0	6	18	16	16	14
6	10	18	16	14	12
10	12	16	16	14	12
12	16	14	12	Not Applicable	

SAVE THESE INSTRUCTIONS FOR REFERENCE

SYMBOLS

⚠ WARNING: Some of the following symbols may appear on the impact wrench. Study these symbols and learn their meaning. Proper interpretation of these symbols will allow for more efficient and safer operation of this tool.

V	Volts
A	Amperes
Hz	Hertz
W	Watts
kW	Kilowatts
μF	Microfarads
L	Litres
kg	Kilograms
H	Hours
N/cm²	Newtons per square centimeter
Pa	Pascals
Min	Minutes
S	Seconds
	Alternating current
	Three-phase alternating current
	Three-phase alternating current with neutral

	Direct current
n₀	No load speed
	Alternating or direct current
	Class II construction
	Splash-proof construction
	Watertight construction
	Protective grounding at grounding terminal, Class I tools
.../min	Revolutions or reciprocations per minute
∅	Diameter
0	Off position
	Directional arrow
	Warning symbol



This symbol designates that this tool is listed with U.S. requirements by ETL Testing Laboratories, Inc.
 Conforms to UL Std. 60745-1, 60745-2-2.
 Certified to CAN/CSA STD C22.2 No. 60745-1, 60745-2-2.

KNOW YOUR IMPACT WRENCH

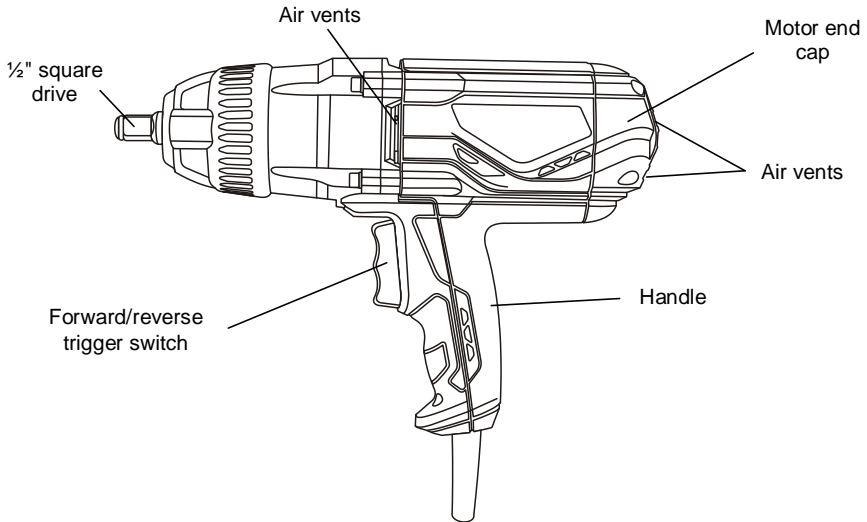

ACCESSORIES

AVAILABLE ACCESSORIES

⚠ WARNING: Use only accessories that are recommended for this impact wrench. Follow the instructions that accompany the accessories. The use of improper accessories may result in injury to the operator or damage to the impact wrench.

Before using any accessory, carefully read the instructions or the owner's manual for the accessory.

- Impact sockets
- Impact extensions
- Impact adapters
- Impact nut drivers
- Impact screwdriver bits

⚠ WARNING: If any part is missing or damaged, do not plug the impact wrench into the power source until the missing or damaged part is replaced.

ASSEMBLY AND OPERATION

INSTALLING IMPACT SOCKETS

⚠ WARNING: Use only impact sockets and accessories that are designed for use with an impact wrench. Do not use chrome plated sockets and accessories. Chrome plated sockets and accessories are designed for hand use only and **MUST NOT** be used with an impact wrench. They may shatter and possibly cause serious injury.

⚠ WARNING: Always remove the plug from the power source before changing any sockets or accessories. You may injure your hand if the tool is started accidentally.

To install a socket, press the square portion of the socket (1) onto the square drive (2) of the impact wrench (Fig. 1).

NOTE: Slide the socket fully onto the square drive so the socket is held firmly in place.

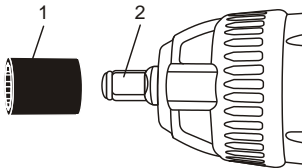

Fig. 1

FORWARD/REVERSE TRIGGER SWITCH

This impact wrench is equipped with a rocker style forward/reverse switch (1) (Fig. 2).

1. To operate the impact wrench in the forward direction, press and hold the bottom part of the switch (2). The socket will rotate in a clockwise direction to **tighten** the fastener.
2. To operate the impact wrench in the reverse direction, press and hold the top part of the switch (3). The socket will rotate in a counter clockwise direction to loosen the fastener.

⚠ WARNING

For safety reasons, the operator must read the sections of this Owner's Manual entitled "GENERAL SAFETY WARNINGS", "POWER TOOL SAFETY", "SPECIFIC SAFETY RULES", "EXTENSION CORD SAFETY" and "SYMBOLS" before using this impact wrench.

Verify the following every time the impact wrench is used:

1. Safety glasses and hearing protection are being worn.
2. Socket or accessory is "impact wrench" rated.
3. Socket or accessory is in good condition.

Failure to observe these safety rules will significantly increase the risk of injury.

REMOVING FASTENERS

One of the most common uses for the impact wrench is to remove car wheel nuts for rotating the tires. Car wheel nut removal is used for illustrative purposes.

⚠ DANGER: Before attempting to remove a car wheel, make sure all jacking, wheel blocking and wheel removal safety procedures illustrated in the Owner's Manual for your car are followed exactly. Failure to follow those safety instructions could result in serious injury or death.

1. Install the correct size of impact socket on the impact wrench as outlined in Fig. 1
2. Plug the impact wrench power cord into an appropriate power source.
3. Grasp the impact wrench handle (1) with one hand and the front housing of the impact wrench (2) with the other hand (Fig. 2).

ASSEMBLY AND OPERATION

REMOVING FASTENERS – cont'd

- Place impact socket (3) onto the wheel nut.

NOTE: Make sure the socket is fully engaged with the nut to avoid potentially damaging the socket or the wheel nut.

- While holding the tool level with the ground and with a firm grasp, squeeze the **upper portion** of the trigger switch (4).

When removing fasteners, do not operate the impact wrench for more than 15 seconds unless the fastener begins to turn. If the fastener fails to turn within 15 seconds, reverse the direction of rotation and operate the impact wrench in a forward direction on the fastener for a few seconds. Now switch back to reverse direction and remove the fastener. This procedure will usually break loose seized or “frozen” fasteners.

▲ WARNING: Operating the impact wrench for more than 15 seconds at a time on a seized or “frozen” fastener will place severe stress on the impact wrench and cause damage. It may also break the fastener.

NOTE: Once the wheel nut has been removed, release the trigger switch. The tool will turn OFF.

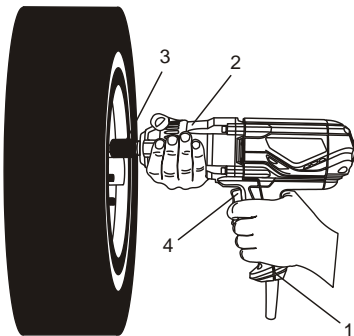

Fig. 2

TIGHTENING WHEEL NUTS

This impact wrench can be used to tighten wheel nuts and other fasteners.

- Install the correct size of impact socket on the impact wrench (Fig. 1).
- Place the wheel on the wheel studs and thread one wheel nut (1) clockwise onto each wheel stud (Fig. 3).

NOTE: Thread each wheel nut at least three full turns onto the wheel stud by hand to make sure the nuts are NOT cross threaded. The wheel stud and wheel nut will be damaged if the nut is cross threaded.

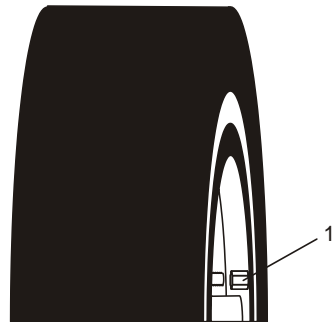

Fig. 3

- Grasp the impact wrench handle with one hand and the front housing of the impact wrench with the other hand.
- Place the impact socket onto the lower wheel nut (1) (Fig. 4 & 5).

NOTE: Make sure the socket is fully engaged with the nut to avoid potentially damaging the socket or the wheel nut.

- While holding the tool level with the ground and with a firm grasp, squeeze the **lower portion** of the trigger switch. The impact wrench will tighten the wheel nut.

ASSEMBLY AND OPERATION

TIGHTENING WHEEL NUTS – cont'd

NOTE: Release the trigger switch IMMEDIATELY when the impact mechanism "rattles".

6. Proceed with tightening the remaining wheel nuts as noted above.

⚠ WARNING: Tighten the wheel nuts in the sequence outlined in Fig. 4 for 4 stud wheel patterns and Fig. 5 for 5 stud wheel patterns. Following this sequence is extremely important to avoid potential distortion of the brake rotors or drums.

7. Use a torque wrench to tighten all wheel nuts to the manufacturer's recommended torque. Follow the same tightening sequence as noted above.
8. Once the wheel nuts have been tightened, lower the vehicle so the wheel is firmly in contact with the ground and verify the torque of each wheel nut using a conventional torque wrench.

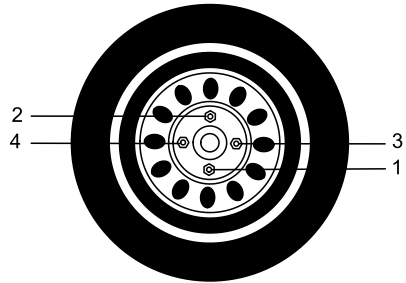

Fig. 4

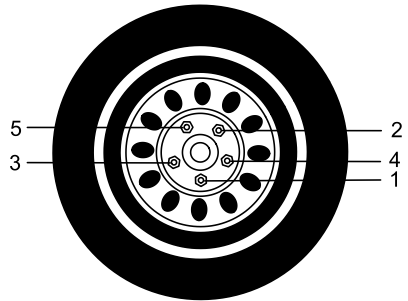

Fig. 5

MAINTENANCE

GENERAL

⚠ WARNING: When servicing, use only identical replacement parts. Use of any other part may create a hazard or cause product damage.

DO NOT use solvents when cleaning plastic parts. Plastics are susceptible to damage from various types of commercial solvents and may be damaged by their use. Use a clean cloth to remove dirt, dust, oil, grease etc.

⚠ WARNING: Do not at any time allow brake fluids, gasoline, petroleum-based products, penetrating oils, etc. to come into contact with plastic parts. They contain chemicals that can damage, weaken or destroy plastic.

DO NOT abuse power tools. Abusive practices can damage the tool as well as the workpiece.

⚠ WARNING: DO NOT attempt to modify tools or create accessories. Any such alteration or modification is misuse and could result in a hazardous condition leading to possible serious injury. It will also void the warranty.

LUBRICATION

All of the bearings in this tool are lubricated with a sufficient amount of high-grade lubricant for the life of the unit under normal conditions. Therefore, no further lubrication is required.

REMOVING MOTOR BRUSHES

Motor brushes are a normal wear item and will require replacing periodically depending upon the amount the tool is used. The following information outlines the general procedure for removal of the worn brushes and installation of the new brushes.

⚠ WARNING: Make sure the impact wrench is unplugged from the power source.

Removing worn brushes

1. Remove 4 screws (1) from the motor end cap (2) using a #2 \oplus screwdriver (Fig. 6).

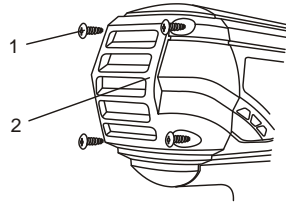

Fig. 6

2. Carefully pry the motor end cap (2) off the motor housing (3) using a small slot screwdriver.

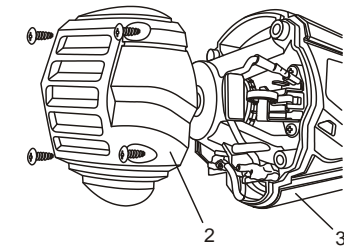

Fig. 7

MAINTENANCE

Removing worn brushes – cont'd

NOTE: Pay attention to the position of the braided copper brush wire (8) (Fig. 8). When the new carbon brush is reinstalled, the braided brush wire **MUST** be placed in exactly the same position.

3. Use a small slot screwdriver to lift the end of the coil spring (4) upward and place it on the edge of the copper brush holder (5).
4. Use small needle nose pliers to pull the top spade connector (6) from the spade terminal.
5. Turn the two brush holder screws (7) counter clockwise about 4 turns using a #2 \oplus screwdriver.
NOTE: Do NOT completely remove the screws. Back the screws out only far enough to allow the carbon brush to be removed from the brush holder.
6. Carefully grasp the braided copper brush wire (8) and lift the carbon brush (9) from the brush holder.

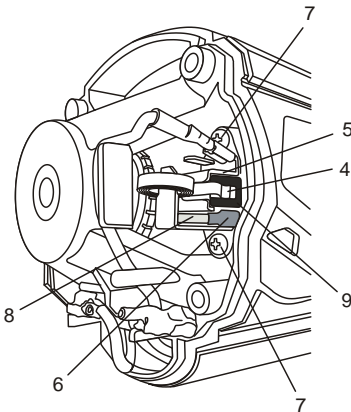

Fig. 8

INSTALLING NEW MOTOR BRUSHES

7. Once the old carbon brush has been removed, use a SOFT DRY brush to carefully remove all grinding dust from the brush holder and install the new carbon brush in the reverse order that was used to remove the worn carbon brush.
8. Reinstall the new carbon brush in reverse order of paragraphs 1 through 6.

NOTES:

- a) Make sure the braided brush wire is routed **EXACTLY** the same as the original.
 - b) Make sure the end of the coil spring is placed on top of the carbon brush (Fig. 8).
9. Turn the tool over to remove and replace the second carbon motor brush using the same procedures noted above.
 10. Once both carbon brushes have been replaced, reinstall the motor end cap and the motor end cap screws.

EXPLODED VIEW

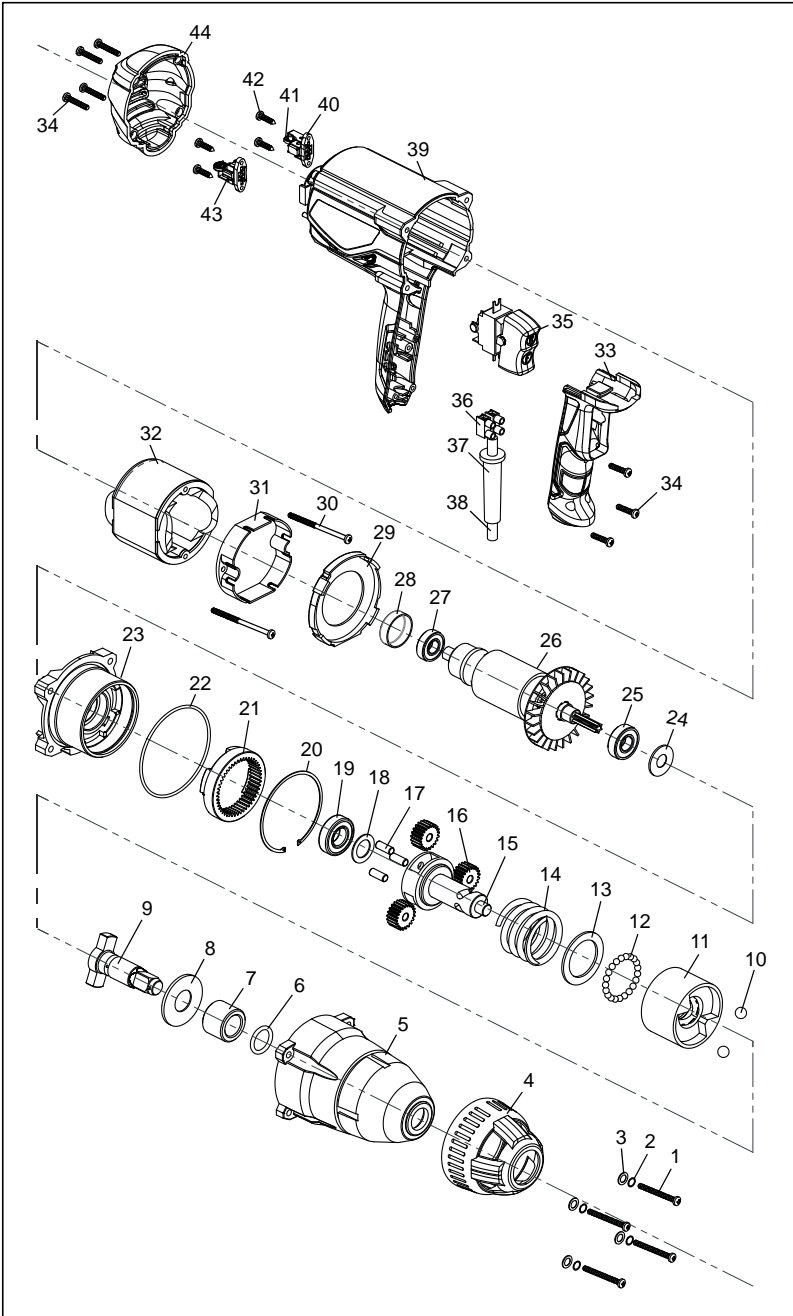

PARTS LIST

⚠ WARNING: When servicing, use only original equipment replacement parts. The use of any other parts may create a safety hazard or cause damage to the impact wrench.

Any attempt to repair or replace electrical parts on this impact wrench may create a safety hazard unless repairs are performed by a qualified technician. For more information, call the Toll-Free Helpline, at 1-866-349-8665.

Always order by PART NUMBER, not by key number.

Key #	Part #	Part Name	Quantity
1	4030090005	ST4.9x50 Screws	4
2	4040030003	5mm Lock washer	4
3	4040010011	5mm washer	4
4	3140100013	Rubber sleeve	1
5	2020050079	Aluminum shell	1
6	3140020017	O-ring	1
7	2010080084	Bushing	1
8	2030020196	Washer	1
9	2040040051	Drive shaft	1
10	4080080002	ball ϕ 6.35mm	2
11	2040200014	Impact block	1
12	4080060001	ϕ 5mm Ball bearing racer	24
13	2030020343	Washer	1
14	2050060240	Torque spring	1
15	2040040113	Intermediate shaft	1
16	2010010132	Planetary gears	3
17	4110010011	Pins	3
18	2030020229	Washer	1
19	4010010084	Bearing 6002 2RS	1
20	4100010015	Circlip	1

PARTS LIST

Key #	Part #	Part Name	Quantity
21	2010090082	Ring gear	1
22	3140020132	Oil seal ring	1
23	2020020050	Gear box	1
24	3190010023	Felt seal ring	1
25	4010010055	Bearing 6001 2RS	1
26	1010180015	Rotor	1
27	4010010048	Bearing 608 RS	1
28	3140040001	Bearing boot	1
29	3150050094	Air deflector	1
30	4003010122	ST3.9x70 Screws	2
31	3150160214	Stator spacer	1
32	1020180014	Stator	1
33	3120070132	Handle	1
34	4030010106	ST3.9x19 screws	7
35	1062020067	Switch	1
36	1250010002	Terminal block	1
37	3140010061	Strain relief	1
38	1190290015	UL approved power cord	1
39	3011180006	Housing	1
40	1230030032	Carbon brush holder assembly	2
41	2050020030	Brush flat coil tension spring	2
42	4030010146	ST2.9x18 screws	4
43	1230010149	Carbon brushes	2
44	3160010071	Motor end cap	1

PERFORMAX® IMPACT WRENCH WARRANTY

30-DAY MONEY BACK GUARANTEE:

This PERFORMAX® brand power tool carries our 30-Day Money Back Guarantee. If you are not completely satisfied with your PERFORMAX® brand power tool for any reason within thirty (30) days from the date of purchase, return the tool with your original receipt to any MENARDS® retail store, and we will provide you a refund – no questions asked.

2-YEAR LIMITED WARRANTY:

This PERFORMAX® brand power tool carries a 2-Year Limited Warranty to the original purchaser. If, during normal use, this PERFORMAX® power tool breaks or fails due to a defect in material or workmanship within two (2) years from the date of original purchase, simply bring this tool with the original sales receipt back to your nearest MENARDS® retail store. At its discretion, PERFORMAX® agrees to have the tool or any defective part(s) repaired or replaced with the same or similar PERFORMAX® product or part free of charge, within the stated warranty period, when returned by the original purchaser with original sales receipt. Notwithstanding the foregoing, this limited warranty does not cover any damage that has resulted from abuse or misuse of the Merchandise. This warranty: (1) excludes expendable parts including but not limited to blades, brushes, belts, bits, light bulbs, and/or batteries; (2) shall be void if this tool is used for commercial and/or rental purposes; and (3) does not cover any losses, injuries to persons/property or costs. This warranty does give you specific legal rights and you may have other rights, which vary from state to state. Be careful, tools are dangerous if improperly used or maintained. Seller's employees are not qualified to advise you on the use of this Merchandise. Any oral representation(s) made will not be binding on seller or its employees. The rights under this limited warranty are to the original purchaser of the Merchandise and may not be transferred to any subsequent owner. This limited warranty is in lieu of all warranties, expressed or implied including warranties or merchantability and fitness for a particular purpose. Seller shall not be liable for any special, incidental, or consequential damages. The sole exclusive remedy against the seller will be for the replacement of any defects as provided herein, as long as the seller is willing or able to replace this product or is willing to refund the purchase price as provided above. For insurance purposes, seller is not allowed to demonstrate any of these power tools for you.

For questions / comments, technical assistance or repair parts –
Please Call Toll Free at: 1-866-349-8665 (M-F 8am – 6pm)

SAVE YOUR RECEIPTS. THIS WARRANTY IS VOID WITHOUT THEM.

Distributed by: Menard, Inc., Eau Claire, WI 54703