

BENCHMARKTM MC

20V MAX 7-1/4" SLIDING COMPOUND MITRE SAW



Includes 1 battery & 1 charger.
5 Year Limited Warranty on tool
3 Year Limited Warranty on battery and charger



E114847
J0G-ZP4-185Li-JD

**READ ALL INSTRUCTIONS BEFORE FIRST USE.
KEEP THIS MANUAL FOR FUTURE REFERENCE.
KEEP AWAY FROM CHILDREN.**

Maximum initial battery voltage (measured without a load)
is 20 volts. Normal voltage is 18 volts.



**WEAR CSA APPROVED
EYE PROTECTION**



**WEAR EAR
PROTECTION**



**WEAR A
FACE MASK**

PRODUCT SPECIFICATIONS

20V MAX 7-1/4" SLIDING COMPOUND MITRE SAW	
No Load Speed	3600 RPM
Blade	7-1/4" (185mm) 40T carbide tipped/ Teflon coated
Arbor	5/8"
Mitre Stops	0, 15, 22.5, 31.6, 45°
Single Bevel	45°
Cross Cut Capacity	8" (203mm) at 90° - 6" (152mm) at 45°
Weight	26.5 Lbs. (12Kg)

BATTERY AND CHARGER	
Battery voltage	1x20V 5 Ah Li-ion (Maximum charged battery voltage, measured without load, is 20V with a nominal value of 18V)
Charger	Up to 150 minutes (#5350-010)
Replacement battery	5350-012
Replacement charger	5350-010

NEED ASSISTANCE?

Call us on our toll-free customer support line:

1-866-349-8665 (Monday through Friday 9am – 5pm Eastern Standard Time)

- Technical questions
- Replacement parts
- Parts missing from package

TABLE OF CONTENTS









Product Specifications.....	1
Table of Contents.....	2
General Safety Warnings.....	3-7
Specific Safety Rules.....	8-12
Symbols.....	13
Know Your Mitre Saw.....	14
Assembly and Operating.....	15-20
Maintenance.....	21
Exploded View.....	22
Part List.....	23-27
Warranty.....	27

GENERAL SAFETY WARNINGS

WARNING:

Before using this tool or any of its accessories, read this manual and follow all Safety Rules and Operating Instructions. The important precautions, safeguards and instructions appearing in this manual are not meant to cover all possible situations. It must be understood that common sense and caution are factors which cannot be built into the product.

EYE, EAR & LUNG PROTECTION

SYMBOL	MEANING
 DANGER  	<p>ALWAYS WEAR EYE PROTECTION THAT CONFORMS WITH CSA Z94.3 or ANSI SAFETY STANDARD Z87.1</p> <p>FLYING DEBRIS can cause permanent eye damage. Prescription eyeglasses ARE NOT a replacement for proper eye protection.</p> <p>Non-compliant eyewear can cause serious injury if broken during the operation of a power tool.</p>
 WARNING 	<p>Use hearing protection, particularly during extended periods of operation of the tool, or if the operation is noisy.</p>
 WARNING 	<p>WEAR A DUST MASK THAT IS DESIGNED TO BE USED WHEN OPERATING A POWER TOOL IN A DUSTY ENVIRONMENT.</p> <p>Dust that is created by power sanding, sawing, grinding, drilling, and other construction activities may contain chemicals that are known to cause cancer, birth defects, or other genetic abnormalities. These chemicals include:</p> <ul style="list-style-type: none"> • Lead from lead-based paints • Crystalline silica from bricks, cement, and other masonry products • Arsenic and chromium from chemically treated lumber. <p>The level of risk from exposure to these chemicals varies, according to how often this type of work is performed. In order to reduce exposure to these chemicals, work in a well-ventilated area, and use approved safety equipment, such as a dust mask that is specifically designed to filter out microscopic particles.</p>
 WARNING 	<p>To avoid electrical hazards, fire hazards or damage to the tool, use proper circuit protection.</p> <p>This tool is wired at the factory for 120 Volts AC operation. It must be connected to a 120 Volts AC, 15 Amps circuit that is protected by a time-delayed fuse or circuit breaker. To avoid shock or fire, replace power cord immediately if it is worn, cut or damaged in any way.</p>

GENERAL SAFETY RULES

 **WARNING:** Read all safety warnings and all instructions. Failure to follow the warnings and instructions may result in electric shock, fire and/or serious injury.

Save all warnings and instructions for future reference.

WORK AREA SAFETY

Keep work area clean and well lit. Cluttered or dark areas invite accidents.

Do not operate power tools in explosive atmospheres, such as in the presence of flammable liquids, gases or dust. Power tools create sparks which may ignite the dust or fumes.

Keep children and bystanders away while operating a power tool. Distractions can cause you to lose control.

ELECTRICAL SAFETY

Power tool plugs must match the outlet. Never modify the plug in any way.

Do not use any adapter plugs with earthed (grounded) power tools. Unmodified plugs and matching outlets will reduce risk of electric shock.

Avoid body contact with earthed or grounded surfaces such as pipes, radiators, ranges and refrigerators. There is an increased risk of electric shock if your body is earthed or grounded.

Do not expose power tools to rain or wet conditions. Water entering a power tool will increase the risk of electric shock.

Do not abuse the cord. Never use the cord for carrying, pulling or unplugging the power tool. Keep cord away from heat, oil, sharp edges or moving parts.

Damaged or entangled cords increase the risk of electric shock.

When operating a power tool outdoors, use an extension cord suitable for outdoor use. Use of a cord suitable for outdoor use reduces the risk of electric shock.

If operating a power tool in a damp location is unavoidable, use a residual current device (RCD) protected supply. Use of a ground fault circuit interrupter (GFCI) protected supply. Use of a ground fault circuit interrupter (GFCI) reduces the risk of electric shock.

PERSONAL SAFETY

Stay alert, watch what you are doing and use common sense when operating a power tool. Do not use a power tool while you are tired or under the influence of drugs, alcohol, or medication. A moment of inattention while operating power tools may result in serious personal injury.

Use personal protective equipment. Always wear eye protection. Protective equipment such as dust mask, non-skid safety shoes, hard hat, or hearing protection used for appropriate conditions will reduce personal injuries.

Prevent unintentional starting. Ensure the switch is in the off position before connecting to power source and/or battery pack, picking up or carrying the tool. Carrying power tools with your finger on the switch or energizing power tools that have the switch on invites accidents.

Remove any adjusting key or wrench before turning the power tool on.

A wrench or a key left attached to a rotating part of the power tool may result in personal injury.

Do not overreach. Keep proper footing and balance at all times. This enables better control of the power tool in unexpected situations.

Dress properly. Do not wear loose clothing or jewellery. Keep your hair, clothing, and gloves away from moving parts. Loose clothes, jewellery or long hair can be caught in moving parts.

If devices are provided for the connection of dust extraction and collection facilities, ensure these are connected and properly used. Use of dust collection can reduce dust-related hazards.

POWER TOOL USE AND CARE

Do not force the power tool. Use the correct power tool for your application.

The correct power tool will do the job better and safer at the rate for which it was designed.

Do not use the power tool if the switch does not turn it on and off. Any power tool that cannot be controlled with the switch is dangerous and must be repaired.

Disconnect the plug from the power source and/or the battery pack from the power tool before making any adjustments, changing accessories, or storing power tools. Such preventive safety measures reduce the risk of starting the power tool accidentally.

Store idle power tools out of the reach of children and do not allow persons unfamiliar with the power tool or these instructions to operate the power tool. Power tools are dangerous in the hands of untrained users.

Maintain power tools. Check for misalignment or binding of moving parts, breakage of parts and any other condition that may affect the power tool's operation. If damaged, have the power tool repaired before use.

Many accidents are caused by poorly maintained power tools.

Keep cutting tools sharp and clean. Properly maintained cutting tools with sharp cutting edges are less likely to bind and are easier to control.

Use the power tool, accessories, and tool bits etc. in accordance with these instructions, taking into account the working conditions and the work to be performed. Use of the power tool for operations different from those intended could result in a hazardous situation.

Hold power tools by insulated gripping surfaces when performing an operation where cutting tool may contact hidden wiring or its own cord. Contact with a "live" wire will make exposed metal parts of the tool "live" and shock the operator.

Hold power tool by insulated gripping surfaces, when performing an operation where the fastener may contact hidden wiring or its own cord. Fasteners contacting a "live" wire may make exposed metal parts of the power tool "live" and could give the operator an electric shock.

BATTERY TOOL USE AND CARE

Recharge only with the charger specified by the manufacturer. A charger that is suitable for one type of battery pack may create a risk of fire when used with another battery pack.

Use power tools only with specifically designated battery packs.

Use of any other battery packs may create a risk of injury and fire.

When battery pack is not in use, keep it away from other metal objects, like paper clips, coins, keys, nails, screws, or other small metal objects that can make a connection from one terminal to another. Shorting the battery terminals together may cause burns or a fire.

Under abusive conditions, liquid may be ejected from the battery; avoid contact. If contact accidentally occurs, flush with water. If liquid contacts eyes, additionally seek medical help. Liquid ejected from the battery may cause irritation or burns.

SERVICE

Have your power tool serviced by a qualified repair person using only identical replacement parts. This will ensure that the safety of the power tool is maintained.

BATTERY & CHARGER SAFETY

⚠ WARNING: Only use the diagnostic charger supplied with this kit to charge the 20V Li-ion battery. Charging any other batteries may damage the charger and possibly cause serious injury.

Do not store or carry the battery in a manner in which metal objects could contact the exposed metal end. Do not place the battery in aprons, pockets, drawers, etc. with loose nails, screws, keys etc. The battery could short circuit causing a fire, personal injury or damage to the battery. Store in a warm dry place.

Never attempt to open the battery for any reason. If the housing of the battery breaks or cracks, immediately discontinue use and do not recharge.

Do not charge the battery if it is wet or shows any evidence of corrosion.

A small leakage from the battery may occur under extreme usage, charging or temperature conditions. This does not indicate a failure. However, if the outer seal is broken and this leakage gets on your skin, follow these steps:

1. Wash immediately with soap and water.
2. Neutralize with a mild acid such as lemon juice or vinegar.
3. If liquid gets into your eyes, flush immediately with clean water for a minimum of 10 minutes and seek medical attention.

NOTE: The battery liquid is slightly acidic.

Do not incinerate the battery. It can explode in a fire.

Do not use an extension cord. Plug the charger cord directly into an electrical outlet.

Use the charger only in a standard 120V, 60 Hz electrical outlet.

BATTERY PACK RECYCLING



To preserve our natural resources, please recycle or dispose of batteries properly. The batteries charged by this charger may contain chemicals and metals that are harmful to the environment. Never dispose of rechargeable batteries in your normal household garbage or in landfill sites as they will add to the pollution of the environment.

SPECIFIC SAFETY RULES

⚠️ WARNING: Know your mitre saw. Do not use the mitre saw until you have read and understand this Instruction Manual. Learn the tool's applications and limitations, as well as the specific potential hazards related to this tool. Following this rule will reduce the risk of electric shock, fire, or serious injury.



Always wear eye protection. Any power tool can throw foreign objects into your eyes and cause permanent eye damage. ALWAYS wear safety goggles (not glasses) that comply with ANSI safety standard Z87.1. Everyday glasses have only impact resistant lenses. They ARE NOT safety glasses.

⚠️ WARNING: Glasses or goggles not in compliance with ANSI Z87.1 could cause serious injury when they break.

Miter saws are intended to cut wood or wood-like products, they cannot be used with abrasive cut-off wheels for cutting ferrous material such as bars, rods, studs, etc. Abrasive dust causes moving parts such as the lower guard to jam. Sparks from abrasive cutting will burn the lower guard, the kerf insert and other plastic parts.

- Use clamps to support the workpiece whenever possible. If supporting the workpiece by hand, you must always keep your hand at least 100 mm from either side of the saw blade. Do not use this saw to cut pieces that are too small to be securely clamped or held by hand. If your hand is placed too close to the saw blade, there is an increased risk of injury from blade contact.
- The workpiece must be stationary and clamped or held against both the fence and the table. Do not feed the workpiece into the blade or cut "freehand" in any way. Unrestrained or moving workpieces could be thrown at high speeds, causing injury.
- Push the saw through the workpiece. Do not pull the saw through the workpiece. To make a cut, raise the saw head and pull it out over the workpiece without cutting, start the motor, press the saw head down and push the saw through the workpiece. Cutting on the pull stroke is likely to cause the saw blade to climb on top of the workpiece and violently throw the blade assembly towards the operator.
- Never cross your hand over the intended line of cutting either in front or behind the saw blade. Supporting the workpiece "cross handed" i.e., holding the workpiece to the right of the saw blade with your left hand or vice versa is very dangerous.
- Do not reach behind the fence with either hand closer than 100 mm from either side of the saw blade, to remove wood scraps, or for any other reason while the blade is spinning. The proximity of the spinning saw blade to your hand may not be obvious and you may be seriously injured.
- Inspect your workpiece before cutting. If the workpiece is bowed or warped, clamp it with the outside bowed face toward the fence. Always make certain that there is no gap between the workpiece, fence, and table along the line of the cut. Bent or warped workpieces can twist or shift and may cause binding on the spinning saw blade while cutting. There should be no nails or foreign objects in the workpiece.

- Do not use the saw until the table is clear of all tools, wood scraps, etc., except for the workpiece. Small debris or loose pieces of wood or other objects that contact the revolving blade can be thrown with high speed.
- Cut only one workpiece at a time. Stacked multiple workpieces cannot be adequately clamped or braced and may bind on the blade or shift during cutting.
- Ensure the miter saw is mounted or placed on a level, firm work surface before use. A level and firm work surface reduces the risk of the miter saw becoming unstable.
- Plan your work. Every time you change the bevel or miter angle setting, make sure the fence will not interfere with the blade or the guarding system. Without turning the tool “ON” and with no workpiece on the table, move the saw blade through a complete simulated cut to assure there will be no interference or danger of cutting the fence.
- Provide adequate support such as table extensions, sawhorses, etc. for a workpiece that is wider or longer than the tabletop. Workpieces longer or wider than the miter saw table can tip if not securely supported. If the cut-off piece or workpiece tips, it can lift the lower guard or be thrown by the spinning blade.
- Do not use another person as a substitute for a table extension or as additional support. Unstable support for the workpiece can cause the blade to bind or the workpiece to shift during the cutting operation pulling you and the helper into the spinning blade.
- The cut-off piece must not be jammed or pressed by any means against the spinning saw blade. If confined, i.e., using length stops, the cut-off piece could get wedged against the blade and thrown violently.
- Always use a clamp or a fixture designed to properly support round material such as rods or tubing. Rods have a tendency to roll while being cut, causing the blade to “bite” and pull the work with your hand into the blade.
- Let the blade reach full speed before contacting the workpiece. This will reduce the risk of the workpiece being thrown.
- If the workpiece or blade becomes jammed, turn the miter saw off. Wait for all moving parts to stop and disconnect the plug from the power source and/or remove the battery pack. Then work to free the jammed material. Continued sawing with a jammed workpiece could cause loss of control or damage to the miter saw.
- After finishing the cut, release the switch, hold the saw head down and wait for the blade to stop before removing the cut-off piece. Reaching with your hand near the coasting blade is dangerous.
- Hold the handle firmly when making an incomplete cut or when releasing the switch before the saw head is completely in the down position. The braking action of the saw may cause the saw head to be suddenly pulled downward, causing a risk of injury.

⚠ WARNING: Do not insert the battery into the unit until complete instructions are read and understood.

- NEVER PLACE HANDS CLOSER THAN 4" (100 mm) FROM THE BLADE.
- DO NOT OPERATE THIS MACHINE until it is completely assembled and installed according to the instructions. A machine incorrectly assembled can cause serious injury.
- OBTAIN ADVICE from a qualified person if you are not thoroughly familiar with the operation of this machine. Knowledge is safety.
- MAKE CERTAIN the blade rotates in the correct direction. The teeth on the blade should point in the direction of rotation as marked on the saw.
- TIGHTEN ALL CLAMP HANDLES, knobs, and levers prior to operation. Loose clamps can cause parts or the workpiece to be thrown at high speeds.
- BE SURE all blade and blade clamps are clean, recessed sides of blade clamps are against blade and arbor screw is tightened securely. Loose or improper blade clamping may result in damage to the saw and possible personal injury.
- DO NOT WEDGE ANYTHING AGAINST THE FAN to hold the motor shaft. Damage to tool and possible personal injury may occur.
- NEVER CUT METALS or masonry. Either of these can cause the carbide tips to fly off the blade at high speeds causing serious injury.
- NEVER HAVE ANY PART OF YOUR BODY IN LINE WITH THE PATH OF THE SAW BLADE. Personal injury will occur.
- NEVER APPLY BLADE LUBRICANT TO A RUNNING BLADE. Applying lubricant could cause your hand to move into the blade resulting in serious injury.
- DO NOT place either hand in the blade area when the saw is connected to the power source. Inadvertent blade activation may result in serious injury.
- NEVER REACH AROUND OR BEHIND THE SAW BLADE. A blade can cause serious injury.
- DO NOT REACH UNDERNEATH THE SAW unless the battery has been removed from the saw. Contact with saw blade may cause personal injury.
- SECURE THE MACHINE TO A STABLE SUPPORTING SURFACE. Vibration can possibly cause the machine to slide, walk, or tip over, causing serious injury.
- USE ONLY BLADES OF THE CORRECT SIZE AND TYPE specified for this tool to prevent damage to the machine and/or serious injury.
- INSPECT BLADE FOR CRACKS or other damage prior to operation. A cracked or damaged blade can come apart and pieces can be thrown at high speeds, causing serious injury. Replace cracked or damaged blades immediately.
- CLEAN THE BLADE AND BLADE CLAMPS prior to operation. Cleaning the blade and blade clamps allows you to check for any damage to the blade or blade clamps. A cracked or damaged blade or blade clamp can come apart and pieces can be thrown at high speeds, causing serious injury.

- **DO NOT USE WARPED BLADES.** Check to see if the blade runs true and is free from vibration. A vibrating blade can cause damage to the machine and/or serious injury.
- **DO NOT** use lubricants or cleaners (particularly spray or aerosol) in the vicinity of the plastic guard. The polycarbonate material used in the guard is subject to attack by certain chemicals.
- **KEEP GUARD IN PLACE** and in working order.
- **ALWAYS USE THE KERF PLATE AND REPLACE THIS PLATE WHEN DAMAGED.** Small chip accumulation under the saw may interfere with the saw blade or may cause instability of workpiece when cutting.
- **USE ONLY BLADE CLAMPS SPECIFIED FOR THIS TOOL** to prevent damage to the machine and/or serious injury.
- **CLEAN THE MOTOR AIR SLOTS** of chips and sawdust. Clogged motor air slots can cause the machine to overheat, damaging the machine and possibly causing a short which could cause serious injury.
- **NEVER LOCK THE SWITCH IN THE “ON” POSITION.** Severe personal injury may result.
- **NEVER STAND ON TOOL.** Serious injury could occur if the tool is tipped or if the cutting tool is unintentionally contacted.

⚠ WARNING: Cutting plastics, sap coated wood, and other materials may cause melted material to accumulate on the blade tips and the body of the saw blade, increasing the risk of blade overheating and binding while cutting.

⚠ WARNING: ALWAYS use safety glasses. Everyday eyeglasses are NOT safety glasses. Also use face or dust mask if cutting operation is dusty. **ALWAYS WEAR CERTIFIED SAFETY EQUIPMENT:** • ANSI Z87.1 eye protection (CAN/CSA Z94.3), • ANSI S12.6 (S3.19) hearing protection, • NIOSH/OSHA/MSHA respiratory protection.

⚠ WARNING: Some dust created by power sanding, sawing, grinding, drilling, and other construction activities contains chemicals known to the State of California to cause cancer, birth defects or other reproductive harm. Some examples of these chemicals are: • lead from lead-based paints, • crystalline silica from bricks and cement and other masonry products, and • arsenic and chromium from chemically treated lumber. Your risk from these exposures varies, depending on how often you do this type of work. To reduce your exposure to these chemicals: work in a well-ventilated area, and work with approved safety equipment, such as those dust masks that are specially designed to filter out microscopic particles.

- Avoid prolonged contact with dust from power sanding, sawing, grinding, drilling, and other construction activities. Wear protective clothing and wash exposed areas with soap and water. Allowing dust to get into your mouth, eyes, or lay on the skin may promote absorption of harmful chemicals.















⚠ WARNING: Use of this tool can generate and/or disperse dust, which may cause serious and permanent respiratory or other injury. Always use NIOSH/OSHA approved respiratory protection appropriate for the dust exposure. Direct particles away from face and body. **WARNING:** Always wear proper personal hearing protection that conforms to ANSI S12.6 (S3.19) during use. Under some conditions and duration of use, noise from this product may contribute to hearing loss.

CAUTION: When not in use, place tool on its side on a stable surface where it will not cause a tripping or falling hazard. Some tools with large battery packs will stand upright on the battery pack but may be easily knocked over.

- When replacing the blade, make sure the replacement blade is 7 1/4" in diameter and is rated for at least 3600 RPM. Installing an incorrect blade will result in possible injury and poor cutting action.
- After changing a blade or making adjustments make sure the blade clamp screw is securely tightened. Loose blades and adjustment devices will be violently thrown.
- Never touch the blade during or immediately after use. After use, the blade is too hot to be safely touched with bare hands.

SYMBOLS

⚠ WARNING: Some of the following symbols may appear on the mitre saw. Study these symbols and learn their meaning. Proper interpretation of these symbols will allow for more efficient and safer operation of this tool.

V	Volts		Three-phase alternating current with neutral
A	Amperes		Read all documentation
Hz	Hertz		Direct current
W	Watts		No load speed
kW	Kilowatts		Alternating or direct current
μF	Microfarads		Class II Construction
L	Litres		Splash-proof construction
kg	Kilograms		Watertight construction
H	Hours		Protective grounding at terminal, Class I tools
N/cm ²	Newtons per square centimetre		Revolutions or reciprocations per minute
Pa	Pascals		Diameter
OPM	Oscillation per minute		Off position
Min	Minutes		Directional Arrow
S	Seconds		Warning symbol
~ or AC	Alternating current		Wear eye protection
3 ~	Three-phase alternating current		



E114847

J0G-ZP4-185Li-JD

This symbol designates that this tool is listed with U.S. requirements by MET Laboratories, Inc.
 UL 62841-1, UL 62841-3-9
 CAN/CSA-C22.2 No. 62841-1, CAN/CSA-C22.2 No. 62841-3-9.

KNOW YOUR 20V MAX 7 1/4" SLIDING COMPOUND MITRE SAW

- | | | |
|----------------------------|---------------------|--------------------------------------|
| 1. Build in LED | 13. Bevel scale | 25. Trenching depth adjustment screw |
| 2. LED ON/OFF switch | 14. Fence | 26. Trenching stop |
| 3. Saw arm | 15. 6mm hex key | 27. Trenching depth lock nut |
| 4. Release knob | 16. Mitre table | 28. 45°bevel adjustment screw |
| 5. Operating handle | 17. Mitre scale | 29. 0°bevel adjustment screw |
| 6. Upper fixed blade guard | 18. Table insert | 30. Release latch |
| 7. G clamp | 19. Trigger switch | 31. Side support bars (x2) |
| 8. Rotating blade guard | 20. Mitre lock knob | 32. Battery pack |
| 9. Guard retraction arm | 21. Mitre latch | 33. Battery lock |
| 10. Blade bolt cover | 22. Spindle lock | 34. Switch lock |
| 11. Dust bag | 23. Slide bars | 35. Fence |
| 12. Bevel lock | 24. Slide lock | 36. Charger |

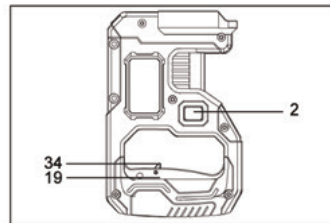
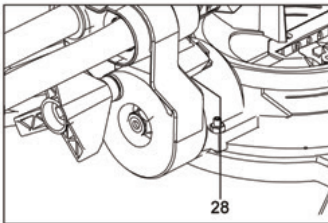
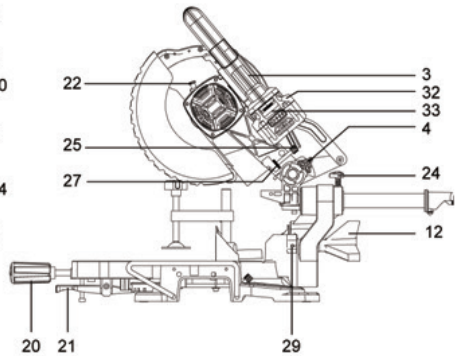
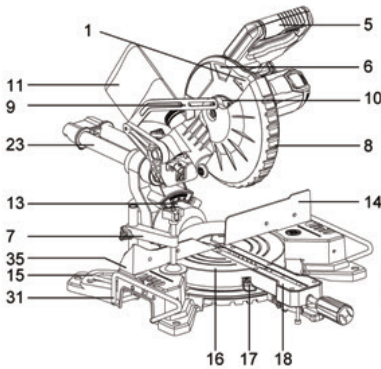

ASSEMBLY AND OPERATING

CHECKING THE BATTERY CHARGER STATUS

The level of charge remaining in the battery can be checked by using the battery LED power indicator that is contained on the end of the battery.

NOTE: The battery charge remaining may be checked while the battery is installed in the tool with the ON/OFF switch turned OFF. It may also be checked while the battery is removed from the tool. DO NOT check the battery charge remaining while the battery is in the charger. You will get a false reading and you may also damage the battery status system.

1. Press and hold the battery status button located on the end of the battery.
2. One or more of the Four LED lights in the LED window will come ON to indicate the amount of charge that is remaining in the battery as follows:

Charge Level Indicator					
Amount of Charge Remaining	0 - 10%	10 - 25%	25 - 50%	50 - 75%	75 - 100%

3. Release the battery status button to turn the LEDs OFF.



CHARGING THE BATTERY PACK

1. Place the battery charger (1) in a dry location near a 110–120V 60 Hz
2. Plug the battery charger into the outlet and make sure the green LED indicator light (5) comes ON. If it does not, refer to the chart (Fig. 2) to identify the problem.
3. Turn the battery (2) upside down and slide it onto the charger.

NOTE: Make sure the grooves (3) in the sides of the battery slide over the matching tabs on the charger (4) until the battery latch “clicks” into place.

NOTES:

1. When the charger is plugged into the wall receptacle and NO battery is on the charger, the green indicator light (5) will turn ON indicating the charger is "live".
2. When a discharged battery is installed on the charger, the green indicator light will turn OFF and the red indicator light (6) will turn ON. The red indicator light indicates the battery is being charged.
3. If the red indicator light does not come ON, check to make sure battery pack is slid fully onto the charger and the electrical outlet is working properly.
4. See Fig. 3 below for other indicator light functions.
5. A discharged battery pack should be fully charged in approximately 2.5 hrs.
6. It is normal for the battery charger to hum and be warm to the touch during operation.
7. If the battery pack does not charge properly, check to make sure the electrical outlet is "live".
8. Do NOT charge batteries when the work area or the battery temperature is at or below 5°C / 41°F or above 40.5°C / 105°F.



Fig. 1

GREEN LIGHT	RED LIGHT	BATTERY INSERTED INTO CHARGER	CHARGING STATUS
ON	OFF	NO	Charger connected to power supply
OFF	Blink	YES	Battery being charged
ON	OFF	YES	Battery fully charged
OFF	ON	YES	Battery is charged but not operational on tool. This may indicate defective / bad contact on battery.
ON	ON	YES	Charging conditions are either too hot or too cold

Fig. 2

TRANSPORTATION

Lift the mitre saw only when the saw arm is locked in the down position, the saw is switched off and the battery is removed from the power tool.

Only lift the saw by the operating handle (5) or outer castings. Do not lift the saw using the guards.

BENCH MOUNTING

The saw base has holes in each corner to facilitate bench mounting.

1. Place the saw on a level, horizontal bench or worktable using bolts (not supplied) and fix the saw to the bench using 4 bolts.
2. If desired, you can mount the saw to a piece of 1/2" (13 mm) or thicker plywood which can then be clamped to your work support or moved to other job sites and re-clamped.

⚠ CAUTION. Make sure that the mounting surface is not warped as an uneven surface can cause binding and inaccurate sawing.

RELEASE KNOB

The release knob (4) is provided for holding the cutting head down while transporting or storing the mitre saw. The saw must never be used with the release knob locking the head down.

MITRE TABLE LOCKS

The mitre table locks (20) are used to lock the table at the desired mitre angle.

The mitre saw cuts from 0° to 45°. To adjust the mitre angle loosen the mitre table locks (20 & 21) and rotate the mitre table to the desired position. The mitre table features positive click stops at 0°, 15°, 22.5°, 30° and 45° for quick setting of common mitre angles.

BEVEL LOCK

The bevel lock (12) is used to set the blade at the desired bevel angle. The mitre saw bevel cuts from 0° to 45° to the left. To adjust the bevel angle loosen the bevel lock and adjust the saw arm to the desired bevel angle.

SPINDLE LOCK BUTTON

The spindle lock button (22) prevents the blade in the saw from rotating. Depress and hold the spindle lock button while installing, changing, or removing the blade.

ROTATING LOWER BLADE GUARD

The rotating lower blade guard (8) provides protection from both sides of the blade. It retracts over the upper blade guard (6) as the saw is lowered into the workpiece.

TURNING ON AND OFF

1. To turn the saw on press switch lock (34) to left and depress and hold the on/off trigger switch (19).
2. To turn the saw off release the switch lock (34) and on/off trigger switch (19).

DUST EXTRACTION

1. Fit the dust bag (11) to the dust extraction port.
2. A vacuum dust extraction device can be connected to the dust extraction port. Use a suitable vacuum adaptor if necessary. The dust extraction port has an internal diameter of 1-1/2".

SETTING THE TABLE SQUARE WITH THE BLADE

1. Make sure that the battery is removed from the power point.
2. Push the saw arm (3) down to its lowest position and engage the release knob (4) to hold the saw arm in the transport position.
3. Loosen the mitre locks (20) and lift the mitre latch (21).
4. Rotate the table (16) until the pointer is positioned at 0°.
5. Release mitre latch (21) and tighten the mitre locks (20).
6. Loosen the bevel lock (12) and set the saw arm (3) at 0°bevel (the blade at 90° to the mitre table). Tighten the bevel lock (12).
7. Place a set square against the table (16) and the flat part of the blade.
8. Rotate the blade by hand and check the blade-to-table alignment at several points.
9. The edge of the set square and the saw blade should be parallel.
10. If the saw blade angles away from the set square, adjust as follows.
11. Use a 10 mm wrench or adjustable wrench to loosen the lock nut securing the 0° bevel adjustment screw (29). Also, loosen the bevel lock (12).
12. Adjust the 0° bevel adjustment screw (29) using a 4 mm hex key to bring the saw blade into alignment with the square.
13. Loosen the Phillips head screw holding the pointer of the bevel scale (13) and adjust the position of the pointer so that it accurately indicates zero on the scale. Retighten the screw.
14. Retighten the bevel lock (12) and the lock nut securing the 0° bevel adjustment screw (29).

SETTING THE FENCE SQUARE WITH THE TABLE

1. Make sure that the battery is removed from the saw.
2. Push the saw arm (3) down to its lowest position and engage the release knob (4) to hold the saw arm in the transport position.
3. Loosen the mitre locks (20) and lift the latch (21).
4. Rotate the table (16) until the pointer is positioned at 0°.
5. Release mitre latch (21) and tighten the mitre locks.
6. Using a 5 mm hex key, loosen the two screws securing the fence (14) to the base.
7. Place a square against the fence (14) and alongside the blade.
8. Adjust the fence (14) until it is square with the blade.
9. Tighten the screws securing the fence (14).
10. Loosen the Phillips head screw holding the pointer of the mitre scale (17) and adjust it so that it accurately indicates the zero position on the mitre scale.
11. Retighten the screw securing the mitre scale pointer.

CHANGING A BLADE

1. Make sure that the battery is removed from the power point.
2. Push down on the operating handle (5) and pull the release knob (4) to disengage the saw arm (3).
3. Raise the saw arm (3) to its highest position.
4. Loosen the cover plate screw about 2 turns with a Phillips screwdriver. Do not remove this screw from the tool.
5. Pull the rotating blade guard (8) down. When the rotating blade guard (8) is positioned over the upper fixed blade guard (6) it is possible to access the blade bolt.
6. Lift and hold up the lower blade guard (8) to expose the threaded blade bolt.
7. Hold the rotating guard (8) up and press the spindle lock button (22). Rotate the blade until the spindle locks.
8. Use the 6 mm hex key provided to loosen and remove the blade bolt. (Loosen in a clockwise direction as the blade screw has a left-hand thread).
9. Remove the flat washer, outer blade washer and the blade.
10. Wipe a drop of oil onto the inner blade washer and the outer blade washer where they contact the blade.
11. Fit the new blade onto the spindle taking care that the inner blade washer sits behind the blade.
12. Replace the outer blade washer.
13. Depress the spindle lock button and replace the flat washer and blade bolt.
14. Use the 6 mm hex key to tighten the blade bolt securely (tighten in an anti-clockwise direction).

15. Lower the blade guard, hold the rotating lower blade guard, and blade bolt cover in position and tighten the fixing screw to secure the blade bolt cover in position.
16. Check that the blade guard operates correctly and covers the blade as the saw arm is lowered.
17. Connect the saw to the power supply and run the blade to make certain that it is operating correctly.

CROSS CUT

If possible, always use a clamping device such as a 'G' clamp to secure your workpiece.

When cutting your workpiece, keep your hands well away from the blade area. Do not remove a cut-off piece on the right-hand side of the blade using your left hand.

A crosscut is made by cutting across the grain of the workpiece. A 90° crosscut is made with the mitre table set at 0°. Mitre crosscuts are made with the table set at some angle other than zero.

To slide cut wide boards, Unlock the slide lock knob (24), and allow the cutting head assembly to move freely.

1. Pull on the release knob (4) and lift the saw arm (3) to its full height.
2. Loosen the mitre locks (20) and lifting the mitre latch (21).
3. Rotate the mitre table (16) until the pointer aligns with the desired angle.
4. Release mitre latch (21) and retighten the mitre locks (20).
5. Place the workpiece flat on the table with one edge securely against the fence (14).
6. When cutting long pieces of timber, support the release latch (30). Allow the blade to reach maximum speed and slowly lower the blade into and through the workpiece.
10. Release the switch trigger (19) and allow the saw blade to stop rotating before raising the blade out of the workpiece. Wait until the blade stops before removing the workpiece.

TO SLIDE CUT WIDE BOARDS

To slide cut wide boards, Unlock the slide lock (24), and allow the cutting head assembly to move freely.

SETTING CUTTING DEPTH

The depth of cut can be preset for even and repetitive shallow cuts.

1. Slide the Slide lock (24) towards the front position.
2. Loosen the ITrenching depth adjustment screw (25) to free the Slide bars (23), turn the stop knob until the cutting head down until the teeth of the blade are at the desired depth.
3. While holding the upper arm in that position, tighten the lock nut to secure the stop knob.
4. Recheck the blade depth by moving the cutting head front to back through the full motion of typical cut along the control arm.

MAINTENANCE

⚠ WARNING: Always remove battery pack from your tool when you are assembling parts, making adjustments, cleaning, or when not in use. Removing battery pack will prevent accidental starting that could cause serious personal injury.

⚠ WARNING: When servicing only use identical replacement parts. Use of any other parts may create a hazard or cause product damage.

⚠ WARNING: Always wear safety goggles or safety glasses with side shields during power tool operation or when blowing dust. If operation is dusty, also wear a dust mask.

GENERAL MAINTENANCE

Avoid using solvents when cleaning plastic parts. Most plastics are susceptible to damage from various types of commercial solvents and may be damaged by their use. Use clean cloths to remove dirt, dust, oil, grease, etc.

⚠ WARNING: Do not at any time let brake fluids, gasoline, petroleum-based products, penetrating oils, etc., come in contact with plastic parts. Chemicals can damage, weaken, or destroy plastic which may result in serious personal injury. Electric tools used on fiberglass material, wallboard, spackling compounds, or plaster are subject to accelerated wear and possible premature failure because the fiberglass chips and grindings are highly abrasive to bearings, brushes, commutators, etc. Consequently, we do not recommend using this tool for extended work on these types of materials. However, if you do work with any of these materials, it is extremely important to clean the tool using compressed air.

LUBRICATION

All of the bearings in this tool are lubricated with a sufficient amount of high-grade lubricant for the life of the unit under normal conditions. Therefore, no further lubrication is required.

ENVIRONMENTAL PROTECTION

Information for (private householders) for the environmentally responsible disposal of Waste Electrical and Electronic Equipment (WEEE)



This symbol on products and/or accompanying documents indicates that used and end of life electrical and electronic equipment should not be disposed of in household waste. For the proper disposal, treatment, recovery, and recycling, please take these products to designated collection points, where they will be accepted on a free of charge basis. Alternatively, in some countries you may be able to return your products to your retailer upon the purchase of an equivalent new product. Disposing of this product correctly will help to save valuable resources and prevent any potential adverse effects on human health and the environment which could otherwise arise from inappropriate waste disposal and handling. Please contact your local authority for further details of your nearest designated collection point. Penalties may be applicable for incorrect disposal of this waste in accordance with national legislation.

EXPLODED VIEW

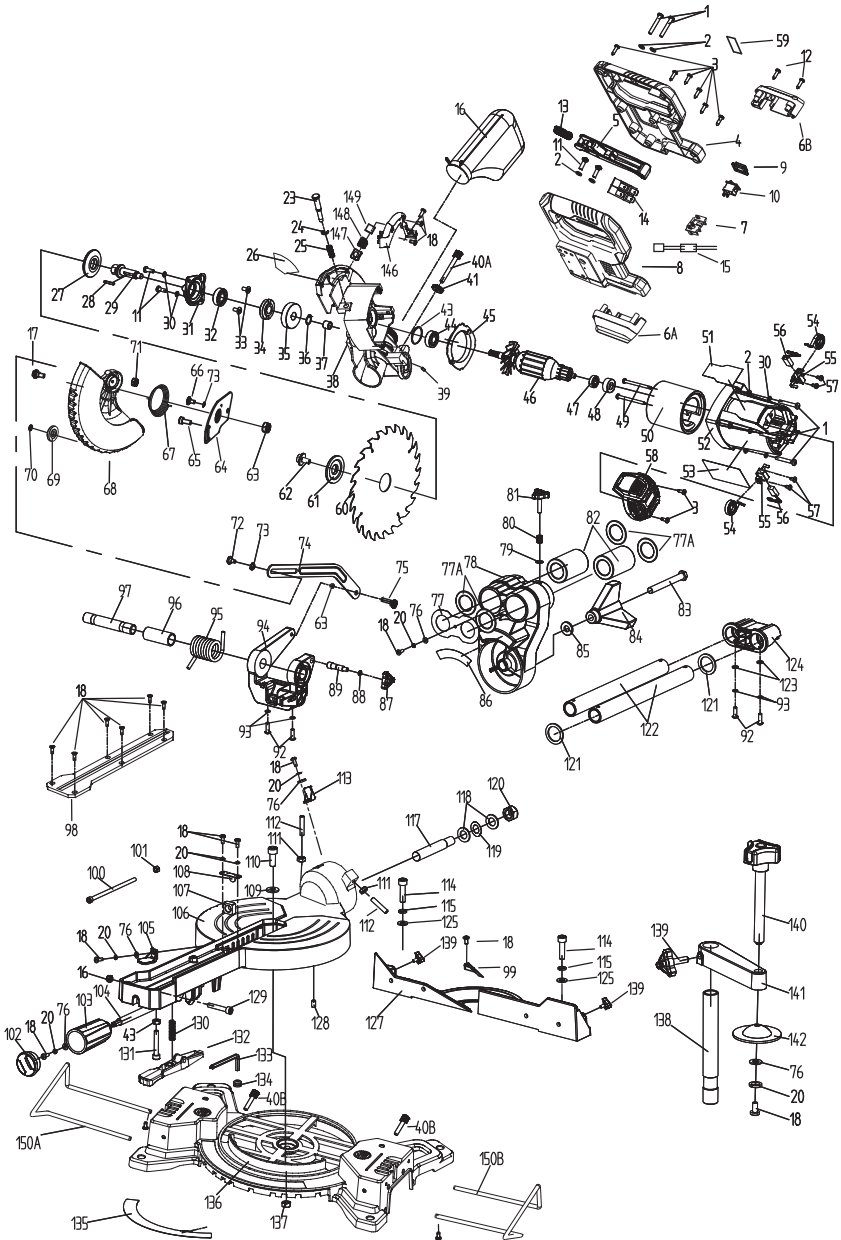

PARTS LIST

⚠ WARNING: When servicing, use only original equipment replacement parts. The use of any other parts may create a safety hazard or cause damage to the saw. Any attempt to repair or replace electrical parts on this saw may create a safety hazard unless repairs are performed by a qualified technician.

For more information, call the Toll-free Helpline, at 1-866-349-8665, Monday – Friday from 9 am to 5 pm Eastern Standard Time.

Always order by PART NUMBER, not by key number.

Part #	Part Name	Quantity
1347-001-1	TAP SCREW M5X35	6
1347-001-2	WASHER INNER HOLE $\Phi 5$	13
1347-001-3	SCREW ST4.2X13	8
1347-001-4	UPPER GRIP WITH OVERMOULD	1
1347-001-5	TRIGGER BUTTON ASSEMBLY	1
1347-001-6A	BATTER FOOT (JD LOWER)	1
1347-001-6B	BATTER FOOT (JD UPPER)	1
1347-001-7	TERMINAL BLOCK	1
1347-001-8	LOWER GRIP WITH OVERMOULD	1
1347-001-9	WORK LIGHT COVER	1
1347-001-10	SMALL SWITCH	1
1347-001-11	SCREW M5X14	5
1347-001-12	SCREW ST4.2*16	2
1347-001-13	TRIGGER SPRING ($\emptyset 1X\emptyset 7X35$)	1
1347-001-14	MICRO SWITCH MSF-2130, 30A/42VDC	1
1347-001-15	LED PCB (DK-D282-4, INPUT 18V, OUTPUT 0.5W)	1
1347-001-16	DUST BAG	1
1347-001-17	SHAFT SCREW M6X12.5	1
1347-001-18	SCREW M4X10	19
1347-001-20	$\emptyset 4$ SPRING WASHER	10
1347-001-23	S45C (3G185 2MMLONGER)RETENTION PIN	1
1347-001-24	$\Phi 6$ SNAP SPRING	1
1347-001-25	LOCKING PIN SPRING	1
1347-001-26	LOGO LABEL	1
1347-001-27	INNER PLATE	1
1347-001-28	FLAT KEY 3X3X20	1
1347-001-29	OUTPUT SHAFT	1
1347-001-30	SPRING WASHER (INNER HOLE $\Phi 5$)	8

Part #	Part Name	Quantity
1347-001-31	FRONT COVER	1
1347-001-32	6001 BEARING	1
1347-001-33	M4X10 SCREW	2
1347-001-34	FASTENING BLOCK	1
1347-001-35	GEAR	1
1347-001-36	Φ12 SHAFT SNAP RING	1
1347-001-37	COPPER POWDER BUSHING (Φ12*Φ8*10)	1
1347-001-38	UPPER GUARD	1
1347-001-39	M5X12 SCREW	1
1347-001-40A	HEIGHT ADJUSTED BUTTON (M6X50)	1
1347-001-40B	HEIGHT ADJUSTED BUTTON	2
1347-001-41	KNURL NUT M6	1
1347-001-43	O TYPE RING Φ25.7*1.8	1
1347-001-44	6000 BEARING	1
1347-001-45	AIR GUIDE	1
1347-001-46	ROTOR ASSEMBLY	1
1347-001-47	607 BEARING	1
1347-001-48	RUBBER SLEEVE (MATCH 607 BEARING)	1
1347-001-49	ST4.2X70 SCREW	2
1347-001-50	STATOR ASSEMBLY	1
1347-001-51	RATING LABEL	1
1347-001-52	HOUSING	1
1347-001-53	WARNING STICKER	1
1347-001-54	SPIRAL SPRING	2
1347-001-55	BRUSH HOLDER	2
1347-001-56	BRUSH ASSEMBLY	2
1347-001-57	ST4X10 SCREW	4
1347-001-58	MOTOR COVER	1
1347-001-59	WARNING STICKER	1
1347-001-60	BLADE	1
1347-001-61	OUT FLANGE	1
1347-001-62	M8X16 SCREW (REVERSED THREAD)	1
1347-001-63	M6 LOCKING NUT	2
1347-001-64	GUARD SUPPORT	1
1347-001-65	M5X10 SCREW	1
1347-001-66	M5X10 SHAFT SCREW	1

Part #	Part Name	Quantity
1347-001-67	GUARD TWIST SPRING	1
1347-001-68	LOWER GUARD	1
1347-001-69	GUARD ROLLER	1
1347-001-70	QUICK NUT $\Phi 5$	1
1347-001-72	M5X10 SHAFT SCREW	1
1347-001-73	$\text{\O}12.7X\text{\O}7.5X0.4$ WASHER	3
1347-001-74	ECCENTRIC ROD	1
1347-001-75	M6X20 ECCENTRIC SCREW	1
1347-001-76	WASHER INNER HOLE $\Phi 4$	5
1347-001-77	BEARING COVER	1
1347-001-78	CRANK SHAFT	1
1347-001-79	WASHER (INNER HOLE $\Phi 6$)	1
1347-001-80	COMPRESSOR SPRING $\Phi 1X\Phi 8.7X11$	1
1347-001-81	LOCKING SCREW $\Phi M6X25\Phi$	1
1347-001-82	$\Phi 25*\Phi 40*58$ BEARING	2
1347-001-83	M10X85 SCREW	1
1347-001-84	BEVEL CLAMP KNOB	1
1347-001-85	$\Phi 22X\Phi 10.3X3$ WASHER WITH TEETH	1
1347-001-86	BEVEL STICKER	1
1347-001-87	LOCKING PIN SLEEVE	1
1347-001-88	6X1 O TYPE RING	1
1347-001-89	LOCKING PIN	1
1347-001-92	M6X20 SCREW	4
1347-001-93	SPRING WASHER	4
1347-001-94	FRAME	1
1347-001-95	BIG TWIST SPRING	1
1347-001-96	TWIST SPRING BUSHING	1
1347-001-97	ROTATED SHAFT (HOLLOW $\Phi 16X\Phi 12X95$)	1
1347-001-98	CUTTING PLATE	1
1347-001-99	BLOCK PROTECTION	1
1347-001-100	M5X110 (THREAD 30LENGTH) SCREW	1
1347-001-101	M6 SCREW	2
1347-001-102	BEVEL CLAMP KNOB CAP	1
1347-001-103	BEVEL CLAMP KNOB	1
1347-001-104	BEVEL LOCKING LEVER M10	1
1347-001-105	BEVEL INDICATOR (PC+SILK PRINT)	1

Part #	Part Name	Quantity
1347-001-106	TABLE	1
1347-001-107	SQUARE NUT M10	1
1347-001-108	LOCKING PLATE	1
1347-001-109	WASHER (INNER HOLE Φ 8)	1
1347-001-110	M8X20 SCREW	1
1347-001-111	M6 NUT	2
1347-001-112	M6X30 SCREW	2
1347-001-113	BEVEL INDICATOR (PC+SILK PRINT)	1
1347-001-114	M8X30 SCREW	2
1347-001-115	SPRING WASHER	2
1347-001-117	CRANK SHAFT (FRONT M12)	1
1347-001-118	Φ 12.2* Φ 22*1.5T WASHER	2
1347-001-119	Φ 22X Φ 12.7X0.3 WASHER	1
1347-001-120	ANTI-LOOSE NUT M12	1
1347-001-121	RUBBER WASHER	2
1347-001-122	GUIDE ROD	2
1347-001-123	WASHER (INNER HOLE Φ 6)	2
1347-001-124	GUIDE SEAT	1
1347-001-125	8 WASHERS	2
1347-001-127	FIXED BLOCK	1
1347-001-128	M6X10 SCREW WITH GLUE	1
1347-001-129	M6X35 SCREW	1
1347-001-130	BEVEL BLOCK SPRING	1
1347-001-131	M6X50 SCREW	1
1347-001-132	BEVEL BLOCK	1
1347-001-133	ALLEN (6X85L)	1
1347-001-134	COIL	1
1347-001-135	BEVEL SCALE	1
1347-001-136	BASE	1
1347-001-137	ANTI-LOOSE NUT	1
1347-001-138	CLAMP ROD (HOLLOW Φ 16X Φ 12X125)	1
1347-001-139	CLAMP KNOB(M6X10)	3
1347-001-140	CLAMP KNOB	1
1347-001-141	ALUMINUM LINK ROD	1
1347-001-142	CLAMP	1
1347-001-146	LED COVER	1

Part #	Part Name	Quantity
1347-001-147	LED CAP	1
1347-001-148	LED SEAT	1
1347-001-149	LED PCB	1
1347-001-150A	EXTEND LEVEL (L)	1
1347-001-150B	EXTEND LEVEL (R)	1

WARRANTY

BENCHMARK WARRANTY FOR 20V MAX 7-1/4" SLIDING COMPOUND MITRE SAW

If this Benchmark tool fails due to a defect in material or workmanship within five years from the date of purchase, return it to any Home Hardware store with the original bill of sale for exchange. Three year warranty for the battery and charger. This warranty does not include expendable parts including but not limited to blades, brushes, belts, light bulbs.

This warranty covers defects in material or workmanship only. It does not cover normal wear and tear, failure due to abuse/misuse, or defects caused by careless or accidental mishandling. If this Benchmark product is used for commercial or rental purposes, this warranty does not apply.

20V MAX 7-1/4" SLIDING COMPOUND MITRE SAW



5 Year Limited Warranty

3 Year Limited Warranty on Battery and Charger

BENCHMARKTM_{MC}

BENCHMARK TOOLS CANADA

ST. JACOBS, ONTARIO N0B 2N0

© 01 / 2021 Home Hardware Stores Limited

CUSTOMER SERVICE/TECH SUPPORT

1-866-349-8665

1347-001

Made in China



* This Benchmark™ product carries a five (5) year LIMITED warranty against defects in workmanship and materials. The charger and batteries carry a three (3) year LIMITED warranty. See Owner's Manual for full details.



E114847

J0G-ZP4-185Li-JD

**READ ALL INSTRUCTIONS BEFORE FIRST USE.
KEEP THIS MANUAL FOR FUTURE REFERENCE.
KEEP AWAY FROM CHILDREN.**

Maximum initial battery voltage (measured without a load)
is 20 volts. Normal voltage is 18 volts.



**WEAR CSA APPROVED
EYE PROTECTION**



**WEAR EAR
PROTECTION**



**WEAR A
FACE MASK**