

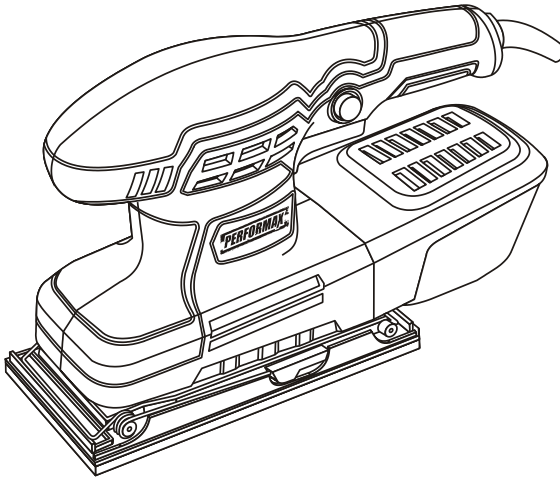

# 1/3 SHEET SANDER

241-0971

## Owner's Manual



### PRODUCT SPECIFICATIONS

Rating:	120 V, 60 Hz AC
Amperes:	2.2 Amp.
Speed:	12,000 OPM (no load)
Sanding pad size:	3 1/2" X 7 3/8" (90 X 187 mm)
Replacement sandpaper size:	1/3 sheet (3 1/2" X 9") (90 X 229 mm)
Weight:	3 lb 10 oz (1.6 kg)

#### Need Assistance?

Call us on our toll free customer support line:

1-866-349-8665

- Technical questions
- Replacement parts
- Parts missing from package

# TABLE OF CONTENTS

Product specifications .....	1
Table of contents .....	2
General safety warnings .....	3-4
Eye, ear & lung protection .....	3-4
Electrical safety .....	4
Power tool safety .....	5-6
General safety rules .....	5
Work area .....	5
Electrical safety .....	5
Personal safety .....	5-6
Power tool use and care.....	6
Service .....	6
Specific safety rules .....	7
Extension cord safety .....	8
Symbols .....	9
Know your sander .....	10
Available accessories .....	10
Assembly and operating .....	11-13
Installing a sandpaper .....	11
Punching holes in sandpaper .....	11
ON/OFF trigger switch .....	11
Lock-on button .....	12
Sandpaper selection .....	12
Sanding .....	12-13
Cleaning the dust box .....	13
Maintenance .....	14
Exploded view .....	15
Parts listing .....	16
Warranty .....	17

# GENERAL SAFETY WARNINGS



**WARNING:** Before using this tool or any of its accessories, read this manual and follow all Safety Rules and Operating Instructions. The important precautions, safeguards and instructions appearing in this manual are not meant to cover all possible situations. It must be understood that common sense and caution are factors which cannot be built into the product.

This instruction manual includes the following:

- General Safety Rules
- Specific Safety Rules and Symbols
- Functional Description
- Assembly
- Operation
- Maintenance
- Accessories

## EYE, EAR & LUNG PROTECTION



**ALWAYS WEAR EYE PROTECTION THAT CONFORMS WITH CSA REQUIREMENTS or ANSI SAFETY STANDARD Z87.1**

FLYING DEBRIS can cause permanent eye damage. Prescription eyeglasses ARE NOT a replacement for proper eye protection.



**WARNING:** Non-compliant eyewear can cause serious injury if broken during the operation of a power tool.



**WARNING:** Use hearing protection, particularly during extended periods of operation of the tool, or if the operation is noisy.

**SAVE THESE INSTRUCTIONS FOR REFERENCE**

# GENERAL SAFETY WARNINGS

## EYE, EAR & LUNG PROTECTION – cont'd



**WEAR A DUST MASK THAT IS DESIGNED TO BE USED WHEN OPERATING A POWER TOOL IN A DUSTY ENVIRONMENT.**



**WARNING:** Dust that is created by power sanding, sawing, grinding, drilling, and other construction activities may contain chemicals that are known to cause cancer, birth defects, or other genetic abnormalities. These chemicals include:

Lead from lead-based paints

Crystalline silica from bricks, cement, and other masonry products

Arsenic and chromium from chemically treated lumber

The level of risk from exposure to these chemicals varies, according to how often this type of work is performed. In order to reduce exposure to these chemicals, work in a well-ventilated area, and use approved safety equipment, such as a dust mask that is specifically designed to filter out microscopic particles.

## ELECTRICAL SAFETY



**WARNING:** To avoid electrical hazards, fire hazards or damage to the tool, use proper circuit protection.

This tool is wired at the factory for 120V AC operation. It must be connected to a 120V AC, 15 AMP circuit that is protected by a time-delayed fuse or circuit breaker. To avoid shock or fire, replace power cord immediately if it is worn, cut or damaged in any way.

**SAVE THESE INSTRUCTIONS FOR REFERENCE**

# POWER TOOL SAFETY

**⚠ WARNING: Read all safety warnings and all instructions.** Failure to follow the warnings and instructions may result in electric shock, fire and/or serious injury.

**Save all warnings and instructions for future reference.**

## Work area safety

**Keep work area clean and well lit.** Cluttered or dark areas invite accidents.

**Do not operate power tools in explosive atmospheres, such as in the presence of flammable liquids, gases or dust.** Power tools create sparks which may ignite the dust or fumes.

**Keep children and bystanders away while operating a power tool.** Distractions can cause you to lose control.

## Electrical safety

**Power tool plugs must match the outlet. Never modify the plug in any way. Do not use any adapter plugs with earthed (grounded) power tools.** Unmodified plugs and matching outlets will reduce risk of electric shock.

**Avoid body contact with earthed or grounded surfaces such as pipes, radiators, ranges and refrigerators.** There is an increased risk of electric shock if your body is earthed or grounded.

**Do not expose power tools to rain or wet conditions.** Water entering a power tool will increase the risk of electric shock.

**Do not abuse the cord. Never use the cord for carrying, pulling or unplugging the power tool. Keep cord away from heat, oil, sharp edges or moving parts.** Damaged or entangled cords increase the risk of electric shock.

**When operating a power tool outdoors, use an extension cord suitable for outdoor use.** Use of a cord suitable for outdoor use reduces the risk of electric shock.

**If operating a power tool in a damp location is unavoidable, use a ground fault circuit interrupter (GFCI) protected supply.** Use of a ground fault circuit interrupter (GFCI) reduces the risk of electric shock.

## Personal safety

**Stay alert, watch what you are doing and use common sense when operating a power tool. Do not use a power tool while you are tired or under the influence of drugs, alcohol or medication.** A moment of inattention while operating power tools may result in serious personal injury.

**Use personal protective equipment. Always wear eye protection.** Protective equipment such as dust mask, non-skid safety shoes, hard hat, or hearing protection used for appropriate conditions will reduce personal injuries.

**Prevent unintentional starting. Ensure the switch is in the off-position before connecting to power source and/or battery pack, picking up or carrying the tool.**

Carrying power tools with your finger on the switch or energizing power tools that have the switch on invites accidents.

**Remove any adjusting key or wrench before turning the power tool on.** A wrench or a key left attached to a rotating part of the power tool may result in personal injury.

**Do not overreach. Keep proper footing and balance at all times.** This enables better control of the power tool in unexpected situations.

**SAVE THESE INSTRUCTIONS FOR REFERENCE**

# POWER TOOL SAFETY

## *PERSONAL SAFETY – cont'd*

**Dress properly. Do not wear loose clothing or jewelry. Keep your hair, clothing and gloves away from moving parts.** Loose clothes, jewelry or long hair can be caught in moving parts.

**If devices are provided for the connection of dust extraction and collection facilities, ensure these are connected and properly used.** Use of dust collection can reduce dust-related hazards.

### **Power tool use and care**

**Do not force the power tool. Use the correct power tool for your application.** The correct power tool will do the job better and safer at the rate for which it was designed.

**Do not use the power tool if the switch does not turn it on and off.** Any power tool that cannot be controlled with the switch is dangerous and must be repaired.

**Disconnect the plug from the power source and/or the battery pack from the power tool before making any adjustments, changing accessories, or storing power tools.** Such preventive safety measures reduce the risk of starting the power tool accidentally.

**Store idle power tools out of the reach of children and do not allow persons unfamiliar with the power tool or these instructions to operate the power tool.** Power tools are dangerous in the hands of untrained users.

**Maintain power tools. Check for misalignment or binding of moving parts, breakage of parts and any other condition that may affect the power tool's operation. If damaged, have the power tool repaired before use.** Many accidents are caused by poorly maintained power tools.

**Keep cutting tools sharp and clean.** Properly maintained cutting tools with sharp cutting edges are less likely to bind and are easier to control.

**Use the power tool, accessories and tool bits etc. in accordance with these instructions, taking into account the working conditions and the work to be performed.** Use of the power tool for operations different from those intended could result in a hazardous situation.

**Hold power tools by insulated gripping surfaces when performing an operation where cutting tool may contact hidden wiring or its own cord.** Contact with a "live" wire will make exposed metal parts of the tool "live" and shock the operator

### **Service**

**Have your power tool serviced by a qualified repair person using only identical replacement parts.** This will ensure that the safety of the power tool is maintained.

**SAVE THESE INSTRUCTIONS FOR REFERENCE**

## SPECIFIC SAFETY RULES

**⚠ WARNING: Know your sander. Do not plug in the sander until you have read and understand this Instruction Manual. Learn the tool's applications and limitations, as well as the specific potential hazards related to this tool.** Following this rule will reduce the risk of electric shock, fire, or serious injury.



Always wear eye protection. Any power tool can throw foreign objects into your eyes and cause permanent eye damage.

ALWAYS wear safety goggles (not glasses) that comply with ANSI safety standard Z87.1. Everyday glasses have only impact resistant lenses. They ARE NOT safety glasses.

**⚠ WARNING: Glasses or goggles not in compliance with ANSI Z87.1 could cause serious injury when they break.**

**⚠ WARNING: Always use a dust mask when sanding.**

**⚠ WARNING: Always use hearing protection when sanding, particularly during extended periods of operation.**

**⚠ WARNING: Always unplug the tool from the power source before changing the sanding disc or buffing pad and when cleaning the tool.**

Do not wear gloves, neckties or loose clothing.

Secure the workpiece. Use clamps or a vice to hold the work when practical. It is safer than using your hand and it frees both hands to operate the tool.

Do not sand material too small to be securely held.

Make sure there are no nails or foreign objects in the part of the workpiece to be sanded.

Always keep hands out of the path of the sanding pad. Avoid awkward hand positions where a sudden slip could cause your hand to move into the path of the sanding pad.

To avoid injury from accidental starting, always remove the plug from the power source before installing or removing sandpaper or the dust box.

**SAVE THESE INSTRUCTIONS FOR REFERENCE**

# EXTENSION CORD SAFETY

**⚠ WARNING: Keep the extension cord clear of the working area.** Position the cord so it will not get caught on the workpiece, tools or any other obstructions while you are working with the power tool.

Make sure any extension cord used with this tool is in good condition. When using an extension cord, be sure to use one of heavy enough gauge to carry the current the tool will draw. An undersized cord will cause a drop in line voltage resulting in loss of power and overheating.

The table below shows the correct size to use according to cord length and nameplate ampere rating. If in doubt, use the next heavier gauge. The smaller the gauge number the heavier the cord.

Be sure your extension cord is properly wired and in good condition. Always replace a damaged extension cord or have it repaired by a qualified electrician before using it. Protect your extension cord from sharp objects, excessive heat and damp or wet areas.

Use a separate electrical circuit for your power tools. This circuit must not be less than 14 gauge wire and should be protected with either a 15 A time delayed fuse or circuit breaker. Before connecting the power tool to the power source, make sure the switch is in the OFF position and the power source is the same as indicated on the nameplate. Running at lower voltage will damage the motor.





<b>MINIMUM GAUGE (AWG) EXTENSION CORDS (120 V use only)</b>					
Amperage rating		Total length			
More than	Not more than	25' (7.5 m)	50' (15 m)	100' (30 m)	150' (45 m)
0	6	18	16	16	14
6	10	18	16	14	12
10	12	16	16	14	12
12	16	14	12	Not Applicable	











**SAVE THESE INSTRUCTIONS FOR REFERENCE**



# SYMBOLS

**⚠ WARNING:** Some of the following symbols may appear on the sander. Study these symbols and learn their meaning. Proper interpretation of these symbols will allow for more efficient and safer operation of this tool.

<b>V</b>	Volts
<b>A</b>	Amperes
<b>Hz</b>	Hertz
<b>W</b>	Watts
<b>kW</b>	Kilowatts
<b>μF</b>	Microfarads
<b>L</b>	Liters
<b>kg</b>	Kilograms
<b>H</b>	Hours
<b>N/cm<sup>2</sup></b>	Newtons per square centimeter
<b>Pa</b>	Pascals
<b>OPM</b>	Oscillations per minute
<b>Min</b>	Minutes
<b>S</b>	Seconds
 or a.c.	Alternating current
	Three-phase alternating current
	Three-phase alternating current with neutral
	Read all safety warnings and instructions

	Direct current
<b>n<sub>0</sub></b>	No load speed
	Alternating or direct current
	Class II construction
	Splash-proof construction
	Watertight construction
	Protective grounding at grounding terminal, Class I tools
<b>.../min</b>	Revolutions or reciprocations per minute
<b>∅</b>	Diameter
<b>0</b>	Off position
	Directional arrow
	Warning symbol
	Wear your safety glasses
	Wear your dust mask
	Wear your hearing protection



This symbol designates that this tool is listed with U.S. requirements by ETL Testing Laboratories, Inc. Conforms to UL Std. 60745-1 and 60745-2-4.

**SAVE THESE INSTRUCTIONS FOR REFERENCE**

# KNOW YOUR SANDER

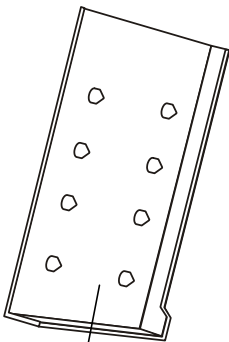
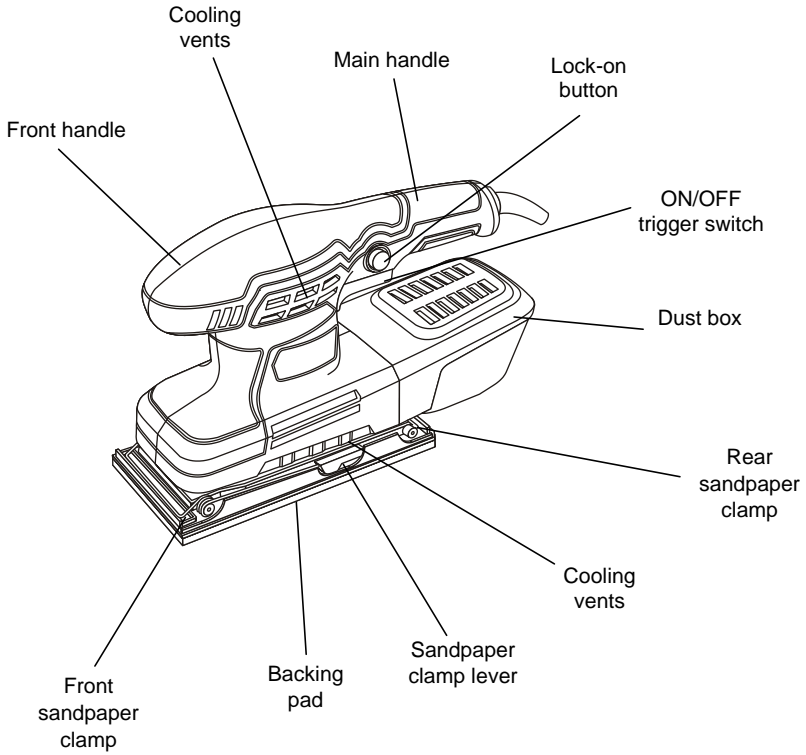

Sandpaper punch plate

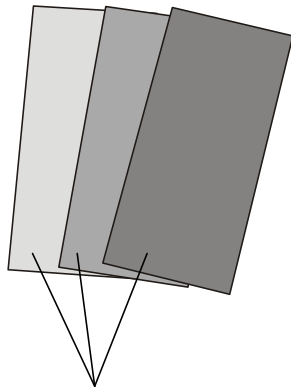

Sandpaper  
1 ea 60/80/120 grit

# ASSEMBLY AND OPERATING

## INSTALLING SANDPAPER

**▲ WARNING:** Unplug the sander from the power source before installing or changing sandpaper.

1. Lift upward and outward on the sandpaper clamp levers (1) located at each side of the sander base (2) (Fig. 1). This will release the sandpaper clamps (3) that are located at the front and rear of the sander base.

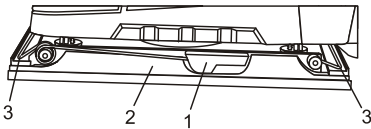

Fig. 1

2. Insert one end of the 1/3 sheet sandpaper (4) with its grit side up into the open front sandpaper clamp (5), making sure it is aligned with the backing pad (Fig. 2). Lift the sandpaper clamp lever upward and inward to lock the sandpaper into clamp.

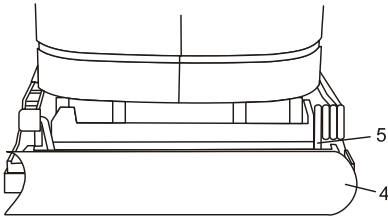

Fig. 2

3. Wrap the sandpaper sheet (4) over backing pad (6) and insert it into the open rear sandpaper clamp (7) (Fig. 3).  
**NOTE:** Make sure the sandpaper is pulled tightly over the backing pad for proper sanding operation.
4. Lift the sandpaper clamp lever up and inward to lock the sandpaper into clamp.

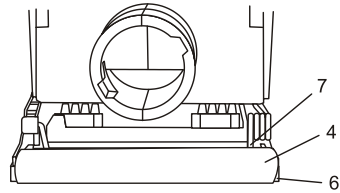

Fig. 3

## PUNCHING HOLES IN SANDPAPER

When new sandpaper is installed on the sander, place the corner of the sander base into the sandpaper hole punch with the base plate corner (1) nested into the corner of the hole punch (2). Press the base plate firmly into the hole punch. The sharp pins (3) will pierce the sandpaper (4) to allow it to extract the sanding dust.

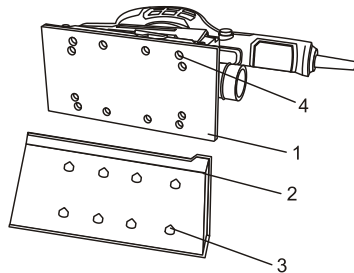

Fig. 4

## ON/OFF TRIGGER SWITCH

To turn the sander ON, squeeze the trigger switch (1) Fig. 5). To turn the sander OFF, release the trigger switch.

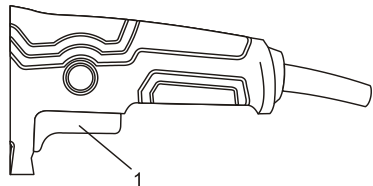

Fig. 5

# ASSEMBLY AND OPERATING

## LOCK-ON BUTTON

Your sander is equipped with a lock-on feature, which is convenient when continuously sanding for extended periods of time is required (Fig. 6). To lock the switch ON, depress the trigger switch (1), push in and hold the lock-on button (2) located at the left side of the handle, then release the trigger. Release the lock-on button and your sander will continue running. To turn the sander OFF, depress and release the trigger switch to release the lock-on button.

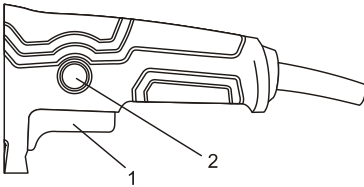

Fig. 6

### **⚠ WARNING**

For safety reasons, the operator must read the sections of this Owner's Manual entitled "GENERAL SAFETY WARNINGS", "POWER TOOL SAFETY", "SPECIFIC SAFETY RULES", "EXTENSION CORD SAFETY" and "SYMBOLS" before using this sander.

Verify the following every time the sander is used:

1. Sandpaper is in good condition and properly installed on the sander.
2. The workpiece is properly secured and free from any foreign objects.
3. Safety glasses, safety goggles, or face shield is being worn.
4. Hearing protection and dust mask are being worn.

Failure to adhere to these safety rules can greatly increase the chances of serious injury.

## SANDPAPER SELECTION

Selecting the correct grit and type of sandpaper is extremely important in achieving a high quality sanded finish. Aluminum oxide, silicon carbide and other synthetic abrasives are best for power sanding. Natural abrasives such as flint and garnet are too soft for economical use in power sanding.

In general, coarse grit will remove most material. Fine grit will produce the best finish in all sanding operations. The condition of the surface to be sanded will determine which grit will do the best job.

**NOTE:** Where the sandpaper grits are shown numerically, higher numbers indicate finer grit and lower numbers indicate coarser grit.

If the surface is rough, start with a coarse grit and sand until the surface is uniform. Medium grit may then be used to remove scratches left by the coarser grit. Fine grit should be used for finishing the surface. Always continue sanding with each grit until the surface is uniform.

## SANDING

Clamp or otherwise secure your workpiece to prevent it from moving under the sander while being sanded. Secure the workpiece in a vice if possible.

**⚠ WARNING:** Any unsecured workpiece could be thrown toward the operator causing injury.

Place the sander on the workpiece so the complete sanding pad surface is in contact with the workpiece. Turn the sander ON by squeezing the trigger switch. Move the sander slowly over the workpiece making successive passes in parallel lines. When sanding wood, make sure you move the sander parallel to the grain and not across the grain. This will make finish sanding more efficient and smoother.

# ASSEMBLY AND OPERATING

## SANDING – cont'd

Upon completion of the sanding operation, turn sander OFF by squeezing and releasing the switch trigger. Wait until the sanding disc comes to a complete stop before removing it from the workpiece.

**▲ WARNING:** Your sander should only be turned ON when the entire surface of the sanding pad is in contact with the workpiece. Failure to follow this sanding procedure could result in loose sandpaper which could result in possible injury.

**NOTE:** Hold the sander with two hands, using both the front and main handles. Be careful NOT to cover the motor cooling vents with your hands. Covering the cooling vents could cause the motor to be damaged by overheating.

**DO NOT FORCE THE SANDER.** The weight of the sander usually provides adequate pressure. Let the sander and sandpaper do the work. Applying added pressure will slow the motor, increase the wear on the sandpaper and greatly reduce sander speed. Excessive pressure will overload the motor causing possible damage from the motor overheating. It will also create an inferior finish on sanded work. Any finish or resin on wood will soften from the frictional heat, causing sandpaper to become clogged quickly. Do not sand in one spot too long as the sander's rapid action may remove too much material, making the surface uneven.

Extended periods of sanding may tend to overheat the motor. If this occurs, turn sander OFF, wait until the sanding pad comes to a complete stop and remove it from the workpiece. Check to make sure your hands have not been covering the cooling vents. Let the motor cool before continuing sanding operation.

## CLEANING THE DUST BOX

The dust box will collect much of the sanding dust that is generated during sanding operations. As a result, it must be cleaned out periodically so the dust collection will be efficient.

1. Squeeze the sides of the dust box (1) and pull it away from the rear of the sander (2) (Fig. 7).

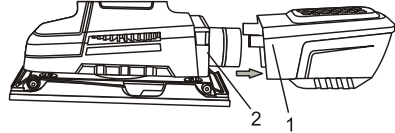

Fig. 7

2. Pry the top of the dust box (3) away from the bottom of the dust box (4) (Fig. 8).  
**NOTE:** It is best to perform this function either outside or over a trash can, as loose dust will come out of the dust box very easily.
3. Shake all the dust out of the dust box.
4. Use a soft DRY brush to remove the dust from the filter located inside the top of the dust box.
5. Once all the sanding dust is removed from the dust box, press the upper and lower sections together. They will "snap" into place when properly assembled.
6. Reinstall the dust box onto the rear of the sander.  
**NOTE:** The locking tabs (5) will "snap" into place when the dust box is fully pushed onto the rear of the sander.

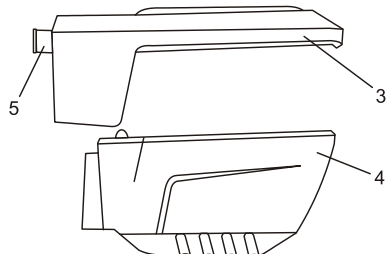

Fig. 8

# MAINTENANCE

## GENERAL

**▲ WARNING: When servicing, use only identical replacement parts. The use of any other part may create a hazard or cause product damage.**

DO NOT use solvents when cleaning plastic parts. Plastics are susceptible to damage from various types of commercial solvents and may be damaged by their use. Use a clean cloth to remove dirt, dust, oil, grease etc.

**▲ WARNING: Do not allow brake fluids, gasoline, petroleum-based products, penetrating oils, etc. to come into contact with plastic parts. They contain chemicals that can damage, weaken or destroy plastic.**

DO NOT abuse power tools. Abusive practices can damage the tool and the workpiece.

**▲ WARNING: DO NOT attempt to modify tools or create accessories. Any such alteration or modification is misuse and could result in a hazardous condition leading to possible serious injury. It will also void the warranty.**

It has been found that electric tools are subjected to accelerated wear and possible premature failure when they are used on fiberglass boats and sports cars, wallboard, spackling compounds or plaster. The chips and grindings from these materials are highly abrasive to electric tool parts such as bearings, brushes, commutators, etc. Consequently, it is not recommended that this tool be used for extended work on any fiberglass material, wallboard, spackling compounds or plaster. During any use on these materials it is extremely important that the tool is cleaned frequently by blowing it out with an air jet.

**▲ WARNING: Always wear safety goggles or safety glasses with side shields during all sanding operations. It is critical that you also wear safety goggles or safety glasses with side shields and a dust mask while blowing dust out of the sander with an air jet. Failure to take these safety precautions could result in permanent eye or lung damage.**

## LUBRICATION

All of the bearings in this tool are lubricated with a sufficient amount of high-grade lubricant for the life of the unit under normal conditions. Therefore, no further lubrication is required.

# EXPLODED VIEW

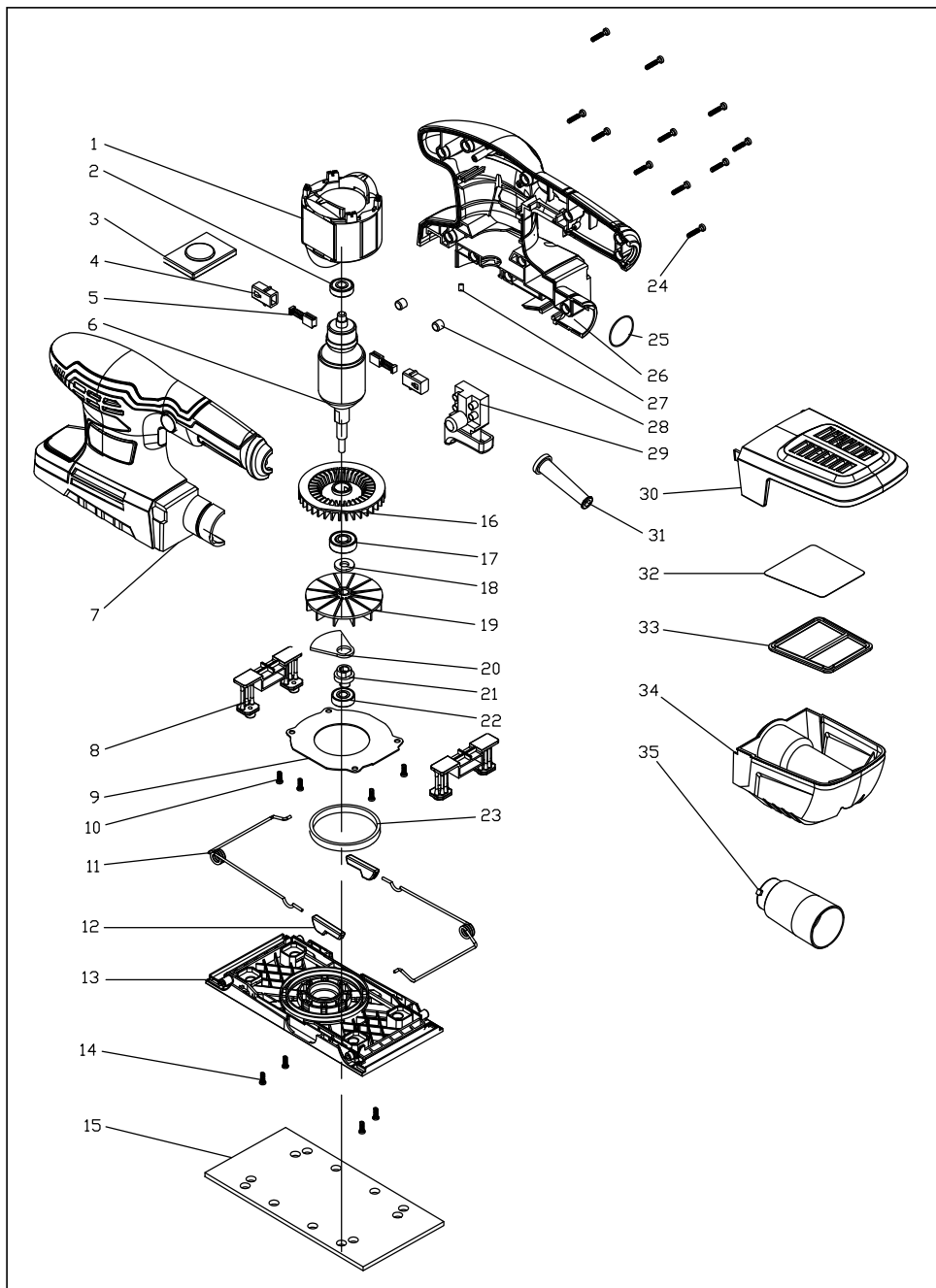

# PARTS LIST

**▲ WARNING:** When servicing, use only original equipment replacement parts. The use of any other parts may create a safety hazard or cause damage to the sander.

Any attempt to repair or replace electrical parts on this sander may create a safety hazard unless repairs are performed by a qualified technician. For more information, call the Toll-free Helpline, at 1-866-349-8665 Monday – Friday from 9am to 5pm Eastern Standard Time.

**Always order by PART NUMBER, not by key number.**

Key #	Part #	Part Name	Quantity
1	1020050059	Stator	1
2	4010010053	Bearing 607	1
3	3150210011	Bearing block	1
4	3150060021	Brush holder	2
5	1230010090	Carbon brush	2
6	1010050061	Rotor	1
7	3011050053	Housing - left	1
8	3150110017	Oscillating bracket	2
9	2030030041	Dust box cover	1
10	4030010179	Tapping screw	4
11	2050080184	Paper clamp	2
12	3120100052	Paper clamp lever	2
13	3150120028	Aluminum pad	1
14	4030010096	Tapping screw	4
15	1150020024	Backing pad	1
16	3150010029	Fan	1
17	4010010048	Bearing 608	1
18	2030020160	Washer	1
19	3150010088	Fan	1
20	2030030221	Counter balance	2
21	2010130036	Eccentric	2
22	4010010105	Bearing 609 2RS	2
23	3190010009	Felt seal	1
24	4030010106	Tapping screw ST3.9*19	1
25	3140020046	"O" ring	1
26	3011050053	Housing - right	1
27	3140060002	Vibration dampener	1
28	3140060001	Rubber cap	2
29	3140010075	Switch	1
30	3180030025	Dust collection box cover	1
31	1061260001	Cord guard	1
32	3190110005	Filter	1
33	3180060021	Filter clamp	1
34	3180020038	Dust collection box	1
35	3180040021	Rubber dust duct	1



## **PERFORMAX® 1/3 SHEET SANDER WARRANTY**

### **30-DAY MONEY BACK GUARANTEE:**

This PERFORMAX® brand power tool carries our 30-Day Money Back Guarantee. If you are not completely satisfied with your PERFORMAX® brand power tool for any reason within thirty (30) days from the date of purchase, return the tool with your original receipt to any MENARDS® retail store, and we will provide you a refund – no questions asked.

### **2-YEAR LIMITED WARRANTY:**

This PERFORMAX® brand power tool carries a 2-Year Limited Warranty to the original purchaser. If, during normal use, this PERFORMAX® power tool breaks or fails due to a defect in material or workmanship within two (2) years from the date of original purchase, simply bring this tool with the original sales receipt back to your nearest MENARDS® retail store. At its discretion, PERFORMAX® agrees to have the tool or any defective part(s) repaired or replaced with the same or similar PERFORMAX® product or part free of charge, within the stated warranty period, when returned by the original purchaser with original sales receipt. Notwithstanding the foregoing, this limited warranty does not cover any damage that has resulted from abuse or misuse of the Merchandise. This warranty: (1) excludes expendable parts including but not limited to blades, brushes, belts, bits, light bulbs, and/or batteries; (2) shall be void if this tool is used for commercial and/or rental purposes; and (3) does not cover any losses, injuries to persons/property or costs. This warranty does give you specific legal rights and you may have other rights, which vary from state to state. Be careful, tools are dangerous if improperly used or maintained. Seller's employees are not qualified to advise you on the use of this Merchandise. Any oral representation(s) made will not be binding on seller or its employees. The rights under this limited warranty are to the original purchaser of the Merchandise and may not be transferred to any subsequent owner. This limited warranty is in lieu of all warranties, expressed or implied including warranties or merchantability and fitness for a particular purpose. Seller shall not be liable for any special, incidental, or consequential damages. The sole exclusive remedy against the seller will be for the replacement of any defects as provided herein, as long as the seller is willing or able to replace this product or is willing to refund the purchase price as provided above. For insurance purposes, seller is not allowed to demonstrate any of these power tools for you.

For questions / comments, technical assistance or repair parts –  
Please Call Toll Free at: 1-866-349-8665 (M-F 9am – 5pm)

**SAVE YOUR RECEIPTS. THIS WARRANTY IS VOID WITHOUT THEM.**

Distributed by: Menard, Inc., Eau Claire, WI 54703