

MASTERFORCE®

12A ORBITAL ACTION RECIPROCATING SAW

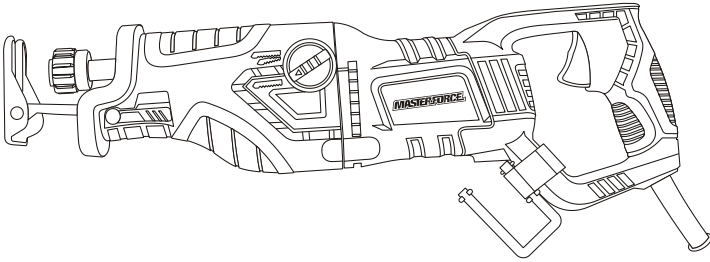

241-0752

For questions/comments, technical assistance or repair parts –
Please call toll free: 1-866-349-8665 (M–F 9am–5pm EST)

OPERATOR'S MANUAL

⚠ CAUTION: To Reduce The Risk Of Injury, User Must Read And Understand Operator's Manual. Save These Instructions For Future Reference.

TABLE OF CONTENTS

Product specifications	1
Table of contents	2
General safety warnings	3–4
Eye, ear & lung protection	3–4
Electrical safety	4
Power tool safety	5–6
General safety rules	5
Work area	5
Electrical safety	5
Personal safety	5–6
Power tool use and care.....	6
Service	6
Specific safety rules	7
Extension cord safety	8
Product specifications	9
Symbols	10
Know your reciprocating saw	11
Assembly and operating	12–15
Installing a blade	12
Removing a blade	12
Adjusting the pivoting shoe	12
Orbital control knob	13
Variable speed trigger switch	13
Variable speed adjusting knob	13
Materials you can cut	13
Cutting wood	14
Plunge cutting	14–15
Metal cutting	15
Maintenance	16–17
Replacing carbon motor brushes	17
Exploded view	18
Parts listing	19–21
Warranty	23

GENERAL SAFETY WARNINGS



WARNING: Before using this tool or any of its accessories, read this manual and follow all Safety Rules and Operating Instructions. The important precautions, safeguards and instructions appearing in this manual are not meant to cover all possible situations. It must be understood that common sense and caution are factors which cannot be built into the product.

This instruction manual includes the following:

- General Safety Rules
- Specific Safety Rules and Symbols
- Functional Description
- Assembly
- Operation
- Maintenance
- Accessories

EYE, EAR & LUNG PROTECTION



ALWAYS WEAR EYE PROTECTION THAT CONFORMS WITH CSA REQUIREMENTS or ANSI SAFETY STANDARD Z87.1

FLYING DEBRIS can cause permanent eye damage. Prescription eyeglasses ARE NOT a replacement for proper eye protection.



WARNING: Non-compliant eyewear can cause serious injury if broken during the operation of a power tool.



WARNING: Use hearing protection, particularly during extended periods of operation of the tool, or if the operation is noisy.

SAVE THESE INSTRUCTIONS FOR REFERENCE

GENERAL SAFETY WARNINGS



WEAR A DUST MASK THAT IS DESIGNED TO BE USED WHEN OPERATING A POWER TOOL IN A DUSTY ENVIRONMENT.



WARNING: Dust that is created by power sanding, sawing, grinding, drilling, and other construction activities may contain chemicals that are known to cause cancer, birth defects, or other genetic abnormalities. These chemicals include:

Lead from lead-based paints
Crystalline silica from bricks, cement, and other masonry products
Arsenic and chromium from chemically treated lumber

The level of risk from exposure to these chemicals varies, according to how often this type of work is performed. In order to reduce exposure to these chemicals, work in a well-ventilated area, and use approved safety equipment, such as a dust mask that is specifically designed to filter out microscopic particles.

ELECTRICAL SAFETY



WARNING: To avoid electrical hazards, fire hazards or damage to the tool, use proper circuit protection.

This tool is wired at the factory for 120V AC operation. It must be connected to a 120V AC, 15 A circuit that is protected by a time-delayed fuse or circuit breaker. To avoid shock or fire, replace power cord immediately if it is worn, cut or damaged in any way.

SAVE THESE INSTRUCTIONS FOR REFERENCE

POWER TOOL SAFETY

▲ WARNING: Read all safety warnings and instructions. Failure to follow the warnings and instructions may result in electric shock, fire and/or serious injury.

Save all warnings and instructions for future reference.

Work area safety

Keep work area clean and well lit. Cluttered or dark areas invite accidents.

Do not operate power tools in explosive atmospheres, such as in the presence of flammable liquids, gases or dust. Power tools create sparks which may ignite the dust or fumes.

Keep children and bystanders away while operating a power tool. Distractions can cause you to lose control.

Electrical safety

Power tool plugs must match the outlet. Never modify the plug in any way. Do not use any adapter plugs with earthed (grounded) power tools. Unmodified plugs and matching outlets will reduce risk of electric shock.

Avoid body contact with earthed or grounded surfaces such as pipes, radiators, ranges and refrigerators. There is an increased risk of electric shock if your body is earthed or grounded.

Do not expose power tools to rain or wet conditions. Water entering a power tool will increase the risk of electric shock.

Do not abuse the cord. Never use the cord for carrying, pulling or unplugging the power tool. Keep cord away from heat, oil, sharp edges or moving parts. Damaged or entangled cords increase the risk of electric shock.

When operating a power tool outdoors, use an extension cord suitable for outdoor use. Use of a cord suitable for outdoor use reduces the risk of electric shock.

If operating a power tool in a damp location is unavoidable, use a residual current device (RCD) protected supply. Use of a ground fault circuit interrupter (GFCI) reduces the risk of electric shock.

Personal safety

Stay alert, watch what you are doing and use common sense when operating a power tool. Do not use a power tool while you are tired or under the influence of drugs, alcohol or medication. A moment of inattention while operating power tools may result in serious personal injury.

Use personal protective equipment. Always wear eye protection. Protective equipment such as dust mask, non-skid safety shoes, hard hat, or hearing protection used for appropriate conditions will reduce personal injuries.

Prevent unintentional starting. Ensure the switch is in the off-position before connecting to power source and/or battery pack, picking up or carrying the tool. Carrying power tools with your finger on the switch or energizing power tools that have the switch on invites accidents.

Remove any adjusting key or wrench before turning the power tool on. A wrench or a key left attached to a rotating part of the power tool may result in personal injury.

Do not overreach. Keep proper footing and balance at all times. This enables better control of the power tool in unexpected situations.

SAVE THESE INSTRUCTIONS FOR REFERENCE

POWER TOOL SAFETY

Dress properly. Do not wear loose clothing or jewelry. Keep your hair, clothing and gloves away from moving parts. Loose clothes, jewelry or long hair can be caught in moving parts.

If devices are provided for the connection of dust extraction and collection facilities, ensure these are connected and properly used. Use of dust collection can reduce dust-related hazards.

Power tool use and care

Do not force the power tool. Use the correct power tool for your application. The correct power tool will do the job better and safer at the rate for which it was designed.

Do not use the power tool if the switch does not turn it on and off. Any power tool that cannot be controlled with the switch is dangerous and must be repaired.

Disconnect the plug from the power source and/or the battery pack from the power tool before making any adjustments, changing accessories, or storing power tools. Such preventive safety measures reduce the risk of starting the power tool accidentally.

Store idle power tools out of the reach of children and do not allow persons unfamiliar with the power tool or these instructions to operate the power tool. Power tools are dangerous in the hands of untrained users.

Maintain power tools. Check for misalignment or binding of moving parts, breakage of parts and any other condition that may affect the power tool's operation. If damaged, have the power tool repaired before use. Many accidents are caused by poorly maintained power tools.

Keep cutting tools sharp and clean. Properly maintained cutting tools with sharp cutting edges are less likely to bind and are easier to control.

Use the power tool, accessories and tool bits etc. in accordance with these instructions, taking into account the working conditions and the work to be performed. Use of the power tool for operations different from those intended could result in a hazardous situation.

Hold power tool by insulated gripping surfaces when performing an operation where the cutting tool may contact hidden wiring or its own cord. Contact with a "live" wire will make exposed metal parts of the tool "live" and shock the operator.

Use clamps or another practical way to secure and support the workpiece to a stable platform. Holding the work by hand or against your body leaves it unstable and may lead to loss of control.

Service

Have your power tool serviced by a qualified repair person using only identical replacement parts. This will ensure that the safety of the power tool is maintained.

SAVE THESE INSTRUCTIONS FOR REFERENCE

SPECIFIC SAFETY RULES

⚠ WARNING: Know your reciprocating saw. Do not plug in the tool until you have read and understand this Instruction Manual. Learn the tool's applications and limitations, as well as the specific potential hazards related to this tool. Following this rule will reduce the risk of electric shock, fire, or serious injury.



Always wear eye protection. Any power tool can throw foreign objects into your eyes and cause permanent eye damage.

ALWAYS wear safety goggles (not glasses) that comply with ANSI safety standard Z87.1. Everyday glasses have only impact resistant lenses. They ARE NOT safety glasses.

⚠ WARNING: Glasses or goggles not in compliance with ANSI Z87.1 could cause serious injury when they break.

⚠ WARNING: Always use hearing protection when sawing, particularly during extended periods of operation.

⚠ WARNING: Always unplug the tool from the power source before changing the blade and when making any adjustments.

Do not wear gloves, neckties or loose clothing.

Hold the tool by its insulated gripping surfaces when performing an operation where the saw blade may contact hidden wiring or its own cord. Contact with a "live" wire will make exposed metal parts of the tool "live" and shock the operator.

Always hold the tool with two hands. Attempting to control the tool with only one hand is dangerous. It could result in loss of control and serious injury.

Never hold the workpiece in one hand and the tool in the other hand when sawing. Never place the hands near or below the cutting surface. Clamp the workpiece and guide the tool with both hands.

Always make sure the work surface is free from nails and other foreign objects. Cutting into a nail can cause the blade and the tool to jump and damage the blade.

Never lay the workpiece on hard surfaces like concrete, stone, etc. The protruding blade may cause tool to jump.

After changing a blade or making adjustments, make sure the blade clamp is holding the blade securely. Loose blades could be violently thrown from the tool.

Never use dull or damaged blades. Sharp blades must be handled with care. Damaged blades can snap during use. Dull blades require more force to cut the workpiece, possibly causing the blade to break.

Never touch the blade during or immediately after use. After use the blade is too hot to be touched.

SAVE THESE INSTRUCTIONS FOR REFERENCE

EXTENSION CORD SAFETY

⚠ WARNING: Keep the extension cord clear of the working area. Position the cord so it will not get caught on the workpiece, tools or any other obstructions while you are working with the power tool.

Make sure any extension cord used with this tool is in good condition. When using an extension cord, be sure to use one of heavy enough gauge to carry the current the tool will draw. An undersized cord will cause a drop in line voltage resulting in loss of power and overheating.

The table at right shows the correct size to use according to cord length and nameplate ampere rating. If in doubt, use the next heavier gauge. The smaller the gauge number the heavier the cord.

Be sure your extension cord is properly wired and in good condition. Always replace a damaged extension cord or have it repaired by a qualified electrician before using it. Protect your extension cord from sharp objects, excessive heat and damp or wet areas.

Use a separate electrical circuit for your power tools. This circuit must not be less than 14 gauge wire and should be protected with either a 15 AMP time delayed fuse or circuit breaker. Before connecting the power tool to the power source, make sure the switch is in the OFF position and the power source is the same as indicated on the nameplate. Running at lower voltage will damage the motor.

⚠ WARNING: Repair or replace damaged or worn extension cords immediately.

Select the appropriate extension cord gauge and length using the chart below.

When operating a power tool outdoors, use an outdoor extension cord marked "W-A" or "W". These cords are rated for outdoor use and reduce the risk of electric shock.

⚠ WARNING: Keep the extension cord clear of the working area. Position the cord so it will not get caught on the workpiece, tools or any other obstructions while you are working with the power tool.

MINIMUM GAUGE (AWG) EXTENSION CORDS (120V use only)					
Amperage rating		Total length			
More than	Not more than	25' (7.5 m)	50' (15 m)	100' (30 m)	150' (45 m)
0	6	18	16	16	14
6	10	18	16	14	12
10	12	16	16	14	12
12	16	14	12	Not Applicable	

SAVE THESE INSTRUCTIONS FOR REFERENCE

PRODUCT SPECIFICATIONS

Rating:	120V, 60Hz, AC
Amperes:	12 AMP
Speed:	0–2,800 SPM (no load)
Stroke Length:	1 1/4"
Maximum cutting depth in wood:	4 1/2"
Maximum cutting depth in steel:	19/32"
Maximum cutting depth in pipe:	1 1/2"
Blade change system:	Tool-less
Weight:	12.18 lb

Need Assistance?





Call us on our toll free customer support line:











1-866-349-8665

- Technical questions
- Replacement parts
- Parts missing from package

SYMBOLS

▲ WARNING: Some of the following symbols may appear on the reciprocating saw. Study these symbols and learn their meaning. Proper interpretation of these symbols will allow for more efficient and safer operation of this tool.

V	Volts
A	Amperes
Hz	Hertz
W	Watts
kW	Kilowatts
μF	Microfarads
L	Liters
kg	Kilograms
H	Hours
N/cm ²	Newtons per square centimeter
Pa	Pascals
OPM	Oscillations per minute
Min	Minutes
S	Seconds
 or a.c.	Alternating current
	Three-phase alternating current
	Three-phase alternating current with neutral
	Direct current

	No load speed
	Alternating or direct current
	Class II construction
	Splash-proof construction
	Watertight construction
	Protective grounding at grounding terminal, Class I tools
.../min	Revolutions or reciprocations per minute
∅	Diameter
0	Off position
	Arrow
	Warning symbol
	Wear your safety glasses
	Wear a dust mask
	Wear hearing protection



This symbol designates that this tool is listed with U.S. requirements by ETL Testing Laboratories, Inc. Conforms to UL Std. 60745-1 and 60745-2-11. Certified to CAN/CSA Std. C22.2 No. 60745-1 and 60745-2-11.

KNOW YOUR RECIPROCATING SAW

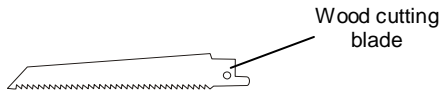
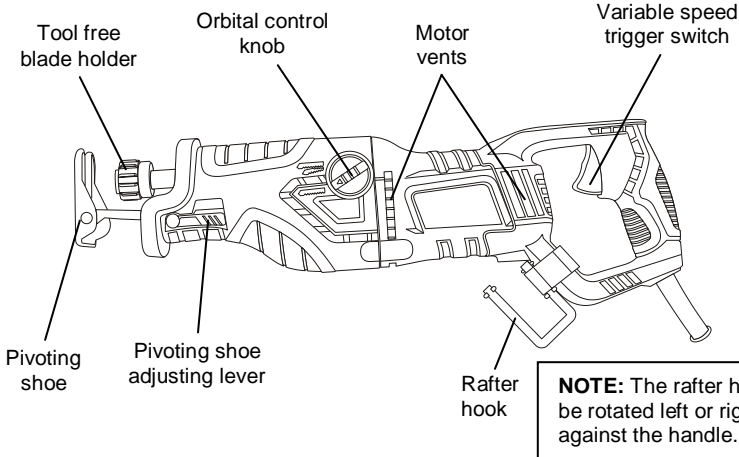

NOTE: This reciprocating saw has a built in anti-vibration system that is automatically functioning when the tool is turned ON. This anti-vibration system reduces fatigue during extended periods of use and enhances your ability to control the tool.

⚠ WARNING: Use only universal fitting reciprocating saw blades that are designed for the material being cut. Inappropriate blades may bend or shatter causing serious personal injury.

ASSEMBLY AND OPERATING

INSTALLING A BLADE

⚠ WARNING: Always remove the plug from the power source before installing or removing a blade or adjusting the saw in any way.

1. To install a blade in the saw, rotate the blade locking sleeve (1) counter clockwise (Fig. 1).
2. Insert the appropriate blade (2) into the blade slot (3) as far as it will go.
3. Release the blade locking sleeve.

NOTE: The blade will automatically be locked into the blade holder. Pull outward on the blade to ensure it is properly locked into the blade holder.

REMOVING A BLADE

To remove a blade, simply rotate the blade locking sleeve counter clockwise and remove the blade from the blade holder.

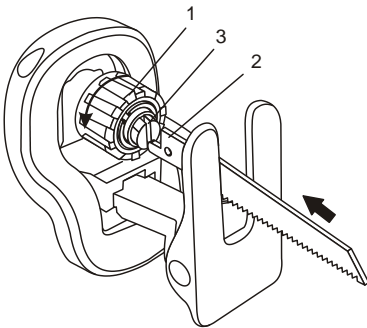

Fig. 1

ADJUSTING THE PIVOTING SHOE

The pivoting shoe will pivot to follow the angle of the blade to the workpiece. This action ensures the flat surface of the shoe is against the workpiece for better cutting action and easier control of the saw.

The shoe can be adjusted in or out, allowing the use of the blade teeth at different points on the blade. This will provide longer blade life as one section of the blade becomes dull.

1. To adjust the pivoting shoe (1), rotate the pivoting shoe adjusting lever (2) to its downward position (3) (Fig. 2).
2. Slide the pivoting shoe in or out until it is in the appropriate position.
3. Lock the pivoting shoe in place by rotating the pivoting shoe adjusting lever upward to its original horizontal position.
4. Pull outward on the pivoting shoe to ensure it is firmly locked in place.

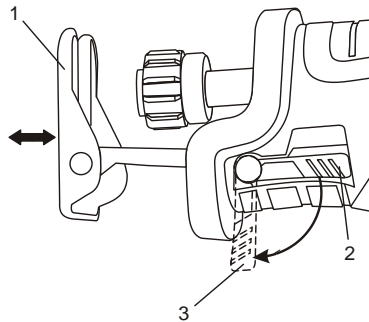

Fig. 2

ASSEMBLY AND OPERATING

ORBITAL CONTROL KNOB

This reciprocating saw has two cutting actions. The conventional reciprocating action produces a smoother cut with less splintering. The orbital reciprocating action is more aggressive and produces rougher cuts.

To operate the saw in conventional cutting mode, rotate the orbital control knob (1) counter clockwise (Fig. 3). To operate the saw in orbital cutting mode, rotate the orbital control knob clockwise (2).

▲ WARNING: Always remove the plug from the power source when changing the orbital control knob. Changing the orbital control knob with the saw operating may cause serious personal injury and damage the saw.

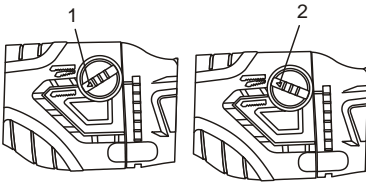

Fig. 3

VARIABLE SPEED TRIGGER SWITCH

The variable speed trigger switch controls both the ON/OFF function and the speed of the tool.

1. To turn the saw ON, squeeze the switch trigger (1) slightly (Fig. 4).
NOTE: The saw will start at its slowest speed.
2. To increase the speed of the saw, squeeze the switch trigger harder.
NOTE: When the switch trigger is squeezed fully, the saw will run at its maximum speed.
3. To turn the saw OFF, release the switch trigger.

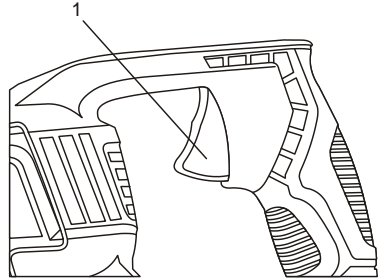

Fig. 4

MATERIALS YOU CAN CUT

This reciprocating saw is a versatile tool that allows you to cut many different types of materials. Some of these materials include:

- Wood products such as lumber, hardwood, plywood, composite board, and paneling
- Drywall
- Fiber board and plastic
- Metals, such as pipe, steel rods, sheet steel, aluminum, brass, and copper.

NOTE: There are many different types of blades available. Generally, there are metal cutting blades (fine teeth) and wood cutting blades (coarse teeth). Use the correct blade for your application. The packaging on the blade will indicate the type of materials each blade is designed to cut

ASSEMBLY AND OPERATING

⚠ WARNING

For safety reasons, the operator must read the sections of this Owner's Manual entitled "GENERAL SAFETY WARNINGS", "POWER TOOL SAFETY", "SPECIFIC SAFETY RULES", "EXTENSION CORD SAFETY" and "SYMBOLS" before using this reciprocating saw.

Verify the following every time the reciprocating saw is used:

1. The correct blade for the material being cut is installed in the saw.
2. The blade is firmly clamped in the blade holder.
3. The blade is sharp and in good condition.
4. The workpiece is properly secured.
5. Safety glasses and hearing protection are being worn.

Failure to observe these safety rules will significantly increase the risk of injury.

5. Hold the saw away from your body and in front of you (Fig. 5).
6. With both hands firmly gripping the saw, and with the blade NOT in contact with the surface to be cut, start the saw by squeezing the switch trigger.
7. Once the saw has reached the desired speed, place the adjustable pivoting shoe against the workpiece and gradually bring the moving blade into contact with the workpiece at the appropriate location.

⚠ CAUTION: Do not force the saw. Use only enough force to keep the blade cutting. Excessive pressure on the blade will cause it to bend and twist, which may result in breaking the blade.

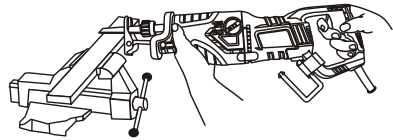

Fig. 5

CUTTING WOOD

Fig. 6

1. Clearly mark the workpiece to locate the position of the cut.
2. Hold smaller workpieces with a vice. Clamp larger workpieces to a workbench or table.

⚠ DANGER: Any workpiece that is not adequately clamped in place may come loose and cause serious injury. Never hold the workpiece with your hand.

3. Make sure there are no nails, screws, clamps or foreign materials in the path of the saw blade.
4. Set the orbital control knob to either conventional or orbital cutting to produce the desired cutting effect (Fig. 3).

PLUNGE CUTTING

1. Clearly mark the workpiece to locate the position of the cut.
2. Clamp the workpiece to a workbench or table (Fig. 6).

NOTE: Make sure the area to be cut is clear under the workpiece so that the blade will not come into contact with anything other than the workpiece.

3. Set the orbital control knob to conventional cutting (Fig. 3).

⚠ WARNING: Never set the orbital control knob to orbital setting when plunge cutting. If you do, blades may bend or break and serious injury may result.

ASSEMBLY AND OPERATING

PLUNGE CUTTING – cont'd

4. Select a convenient starting point in the area to be cut out. Place the tip of the blade over that point.
5. Rest the lower edge of the adjustable pivoting shoe on the workpiece and hold it firmly in that position, maintaining a shallow cutting angle.
6. Squeeze the switch trigger to start the saw.
▲ WARNING: Make sure the blade does not touch the workpiece until the saw reaches full speed. Loss of control and possible injury could result.
7. With the saw running at full speed, slowly tilt the saw until the tip of the blade contacts the workpiece and begins to cut. After the blade cuts through the workpiece, tilt the saw upward until the blade is perpendicular to the workpiece.

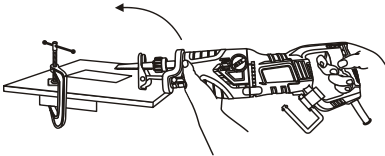

Fig. 6

METAL CUTTING

Metals such as pipe, steel rods, sheet steel, aluminum, brass and copper can be cut with your reciprocating saw (Fig. 7).

Set the orbital control knob to conventional cutting (Fig. 3).

▲ WARNING: Never set the orbital control knob to orbital setting when plunge cutting. If you do, blades may bend or break and serious injury may result.

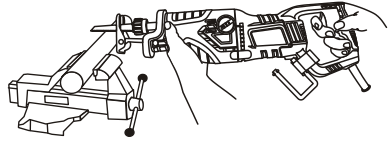

Fig. 7

- To cut thin sheet material, "sandwich" the material between hardboard or plywood and clamp the layers to limit vibration and material tearing.
- Always use a fine toothed metal cutting blade and run the saw at medium speeds when cutting metal.
- Use cutting oil to keep the blade cool, increase cutting action, and prolong the life of the blade.
- Do not twist or bend the saw blade.
- Do not force the saw blade. Let it cut at its own speed.

▲ DANGER:

- a) **Always clamp the workpiece in a vice, or to a workbench or table. Do not hold the workpiece in your hand.**
- b) **Never use gasoline as a lubricant or as a cleaning agent. A spark from the motor may cause an explosion. Gasoline will also damage the plastic components of the saw.**

MAINTENANCE

GENERAL

⚠ WARNING: When servicing, use only identical replacement parts. The use of any other part may create a hazard or cause product damage.

DO NOT use solvents when cleaning plastic parts. Plastics are susceptible to damage from various types of commercial solvents and may be damaged by their use. Use a clean cloth to remove dirt, dust, oil, grease etc.

⚠ WARNING: Do not allow brake fluids, gasoline, petroleum-based products, penetrating oils, etc. to come into contact with plastic parts. They contain chemicals that can damage, weaken or destroy plastic.

DO NOT abuse power tools. Abusive practices can damage the tool and the workpiece.

⚠ WARNING: DO NOT attempt to modify tools or create accessories. Any such alteration or modification is misuse and could result in a hazardous condition leading to possible serious injury. It will also void the warranty.

It has been found that electric tools are subjected to accelerated wear and possible premature failure when they are used on fiberglass boats and sports cars, wallboard, spackling compounds or plaster. The chips and grindings from these materials are highly abrasive to electric tool parts such as bearings, brushes, commutators, etc. Consequently, it is not recommended that this tool be used for extended work on any fiberglass material, wallboard, spackling compounds or plaster. During any use on these materials it is extremely important that the tool is cleaned frequently by blowing it out with an air jet.

⚠ WARNING: Always wear safety goggles or safety glasses with side shields during all cutting operations. It is critical that you also wear safety goggles or safety glasses with side shields and a dust mask while blowing dust out of the reciprocating saw with an air jet. Failure to take these safety precautions could result in permanent eye or lung damage.

LUBRICATION

All of the bearings in this tool are lubricated with a sufficient amount of high-grade lubricant for the life of the unit under normal conditions. Therefore, no further lubrication is required.

MAINTENANCE

REPLACING CARBON MOTOR BRUSHES

The carbon motor brushes will wear down and require replacing. The time intervals between replacements will vary depending upon the working environment and the hours of use. It is recommended that the brushes be checked after each 10 hours of use. When the length of the carbon brush reaches 1/4" (6.35 mm), the brushes should be replaced.

⚠ WARNING: Unplug the tool from the power source.

1. Use a 3/16" (5 mm) slot screwdriver and remove one brush cap (1) (Fig. 8). Turn the brush cap counter-clockwise to remove it from the motor housing.
2. Pull the spring & brush assembly (2) from the brush holder (3) in the motor housing (4).
3. Insert the new spring & brush assembly into the motor housing.
4. Compress the spring into the brush holder and thread the brush cap back into the motor housing.
NOTE: Make sure the brush cap threads are not cross-threaded. Do NOT over tighten.
5. Repeat steps 1 to 4 to replace the second carbon brush located on the opposite side of the motor housing.

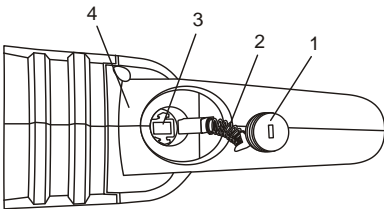
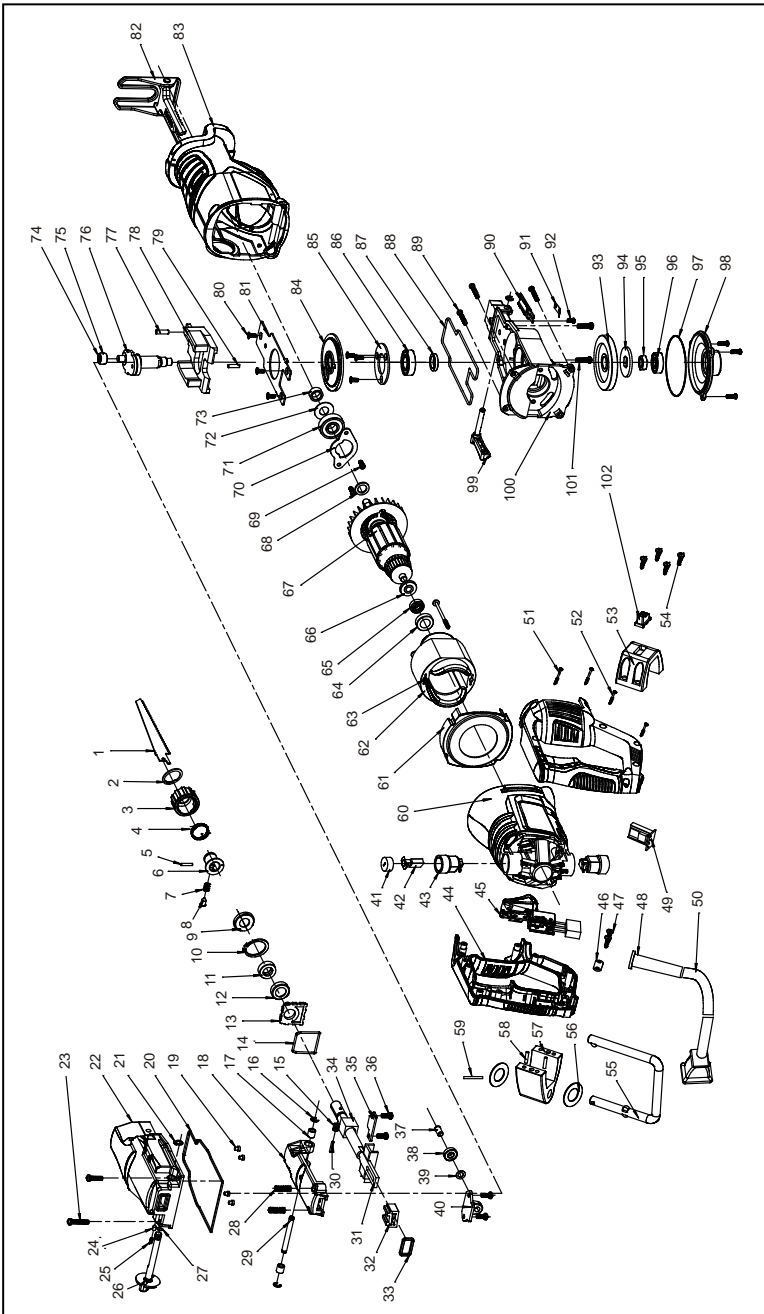

Fig. 8

EXPLODED VIEW



PARTS LIST

▲ WARNING: When servicing, use only original equipment replacement parts. The use of any other parts may create a safety hazard or cause damage to the reciprocating saw.

Any attempt to repair or replace electrical parts on this reciprocating saw may create a safety hazard unless repairs are performed by a qualified technician. For more information, call the Toll-free Helpline, at
1-866-349-8665 – Friday from 9am to 5pm Eastern Standard Time.

Always order by PART NUMBER, not by key number.

Key #	Part #	Part Name	Quantity
1	6060030005	Saw blade	1
2	2030110013	Circlip 12mm	1
3	3120060060	Blade release sleeve	1
4	2050050045	Helical spring	1
5	4110020011	Pin	1
6	2040310033	Blade holder	1
7	2050060204	Spring	1
8	2040160171	Locking pin	1
9	2040310034	Fast release collar	1
10	4100020008	Circlip	1
11	3140020124	Retaining ring	1
12	2040310043	Locating ring	1
13	3150130132	Support plate	1
14	3140020125	Sealing ring	1
15	2050060204	Spring	1
16	4100050002	Circlip 6mm	2
17	2010080122	Bearing	2
18	2020140013	Assembly protective cover	1
19	2040160185	Locating pin	1
20	3140020121	Gasket	1
21	4100020006	Shaft retainer ring	1
22	2020020047	Upper cover	1
23	4020010162	Screw	1
24	2040160190	Gear column	2
25	2050060230	Springs	2
26	1160030077	Knob	1
27	3140020123	O ring	2
28	2050060229	Helical springs	2
29	2040290082	Spindle	1
30	2040160170	Pin	1

PARTS LIST

Key #	Part #	Part Name	Quantity
31	1150010041	Reciprocating rod	1
32	2010150054	Support	1
33	3140020124	Sealing ring	1
34	2010150053	Support	1
35	2030160140	Retaining plate	1
36	4020010161	Screws M5*12	4
37	2040160188	Pin	1
38	4010010094	Bearing 697-2RS	2
39	2030020326	Flat washer 7.5*12*0.5	1
40	2010150052	Main gear edge bearing assembly	1
41	1230030028	Brush cap	2
42	1230010145	Carbon brush	2
43	1230030027	Brush holder	2
44	3120070127	Handle	1
45	1062020063	Switch	1
46	2030050002	Cord plate	1
47	4030010099	Screws ST3.9*14	4
48	3140010080	Power cord strain relief	1
49	1130030047	Heat sink	1
50	1190290014	Power cord	1
51	4030010106	Screws	6
52	4030010125	Screws	2
53	3150160208	½ Rafter hook storage	1
54	4030010099	Screw ST3.9*14	1
55	2060100075	Rafter hook	1
56	2030020327	Flat washer	1
57	3120160208	½ Rafter hook storage	1
58	2140060031	Rubber anti-vibration pins	2
59	4130010012	Plastic locating pin	1
60	3011110015	Motor housing	1
61	3150050089	Air flow guide	1
62	1020110011	Stator	1
63	4030010120	Screws ST3.9*60	2
64	3140040018	Bearing boot cover	1
65	4010010139	Bearing 698-2RS	1
66	3150240009	Flat washer	1
67	1010110013	Rotor	1
68	3190010045	Felt (oil) washer	1
69	4020010147	Screws M4*12	2
70	2030160137	Bearing retaining plate	1

PARTS LIST

Key #	Part #	Part Name	Quantity
71	4010010081	Bearing 6201-2RS	1
72	2030020325	Flat washer12.1*2.5*1	1
73	2040310041	Spacer 11.8*16.5*7	1
74	4110130001	Needle Bearings	19
75	2030270009	Sleeve	1
76	2040040104	Eccentric	1
77	2040160186	Stop/slider pins 5*15	4
78	2010130046	Anti-vibration assembly	1
79	2040160187	Pin 4*15	1
80	4020020010	Screws M4*10	8
81	2040310042	Guide	1
82	2030010061	Adjustable shoe	1
83	3160040089	Shell	1
84	2010220004	Spacer	1
85	2030160139	Bearing support plate	1
86	4010010084	Bearing 6002-RS	1
87	2010080121	O ring 22*15.2*4	1
88	3140020122	O ring	1
89	4030010114	Screws ST 3.9*25	4
90	2030160148	Plate	1
91	2030020327	Reed	1
92	4020010143	Combination screw	1
93	2040100003	Main gear	1
94	2030160138	Plastic washer	1
95	4060010028	Hexagonal nut	1
96	4010010014	Bearing 629-RS	1
97	3140020126	O ring	1
98	2020020048	Bottom cover	1
99	1160040016	Quick shoe release	1
100	2020020046	Gear box	1
101	4020010163	Combination screws M5*20	3
102	3140070024	Rubber locating block	1



12A ORBITAL ACTION RECIPROCATING SAW WARRANTY

90-DAY MONEY BACK GUARANTEE:

This MASTERFORCE® brand power tool carries our 90-Day Money Back Guarantee. If you are not completely satisfied with your MASTERFORCE® brand power tool for any reason within ninety (90) days from the date of purchase, return the tool with your original receipt to any MENARDS® retail store, and we will provide you a refund – no questions asked.

3-YEAR LIMITED WARRANTY:

This MASTERFORCE® brand power tool carries our famous No Hassle 3-Year Limited Warranty to the original purchaser. If, during normal use, this MASTERFORCE® power tool breaks or fails due to a defect in material or workmanship within three (3) years from the date of original purchase, simply bring the tool with the original sales receipt back to your nearest MENARDS® retail store. At its discretion, MASTERFORCE® agrees to have the tool or any defective part(s) repaired or replaced with the same or similar MASTERFORCE® product or part free of charge, within the stated warranty period, when returned by the original purchaser with original sales receipt. Notwithstanding the foregoing, this limited warranty does not cover any damage that has resulted from abuse or misuse of the Merchandise. This warranty: (1) excludes expendable parts including but not limited to blades, brushes, belts, bits, light bulbs, and/or batteries; (2) shall be void if this tool is used for commercial and/or rental purposes; and (3) does not cover any losses, injuries to persons/property or costs. This warranty does give you specific legal rights and you may have other rights, which vary from state to state. Be careful, tools are dangerous if improperly used or maintained. Seller's employees are not qualified to advise you on the use of this Merchandise. Any oral representation(s) made will not be binding on seller or its employees. The rights under this limited warranty are to the original purchaser of the Merchandise and may not be transferred to any subsequent owner. This limited warranty is in lieu of all warranties, expressed or implied including warranties of merchantability and fitness for a particular purpose. Seller shall not be liable for any special, incidental, or consequential damages. The sole exclusive remedy against the seller will be for the replacement of any defects as provided herein, as long as the seller is willing or able to replace this product or is willing to refund the purchase price as provided above. For insurance purposes seller is not allowed to demonstrate any of these power tools for you.

For questions / comments, technical assistance or repair parts –
Please call toll free at: **1-866-349-8665** (M-F 9am – 5pm).

**SAVE YOUR RECEIPTS
THIS WARRANTY IS VOID WITHOUT THEM**

MASTERFORCE[®]

MENARDS[®]