

Radley®

6 Amp Reciprocating Saw



Owner's Manual



Intertek
3042597
JD3507U

**READ ALL INSTRUCTIONS BEFORE FIRST USE.
KEEP THIS MANUAL FOR FUTURE REFERENCE.
KEEP AWAY FROM CHILDREN.**



**WEAR CSA
APPROVED EYE
PROTECTION**



**WEAR EAR
PROTECTION**



**WEAR A
FACE MASK**

PRODUCT SPECIFICATIONS

6 AMP RECIPROCATING SAW	
Rating	120V, 60Hz, AC
Amperes	6 AMP
Speed	0-2,800 SPM (no load)
Stroke Length	1" (26 mm)
Maximum cutting depth in wood	4" (102mm)
Maximum cutting depth in steel	1/2" (13mm)
Maximum cutting depth in pipe	1 1/4" (32mm)
Blade change system	Tool-less
Weight	6.1 lb

Need Assistance?

Call us on our toll free customer support line:

1-866-349-8665 (Monday through Friday 9am – 5pm Eastern Time)

- Technical questions
- Replacement parts
- Parts missing from package

TABLE OF CONTENTS

Product specifications	1
Table of contents	2
General safety warnings	3-4
Eye, ear & lung protection	3-4
Electrical safety	4
Power tool safety	4-6
Work area safety	5
Personal safety	5
Power tool use and care	5-6
Service	6
Specific safety rules	7-8
Extension cord safety	8
Symbols	9
Know your reciprocating saw	10
Assembly and operating	11-14
Installing a blade	11
Removing a blade	11
Adjusting the pivoting shoe	11
Variable speed trigger switch	11-12
Variable speed adjusting knob	12
Lock-on button	12
Materials you can cut	12
General cutting	13
Plunge cutting	13-14
Metal cutting	14
Maintenance	15
Exploded view	16
Parts listing	17
Warranty	18

GENERAL SAFETY WARNINGS

WARNING: Before using this tool or any of its accessories, read this manual and follow all Safety Rules and Operating Instructions. The important precautions, safeguards and instructions appearing in this manual are not meant to cover all possible situations. It must be understood that common sense and caution are factors which cannot be built into the product.

This instruction manual includes the following:

- General Safety Warnings
- Specific Safety Rules and Symbols
- Functional Description
- Assembly
- Operation
- Maintenance
- Accessories

EYE, EAR & LUNG PROTECTION



**WEAR CSA APPROVED
EYE PROTECTION**



**WEAR EAR
PROTECTION**



**WEAR A
FACE MASK**

ALWAYS WEAR EYE PROTECTION THAT CONFORMS WITH CSA REQUIREMENTS or ANSI SAFETY STANDARD Z87.1

FLYING DEBRIS can cause permanent eye damage. Prescription eyeglasses ARE NOT a replacement for proper eye protection. **WARNING:** Non-compliant eyewear can cause serious injury if broken during the operation of a power tool.

ALWAYS WEAR EAR PROTECTION

WARNING: Use hearing protection, particularly during extended periods of operation of the tool, or if the operation is noisy.

WEAR A DUST MASK THAT IS DESIGNED TO BE USED WHEN OPERATING A POWER TOOL IN A DUSTY ENVIRONMENT.

WARNING: Dust that is created by power sanding, sawing, grinding, drilling, and other construction activities may contain chemicals that are known to cause cancer, birth defects, or other genetic abnormalities. These chemicals include: Lead from lead-based paints; Crystalline silica from bricks, cement, and other masonry products; Arsenic and chromium from chemically treated lumber. The level of risk from exposure to these chemicals varies, according to how often this type of work is performed. In order to reduce exposure to these chemicals, work in a well-ventilated area, and use approved safety equipment, such as a dust mask that is specifically designed to filter out microscopic particles.

ELECTRICAL SAFETY



WARNING: To avoid electrical hazards, fire hazards or damage to the tool, use proper circuit protection.

This tool is wired at the factory for 120 V AC operation. It must be connected to a 120 V AC, 15 A circuit that is protected by a time-delayed fuse or circuit breaker. To avoid shock or fire, replace power cord immediately if it is worn, cut or damaged in any way.

Power tool plugs must match the outlet. Never modify the plug in any way. Do not use any adapter plugs with earthed (grounded) power tools. Unmodified plugs and matching outlets will reduce risk of electric shock.

Avoid body contact with earthed or grounded surfaces such as pipes, radiators, ranges and refrigerators. There is an increased risk of electric shock if your body is earthed or grounded.

Do not expose power tools to rain or wet conditions. Water entering a power tool will increase the risk of electric shock.

Do not abuse the cord. Never use the cord for carrying, pulling or unplugging the power tool. Keep cord away from heat, oil, sharp edges or moving parts. Damaged or entangled cords increase the risk of electric shock.

When operating a power tool outdoors, use an extension cord suitable for outdoor use. Use of a cord suitable for outdoor use reduces the risk of electric shock.

If operating a power tool in a damp location is unavoidable, use a residual current device (RCD) protected supply. Use of a ground fault circuit interrupter (GFCI) reduces the risk of electric shock.

POWER TOOL SAFETY

WARNING: Read all safety warnings and instructions. Failure to follow the warnings and instructions may result in electric shock, fire and/or serious injury.

Save all warnings and instructions for future reference.

WORK AREA SAFETY

Keep work area clean and well lit. Cluttered or dark areas invite accidents.

Do not operate power tools in explosive atmospheres, such as in the presence of flammable liquids, gases or dust. Power tools create sparks which may ignite the dust or fumes.

Keep children and bystanders away while operating a power tool. Distractions can cause you to lose control.

PERSONAL SAFETY

Stay alert, watch what you are doing and use common sense when operating a power tool. Do not use a power tool while you are tired or under the influence of drugs, alcohol or medication. A moment of inattention while operating power tools may result in serious personal injury.

Use personal protective equipment. Always wear eye protection. Protective equipment such as dust mask, non-skid safety shoes, hard hat, or hearing protection used for appropriate conditions will reduce personal injuries.

Prevent unintentional starting. Ensure the switch is in the off-position before connecting to power source and/or battery pack, picking up or carrying the tool. Carrying power tools with your finger on the switch or energizing power tools that have the switch on invites accidents.

Remove any adjusting key or wrench before turning the power tool on. A wrench or a key left attached to a rotating part of the power tool may result in personal injury.

Do not overreach. Keep proper footing and balance at all times. This enables better control of the power tool in unexpected situations.

Dress properly. Do not wear loose clothing or jewellery. Keep your hair, clothing and gloves away from moving parts. Loose clothes, jewellery or long hair can be caught in moving parts

If devices are provided for the connection of dust extraction and collection facilities, ensure these are connected and properly used. Use of dust collection can reduce dust-related hazards.

POWER TOOL USE AND CARE

Do not force the power tool. Use the correct power tool for your application. The correct power tool will do the job better and safer at the rate for which it was designed.

Do not use the power tool if the switch does not turn it on and off. Any power tool that cannot be controlled with the switch is dangerous and must be repaired.

Disconnect the plug from the power source and/or the battery pack from the power tool before making any adjustments, changing accessories, or storing power tools. Such preventive safety measures reduce the risk of starting the power tool accidentally.

Store idle power tools out of the reach of children and do not allow persons unfamiliar with the power tool or these instructions to operate the power tool. Power tools are dangerous in the hands of untrained users.

Maintain power tools. Check for misalignment or binding of moving parts, breakage of parts and any other condition that may affect the power tool's operation. If damaged, have the power tool repaired before use. Many accidents are caused by poorly maintained power tools.

Keep cutting tools sharp and clean. Properly maintained cutting tools with sharp cutting edges are less likely to bind and are easier to control.

SERVICE

Have your power tool serviced by a qualified repair person using only identical replacement parts. This will ensure that the safety of the power tool is maintained.



SPECIFIC SAFETY RULES

WARNING: Know your reciprocating saw. Do not plug in the tool until you have read and understand this Instruction Manual. Learn the tool's applications and limitations, as well as the specific potential hazards related to this tool. Following this rule will reduce the risk of electric shock, fire, or serious injury.



WEAR CSA APPROVED EYE PROTECTION

Always wear eye protection. Any power tool can throw foreign objects into your eyes and cause permanent eye damage. ALWAYS wear safety goggles (not glasses) that comply with CSA or ANSI safety standard Z87.1. Everyday glasses have only impact resistant lenses. They ARE NOT safety glasses

WARNING: Glasses or goggles not in compliance with ANSI Z87.1 could cause serious injury when they break.

WARNING: Always use a safety shield, hearing protection and dust mask when drilling concrete.

WARNING: Always use hearing protection when sawing, particularly during extended periods of operation.

WARNING: Always unplug the tool from the power source before changing the blade and when making any adjustments.

Do not wear gloves, neckties or loose clothing.

Hold the tool by its insulated gripping surfaces when performing an operation where the saw blade may contact hidden wiring or its own cord. Contact with a "live" wire will make exposed metal parts of the tool "live" and shock the operator.

Always hold the tool with two hands. Attempting to control the tool with only one hand is dangerous. It could result in loss of control and serious injury.

Never hold the workpiece in one hand and the tool in the other hand when sawing. Never place the hands near or below the cutting surface. Clamp the workpiece and guide the tool with both hands.

Always make sure the work surface is free from nails and other foreign objects. Cutting into a nail can cause the blade and the tool to jump and damage the blade. Never lay the workpiece on hard surfaces like concrete, stone, etc. The protruding blade may cause tool to jump.

Never lay the workpiece on hard surfaces like concrete, stone, etc. The protruding blade may cause tool to jump.

After changing a blade or making adjustments, make sure the blade clamp is holding the blade securely. Loose blades could be violently thrown from the tool.

Never use dull or damaged blades. Sharp blades must be handled with care. Damaged blades can snap during use. Dull blades require more force to cut the workpiece, possibly causing the blade to break.

Never touch the blade during or immediately after use. After use the blade is too hot to be touched.

GUIDELINES FOR EXTENSION CORDS

WARNING: Keep the extension cord clear of the working area. Position the cord so it will not get caught on the workpiece, tools or any other obstructions while you are working with the power tool.

Make sure any extension cord used with this tool is in good condition. When using an extension cord, be sure to use one of heavy enough gauge to carry the current the tool will draw. An undersized cord will cause a drop in line voltage resulting in loss of power and overheating.

The table below shows the correct size to use according to cord length and nameplate ampere rating. If in doubt, use the next heavier gauge. The smaller the gauge number the heavier the cord.

Be sure your extension cord is properly wired and in good condition. Always replace a damaged extension cord or have it repaired by a qualified electrician before using it. Protect your extension cord from sharp objects, excessive heat and damp or wet areas.

Use a separate electrical circuit for your power tools. This circuit must not be less than 14 gauge wire and should be protected with either a 15 AMP time delayed fuse or circuit breaker. Before connecting the power tool to the power source, make sure the switch is in the OFF position and the power source is the same as indicated on the nameplate. Running at lower voltage will damage the motor.

WARNING: Repair or replace damaged or worn extension cords immediately.

Select the appropriate extension cord gauge and length using the chart below.



When operating a power tool outdoors, use an outdoor extension cord marked "W-A" or "W". These cords are rated for outdoor use and reduce the risk of electric shock.











WARNING: Keep the extension cord clear of the working area. Position the cord so it will not get caught on the workpiece, tools or any other obstructions while you are working with the power tool.

MINIMUM GAUGE (AWG) EXTENSION CORDS (120 V use only)					
Ampere rating		Total length in feet			
More than	Not more than	7.5 m (25')	15 m (50')	30 m (100')	45 m (150')
0	6	18	16	16	14
6	10	18	16	14	12
10	12	16	16	14	12
12	16	14	12	Not Applicable	

SYMBOLS

WARNING: Some of the following symbols may appear on the reciprocating saw. Study these symbols and learn their meaning. Proper interpretation of these symbols will allow for more efficient and safer operation of this tool.

V	Volts
A	Amperes
Hz	Hertz
W	Watts
kW	Kilowatts
μF	Microfarads
L	Liters
kg	Kilograms
H	Hours
N/cm ²	Newtons per square centimeter
Pa	Pascals
OPM	Oscillations per minute
Min	Minutes
S	Seconds
 or a.c.	Alternating current
	3-Phase alternating current
	3-Phase alternating current with neutral

	Direct current
n_0	No load speed
	Alternating or direct current
	Class II construction
	Splash-proof construction
	Watertight construction
	Protective grounding at grounding terminal, Class I tools
.../min	Revolutions or reciprocations per minute
∅	Diameter
0	Off position
	Directional arrow
	Warning symbol
	Wear your safety glasses
	Wear your hearing protection



This symbol designates that this tool is listed with Canadian and U.S. requirements by ETL Testing Laboratories, Inc.

Conforms to UL Std. 60745-1 and 60745-2-11.

Certified to CAN/CSA Std.C22.2 No.60745-1, 60745-2-11.

KNOW YOUR RECIPROCATING SAW

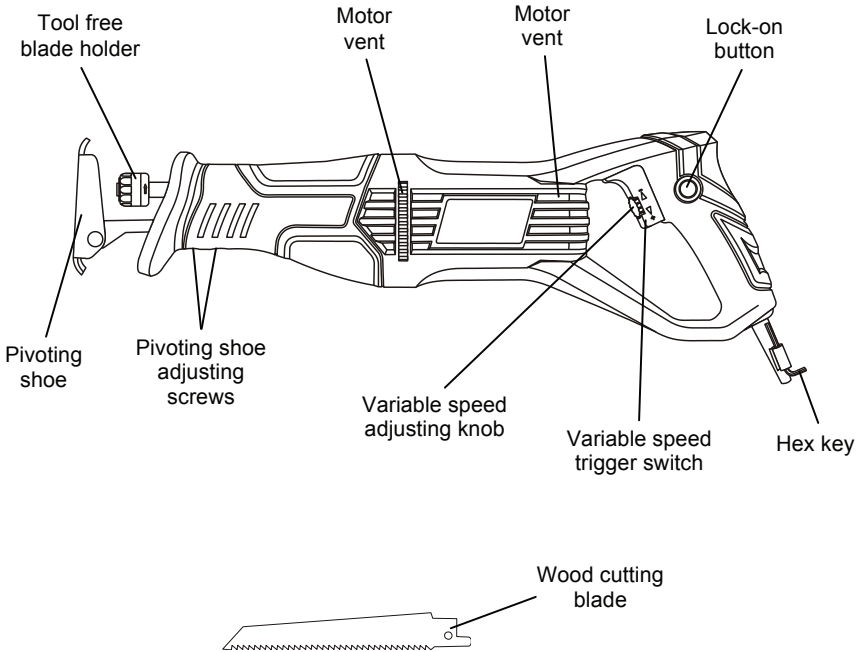

ASSEMBLY AND OPERATING

NOTE: The drawings in the assembly and operating section of this manual may differ slightly from the tool you purchased.

INSTALLING A BLADE

WARNING: Always remove the plug from the power source before installing or removing a blade or adjusting the saw in any way.

1. To install a blade in the saw, rotate the blade locking sleeve (1) counter clockwise (Fig. 1).
2. Insert the appropriate blade (2) into the blade slot (3) as far as it will go.
3. Release the blade locking sleeve.

NOTE: The blade will automatically be locked into the blade holder. Pull outward on the blade to ensure it is properly locked into the blade holder.

REMOVING A BLADE

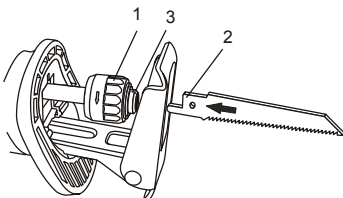

Fig. 1

To remove a blade, simply rotate the blade locking sleeve counter clockwise and remove the blade from the blade holder.

ADJUSTING THE PIVOTING SHOE

The pivoting shoe will pivot to follow the angle of the blade to the workpiece. This

action ensures the flat surface of the shoe is against the workpiece for better cutting action and easier control of the saw.

The shoe can be adjusted in or out, allowing the use of the blade teeth at different points on the blade. This will provide longer blade life as one section of the blade becomes dull.

1. To adjust the pivoting shoe (1), loosen the pivoting shoe hex screws (2) on the lower side of the saw using the 4 mm hex key (3) (Fig. 2).
2. Slide the pivoting shoe in or out until it is in the appropriate position.
3. Lock the pivoting shoe in place by tightening the pivoting shoe hex screws.
4. Pull outward on the pivoting shoe to ensure it is firmly locked in place.

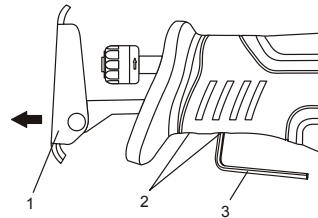

Fig. 2

VARIABLE SPEED TRIGGER SWITCH

The variable speed trigger switch controls both the ON/OFF function and the speed of the tool.

1. To turn the saw ON, squeeze the switch trigger (1) slightly (Fig. 3).

NOTE: The saw will start at its slowest speed.

ASSEMBLY AND OPERATING (continued)

VARIABLE SPEED TRIGGER SWITCH – cont'd

- To increase the speed of the saw, squeeze the switch trigger harder.
NOTE: When the switch trigger is squeezed fully, the saw will run at its maximum speed.
- To turn the saw OFF, release the switch trigger.

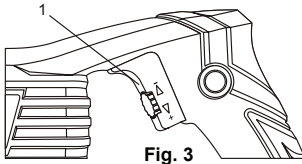

Fig. 3

VARIABLE SPEED ADJUSTING KNOB

The maximum speed of the saw can be controlled by the variable speed adjusting knob (2) (Fig 4).

- To allow the trigger to be fully depressed allowing the saw to operate at its fastest speed, rotate the variable speed control knob downward (3) as far as possible.
- To limit the amount the trigger can be depressed, and to control the maximum speed of the saw, rotate the variable speed adjusting knob upward (4).
NOTE: The further the knob is rotated upward, the slower the maximum speed of the saw will become.

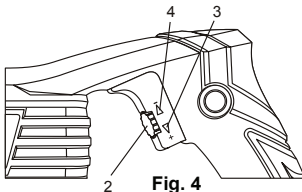

Fig. 4

LOCK-ON BUTTON

Your reciprocating saw is equipped with a lock-on feature, which is convenient when continuous cutting for extended periods of time is required (Fig. 5). To lock the switch ON, depress the trigger switch, push in and hold the lock-on button (5) located at the left side of the handle, then release the trigger. Release the lock-on button and your reciprocating saw will continue running. To turn the reciprocating saw OFF, depress and release the trigger switch to release lock.

NOTE: The lock-on button will only function when the saw is running at full speed.

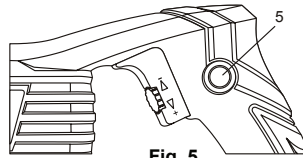

Fig. 5

MATERIALS YOU CAN CUT

This reciprocating saw is a versatile tool that allows you to cut many different types of materials. Some of these materials include:

- Wood products such as lumber, hardwood, plywood, composite board, and paneling
- Drywall
- Fiber board and plastic
- Metals, such as pipe, steel rods, sheet steel, aluminum, brass, and copper.

NOTE: There are many different types of blades available. Generally, there are metal cutting blades (fine teeth) and wood cutting blades (coarse teeth). Use the correct blade for your application. The packaging on the blade will indicate the type of materials each blade is designed to cut.

ASSEMBLY AND OPERATING (continued)

WARNING:

For safety reasons, the operator must read the sections of this Owner's Manual entitled "GENERAL SAFETY WARNINGS", "POWER TOOL SAFETY", "SPECIFIC SAFETY RULES", "EXTENSION CORD SAFETY" and "SYMBOLS" before using this reciprocating saw.

Verify the following every time the reciprocating saw is used:

1. The correct blade for the material being cut is installed in the saw.
2. The blade is firmly clamped in the blade holder.
3. The blade is sharp and in good condition.
4. The workpiece is properly secured.
5. Safety glasses and hearing protection are being worn.

Failure to observe these safety rules will significantly increase the risk of injury.

GENERAL CUTTING

1. Clearly mark the workpiece to locate the position of the cut.
2. Hold smaller workpieces with a vice. Clamp larger workpieces to a workbench or table.

DANGER: Any workpiece that is not adequately clamped in place may come loose and cause serious injury. Never hold the workpiece with your hand.

3. Make sure there are no nails, screws, clamps or foreign materials in the path of the saw blade.
4. Hold the saw away from your body and in front of you (Fig. 6).
5. With both hands firmly gripping the saw, and with the blade NOT in contact

with the surface to be cut, start the saw by squeezing the switch trigger.

6. Once the saw has reached the desired speed, place the adjustable pivoting shoe against the workpiece and gradually bring the moving blade into contact with the workpiece at the appropriate location.

CAUTION: Do not force the saw. Use only enough force to keep the blade cutting. Excessive pressure on the blade will cause it to bend and twist, which may result in breaking the blade.

PLUNGE CUTTING



Fig. 6

1. Clearly mark the workpiece to locate the position of the cut.
2. Clamp the workpiece to a workbench or table (Fig. 7).

NOTE: Make sure the area to be cut is clear under the workpiece so that the blade will not come into contact with anything other than the workpiece.

3. Select a convenient starting point in the area to be cut out. Place the tip of the blade over that point.
4. Rest the lower edge of the adjustable pivoting shoe on the workpiece and hold it firmly in that position, maintaining a shallow cutting angle.
5. Squeeze the switch trigger to start the saw.

ASSEMBLY AND OPERATING (continued)

PLUNGE CUTTING – cont'd

WARNING: Make sure the blade does not touch the workpiece until the saw reaches full speed. Loss of control and possible injury could result.

6. With the saw running at full speed, slowly tilt the saw until the tip of the blade contacts the workpiece and begins to cut. After the blade cuts through the workpiece, tilt the saw upward until the blade is perpendicular to the workpiece.

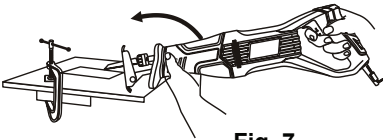

Fig. 7

METAL CUTTING

Metals such as pipe, steel rods, sheet steel, aluminum, brass and copper can be cut with your reciprocating saw (Fig. 8).

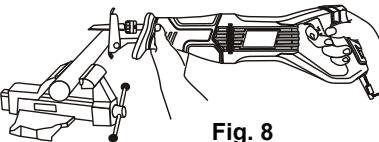

Fig. 8

- Use cutting oil to keep the blade cool, increase cutting action, and prolong the life of the blade.
- Do not twist or bend the saw blade.
- Do not force the saw blade. Let it cut at its own speed.

DANGER:

- a) Always clamp the workpiece in a vice, or to a workbench or table. Do not hold workpiece in your hand.
- b) Never use gasoline as a lubricant or as a cleaning agent. A spark from the motor may cause an explosion. Gasoline will also damage the plastic components of the saw.

- To cut thin sheet material, "sandwich" the material between hardboard or plywood and clamp the layers to limit vibration and material tearing.
- Always use a fine toothed metal cutting blade and run the saw at medium speeds when cutting metal.

MAINTENANCE

GENERAL

WARNING: When servicing, use only identical replacement parts. The use of any other part may create a hazard or cause product damage.

DO NOT use solvents when cleaning plastic parts. Plastics are susceptible to damage from various types of commercial solvents and may be damaged by their use. Use a clean cloth to remove dirt, dust, oil, grease etc.

WARNING: Do not allow brake fluids, gasoline, petroleum-based products, penetrating oils, etc. to come into contact with plastic parts. They contain chemicals that can damage, weaken or destroy plastic.

DO NOT abuse power tools. Abusive practices can damage the tool and the workpiece.

WARNING: DO NOT attempt to modify tools or create accessories. Any such alteration or modification is misuse and could result in a hazardous condition leading to possible serious injury. It will also void the warranty.

It has been found that electric tools are subjected to accelerated wear and possible premature failure when they are used on fiberglass boats and sports cars, wallboard, spackling compounds or plaster. The chips and grindings from these materials are highly abrasive to electric tool parts such as bearings, brushes, commutators, etc. Consequently, it is not recommended that this tool be used for extended work on any fiberglass material, wallboard, spackling compounds or plaster. During any use on

these materials it is extremely important that the tool is cleaned frequently by blowing it out with an air jet.

WARNING: Always wear safety goggles or safety glasses with side shields during all cutting operations. It is critical that you also wear safety goggles or safety glasses with side shields and a dust mask while blowing dust out of the reciprocating saw with an air jet. Failure to take these safety precautions could result in permanent eye or lung damage.

LUBRICATION

All of the bearings in this tool are lubricated with a sufficient amount of high-grade lubricant for the life of the unit under normal conditions. Therefore, no further lubrication is required.

EXPLODED VIEW

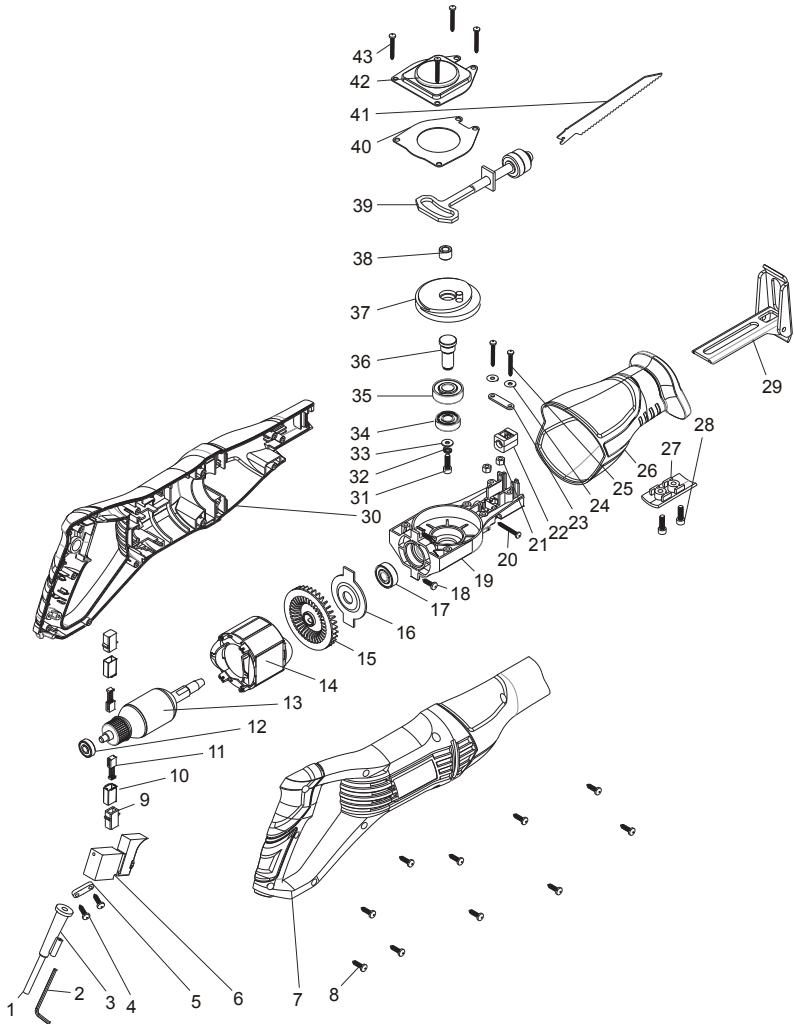

PARTS LIST

WARNING:

When servicing, use only original equipment replacement parts. The use of any other parts may create a safety hazard or cause damage to the reciprocating saw.

Any attempt to repair or replace electrical parts on this reciprocating saw may create a safety hazard unless repairs are performed by a qualified technician. For more information, call the Toll-free Helpline, at 1-866-349-8665.

Always order by PART NUMBER, not by key number.

Key #	Part #	Part Name	Quantity
1	1190030061	Cord set	1
2	6140020012	Hex key	1
3	3140010053	Cord sleeve	1
4	4030010099	Tapping screw ST3.9*14	2
5	2030050002	Strain relief	1
6	1061010013	Switch	1
7	3011110016	Housing	1
8	4030010106	Tapping Screw ST3.9*19	10
9	3150060001	Brush holder sleeve	2
10	2030070004	Brush holder	2
11	1230010122	Carbon brush	2
12	4010010053	Bearing 607 2RS	1
13	1010110015	Rotor	1
14	1020110013	Stator	1
15	3150010029	Fan	1
16	2030030260	Fixed plate	1
17	4010010054	Bearing 6000 2RS	1
18	4030010106	Tapping screw ST3.9*19	2
19	3150070096	Gear box	1
20	4030010116	Tapping screw ST3.9*30	1
21	4060010022	Nut	2
22	2010150055	Reciprocating lever support	1
23	2030160149	Clamping plate	1
24	3150240029	Bearing washer	2
25	4030010192	Tapping screw ST5*25	2
26	3140080045	Rubber boot	1
27	3150160209	Fixed frame	1
28	4020080011	Adjusting screw M5*14	2
29	1150020092	Pivoting shoe assembly	1
30	3011110016	Housing	1
31	4020080011	Adjusting screw M5*14	1
32	4040030003	Spring washer ø5	1
33	4040010009	Bearing washer	1
34	4010010054	Bearing 6000 2RS	1
35	4010010081	Bearing 6201 2RS	1
36	2040040089	Spindle	1
37	2040080028	Big gear	1
38	2040220035	Roller	1
39	1150010044	Plunger assembly	1
40	2030030262	Clamping plate	1
41	6060030005	Blade	1
42	2030030261	Top cover	1
43	4030010249	Tapping screw ST5*14	4

WARRANTY

RADLEY 6 AMP RECIPROCATING SAW WARRANTY

If this Radley Tool fails due to a defect in material or workmanship within one year from the date of purchase, return it to any Home Hardware store with the original bill of sale for exchange. This warranty does not include expendable parts including but not limited to blades, brushes, belts, light bulbs and/or batteries. This warranty covers defects in material or workmanship only. It does not cover normal wear and tear, failure due to abuse/misuse, or defects caused by careless or accidental mishandling. If this Radley product is used for commercial or rental purposes, this warranty does not apply.

Meet Radley

Your demo project didn't just get easier, it's actually about to get a little more, dare we say... fun. Yeah, we went there. But that's only because when you've got a saw that'll cut through nails, wood, steel and pipes it makes a hard day's work not hard at all. Here's one saw that doesn't just cut through drywall, but with the right blade, can cut through literally anything.



Radley[®]

EXCLUSIVE TO HOME HARDWARE

For information on the entire line-up of Radley power tools visit homehardware.ca or your local Home Hardware retail store.

MADE IN CHINA / FABRIQUÉ EN CHINE
HOME HARDWARE STORES LIMITED
ST. JACOBS, ONTARIO N0B 2N0
ORDER ONLINE / COMMANDE EN LIGNE
homehardware.ca

© 06 / 2018 Home Hardware Stores Limited



1270-080