

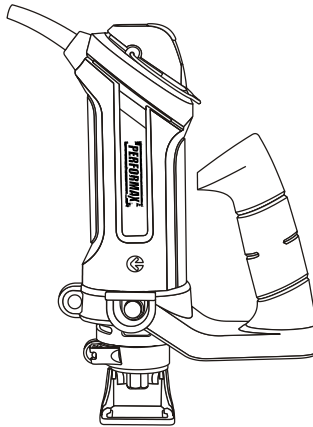

## 5.8 AMP. CUT-OUT SAW

241-0968

### Owner's Manual



#### PRODUCT SPECIFICATIONS

Rating:	120 V, 60 Hz AC
Amperes:	5.8 Amp.
Speed:	10,000 – 30,000 RPM (no load)
Weight:	3 lb 3 oz (1.45 kg)

#### Need Assistance?

Call us on our toll free customer support line:

1-866-349-8665

- Technical questions
- Replacement parts
- Parts missing from package

# TABLE OF CONTENTS

Product specifications .....	1
Table of contents .....	2
General safety warnings .....	3–4
Eye, ear & lung protection .....	3–4
Electrical safety .....	4
Power tool safety .....	5–6
General safety rules .....	5
Work area safety .....	5
Electrical safety .....	5
Personal safety .....	5–6
Power tool use and care.....	6
Service .....	6
Specific safety rules .....	7
Extension cord safety .....	8
Symbols .....	9
Know your cut-out saw .....	10
Available accessories .....	10
Contents .....	11
Assembly and operating .....	12–25
Installing the assist handle .....	12
Installing the freehand cutting guide .....	13
Installing cutting bits .....	13–14
Changing the collet .....	15
ON/OFF switch .....	16
Speed control switch .....	16
Adjusting the freehand cutting guide .....	16–17
Cutting bit applications .....	18
Practice cuts using freehand cutting guide .....	19–20
Cutting tips .....	20–21
Cutting outlet openings in drywall .....	21–23
Installing the circle cutting guide .....	23–24
Circle cutting guide operation .....	24–25
Maintenance .....	26
Exploded view .....	27
Parts list .....	28–29
Warranty .....	30

# GENERAL SAFETY WARNINGS



**WARNING:** Before using this tool or any of its accessories, read this manual and follow all Safety Rules and Operating Instructions. The important precautions, safeguards and instructions appearing in this manual are not meant to cover all possible situations. It must be understood that common sense and caution are factors which cannot be built into the product.

This instruction manual includes the following:

- General Safety Rules
- Specific Safety Rules and Symbols
- Functional Description
- Assembly
- Operation
- Maintenance
- Accessories

## EYE, EAR & LUNG PROTECTION



**ALWAYS WEAR EYE PROTECTION THAT CONFORMS WITH CSA REQUIREMENTS or ANSI SAFETY STANDARD Z87.1**

FLYING DEBRIS can cause permanent eye damage. Prescription eyeglasses ARE NOT a replacement for proper eye protection.



**WARNING:** Non-compliant eyewear can cause serious injury if broken during the operation of a power tool.



**WARNING:** Use hearing protection, particularly during extended periods of operation of the tool, or if the operation is noisy.

**SAVE THESE INSTRUCTIONS FOR REFERENCE**

## GENERAL SAFETY WARNINGS



**WEAR A DUST MASK THAT IS DESIGNED TO BE USED WHEN OPERATING A POWER TOOL IN A DUSTY ENVIRONMENT.**



**WARNING:** Dust that is created by power sanding, sawing, grinding, drilling, and other construction activities may contain chemicals that are known to cause cancer, birth defects, or other genetic abnormalities. These chemicals include:

Lead from lead-based paints

Crystalline silica from bricks, cement, and other masonry products

Arsenic and chromium from chemically treated lumber

The level of risk from exposure to these chemicals varies, according to how often this type of work is performed. In order to reduce exposure to these chemicals, work in a well-ventilated area, and use approved safety equipment, such as a dust mask that is specifically designed to filter out microscopic particles.

## ELECTRICAL SAFETY



**WARNING:** To avoid electrical hazards, fire hazards or damage to the tool, use proper circuit protection.

This tool is wired at the factory for 120V AC operation. It must be connected to a 120V AC, 15 AMP circuit that is protected by a time-delayed fuse or circuit breaker. To avoid shock or fire, replace power cord immediately if it is worn, cut or damaged in any way.

**SAVE THESE INSTRUCTIONS FOR REFERENCE**

# POWER TOOL SAFETY

**⚠ WARNING: Read all safety warnings and instructions.** Failure to follow the warnings and instructions may result in electric shock, fire and/or serious injury.

**Save all warnings and instructions for future reference.**

## Work area safety

**Keep work area clean and well lit.** Cluttered or dark areas invite accidents.

**Do not operate power tools in explosive atmospheres, such as in the presence of flammable liquids, gases or dust.** Power tools create sparks which may ignite the dust or fumes.

**Keep children and bystanders away while operating a power tool.** Distractions can cause you to lose control.

## Electrical safety

**Power tool plugs must match the outlet. Never modify the plug in any way. Do not use any adapter plugs with earthed (grounded) power tools.** Unmodified plugs and matching outlets will reduce risk of electric shock.

**Avoid body contact with earthed or grounded surfaces such as pipes, radiators, ranges and refrigerators.** There is an increased risk of electric shock if your body is earthed or grounded.

**Do not expose power tools to rain or wet conditions.** Water entering a power tool will increase the risk of electric shock.

**Do not abuse the cord. Never use the cord for carrying, pulling or unplugging the power tool. Keep cord away from heat, oil, sharp edges or moving parts.** Damaged or entangled cords increase the risk of electric shock.

**When operating a power tool outdoors, use an extension cord suitable for outdoor use.** Use of a cord suitable for outdoor use reduces the risk of electric shock.

**If operating a power tool in a damp location is unavoidable, use a residual current device (RCD) protected supply.** Use of a ground fault circuit interrupter (GFCI) reduces the risk of electric shock.

## Personal safety

**Stay alert, watch what you are doing and use common sense when operating a power tool. Do not use a power tool while you are tired or under the influence of drugs, alcohol or medication.** A moment of inattention while operating power tools may result in serious personal injury.

**Use personal protective equipment. Always wear eye protection.** Protective equipment such as dust mask, non-skid safety shoes, hard hat, or hearing protection used for appropriate conditions will reduce personal injuries.

**Prevent unintentional starting. Ensure the switch is in the off-position before connecting to power source and/or battery pack, picking up or carrying the tool.** Carrying power tools with your finger on the switch or energizing power tools that have the switch on invites accidents.

**Remove any adjusting key or wrench before turning the power tool on.** A wrench or a key left attached to a rotating part of the power tool may result in personal injury.

**SAVE THESE INSTRUCTIONS FOR REFERENCE**

# POWER TOOL SAFETY

## *PERSONAL SAFETY – cont'd*

**Do not overreach. Keep proper footing and balance at all times.** This enables better control of the power tool in unexpected situations.

**Dress properly. Do not wear loose clothing or jewelry. Keep your hair, clothing and gloves away from moving parts.** Loose clothes, jewelry or long hair can be caught in moving parts.

**If devices are provided for the connection of dust extraction and collection facilities, ensure these are connected and properly used.** Use of dust collection can reduce dust-related hazards.

### **Power tool use and care**

**Do not force the power tool. Use the correct power tool for your application.** The correct power tool will do the job better and safer at the rate for which it was designed.

**Do not use the power tool if the switch does not turn it on and off.** Any power tool that cannot be controlled with the switch is dangerous and must be repaired.

**Disconnect the plug from the power source and/or the battery pack from the power tool before making any adjustments, changing accessories, or storing power tools.** Such preventive safety measures reduce the risk of starting the power tool accidentally.

**Store idle power tools out of the reach of children and do not allow persons unfamiliar with the power tool or these instructions to operate the power tool.** Power tools are dangerous in the hands of untrained users.

**Maintain power tools. Check for misalignment or binding of moving parts, breakage of parts and any other condition that may affect the power tool's operation. If damaged, have the power tool repaired before use.** Many accidents are caused by poorly maintained power tools.

**Keep cutting tools sharp and clean.** Properly maintained cutting tools with sharp cutting edges are less likely to bind and are easier to control.

**Use the power tool, accessories and tool bits etc. in accordance with these instructions, taking into account the working conditions and the work to be performed.** Use of the power tool for operations different from those intended could result in a hazardous situation.

**Hold power tools by insulated gripping surfaces when performing an operation where the cutting tool may contact hidden wiring or its own cord.** Contact with a "live" wire will make exposed metal parts of the tool "live" and shock the operator.

**Use clamps or another practical way to secure and support the workpiece to a stable platform.** Holding the work by hand or against your body leaves it unstable and may lead to loss of control.

### **Service**

**Have your power tool serviced by a qualified repair person using only identical replacement parts.** This will ensure that the safety of the power tool is maintained.

**SAVE THESE INSTRUCTIONS FOR REFERENCE**

## SPECIFIC SAFETY RULES

**⚠ WARNING: Know your cut-out saw. Read the Owner's Manual carefully. Learn the tool's applications and limitations, as well as the specific potential hazards related to this tool.**

Following this rule will reduce the risk of electric shock, fire or serious injury.



Always wear eye protection. Any power tool can throw foreign objects into your eyes and cause permanent eye damage. ALWAYS wear safety goggles (not glasses) that comply with ANSI safety standard Z87.1. Everyday glasses have only impact resistant lenses. They ARE NOT safety glasses.

**⚠ WARNING: Wearing glasses or goggles that do not comply with ANSI Z87.1 could cause serious injury if they break.**

Always wear hearing protection and a dust mask when sanding. Use only in a well-ventilated area. Using personal safety devices and working in a safe environment reduces the risk of injury.

**⚠ WARNING: Always unplug the tool from the power source before changing the bit or an accessory and when cleaning the tool.**

Do not wear gloves, neckties or loose clothing.

Hold tool by the insulated gripping surfaces when performing an operation where the cutting tool may contact hidden wiring or its own cord. Contact with a "live" wire will make exposed metal parts of the tool "live" and shock the operator.

Always make sure the work surface is free from nails and other foreign objects. Cutting into a nail can cause the bit and the tool to jump and damage the bit.

Always use a safe method to secure the workpiece, and use both hands to guide the tool. Never place your hands near or below the cutting surface.

Never lay the workpiece on hard surfaces like concrete, stone, etc. The protruding cutting bit may cause the tool to jump.

After changing the bits, accessories and making adjustments, make sure the collet nut and any other adjustment devices are securely tightened. Loose adjustment devices will be violently thrown.

Never use dull or damaged bits. Sharp bits must be handled with care. Damaged bits can snap during use. Dull bits require more force to push the tool, possibly causing the bit to break.

Never touch the bit during or immediately after use. After use the bit is too hot to be touched by bare hands.

**SAVE THESE INSTRUCTIONS FOR REFERENCE**

# EXTENSION CORD SAFETY

**⚠ WARNING: Keep the extension cord clear of the working area.** Position the cord so it will not get caught on the workpiece, tools or any other obstructions while you are working with the power tool.

Make sure any extension cord used with this tool is in good condition. When using an extension cord, be sure to use one of heavy enough gauge to carry the current the tool will draw. An undersized cord will cause a drop in line voltage resulting in loss of power and overheating.

The table at right shows the correct size to use according to cord length and nameplate ampere rating. If in doubt, use the next heavier gauge. The smaller the gauge number the heavier the cord.

Be sure your extension cord is properly wired and in good condition. Always replace a damaged extension cord or have it repaired by a qualified electrician before using it. Protect your extension cord from sharp objects, excessive heat and damp or wet areas.



Use a separate electrical circuit for your power tools. This circuit must not be less than 14 gauge wire and should be protected with either a 15 AMP time delayed fuse or circuit breaker. Before connecting the power tool to the power source, make sure the switch is in the OFF position and the power source is the same as indicated on the nameplate. Running at lower voltage will damage the motor.









MINIMUM GAUGE (AWG) EXTENSION CORDS (120V use only)					
Amperage rating		Total length			
More than	Not more than	25' (7.5 m)	50' (15 m)	100' (30 m)	150' (45 m)
0	6	18	16	16	14
6	10	18	16	14	12
10	12	16	16	14	12
12	16	14	12	Not Applicable	



# SYMBOLS

**⚠ WARNING:** Some of the following symbols may appear on the cut-out saw. Study these symbols and learn their meaning. Proper interpretation of these symbols will allow for more efficient and safer operation of this tool.

<b>V</b>	Volts
<b>A</b>	Amperes
<b>Hz</b>	Hertz
<b>W</b>	Watts
<b>kW</b>	Kilowatts
<b>μF</b>	Microfarads
<b>L</b>	Liters
<b>kg</b>	Kilograms
<b>H</b>	Hours
<b>N/cm<sup>2</sup></b>	Newtons per square centimeter
<b>Pa</b>	Pascals
<b>OPM</b>	Oscillations per minute
<b>Min</b>	Minutes
<b>S</b>	Seconds
 or a.c.	Alternating current
	Three-phase alternating current
	Three-phase alternating current with neutral

	Direct current
<b>n<sub>0</sub></b>	No load speed
	Alternating or direct current
	Class II construction
	Splash-proof construction
	Watertight construction
	Protective grounding at grounding terminal, Class I tools
<b>.../min</b>	Revolutions or reciprocations per minute
<b>∅</b>	Diameter
<b>0</b>	Off position
	Arrow
	Warning symbol
	Wear your safety glasses

**LISTED**



This symbol designates that this tool is listed with U.S. requirements by ETL Testing Laboratories, Inc. Conforms to UL Std. 745-1, 745-2-17.

# KNOW YOUR CUT-OUT SAW

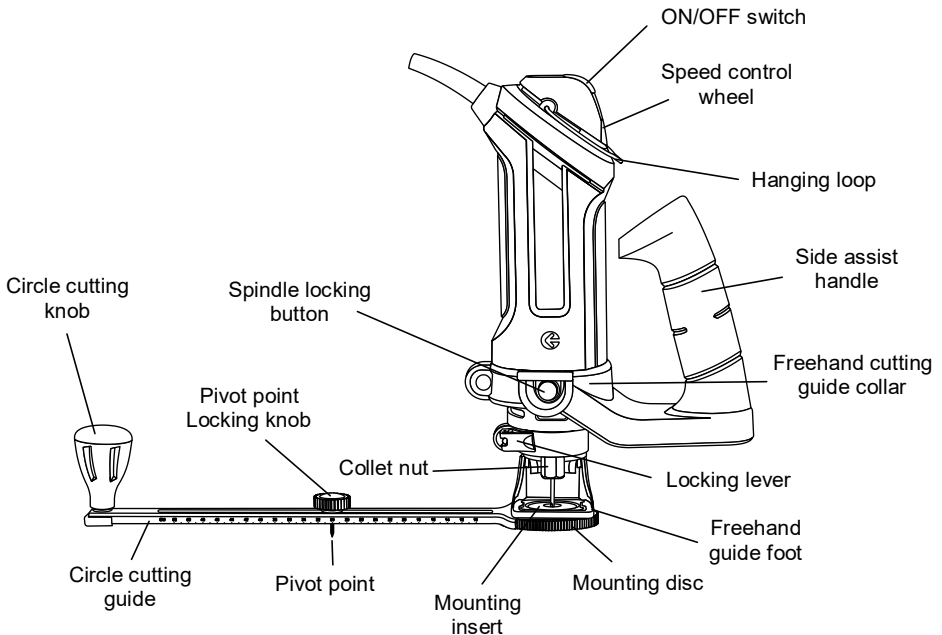

## ACCESSORIES

### AVAILABLE ACCESSORIES

**⚠ WARNING:** Use only accessories that are recommended for this cut-out saw. Follow the instructions that accompany the accessories. The use of improper accessories may result in injury to the operator or damage to the cut-out saw.

**⚠ WARNING:** Router bits are NOT recommended for use with this tool.

Before using any accessory, carefully read the instructions or the owner's manual for the accessory.

- 1/8" Cutting bits
- 1/8" Hobby rotary tool accessories
- Cutters
- Polishers
- Sanders
- Grinders

**⚠ WARNING:** If any part is missing or damaged, do not plug the cut-out saw into the power source until the missing or damaged part is replaced.

# CONTENTS

## CONTENTS

Carefully unpack the cut-out saw.  
Compare the contents against the "CUT-OUT SAW COMPONENTS" chart at right.

**NOTE:** See illustration of the cut-out saw below.

**⚠ WARNING:** To avoid fire or toxic reaction, never use gasoline, naphtha, acetone, lacquer thinner or similar highly volatile solvents to clean the tool.

CUT-OUT SAW COMPONENTS		
KEY	DESCRIPTION	QTY
A	Cut-out saw	1
B	Side assist handle	1
C	Freehand cutting guide	1
D	Circle cutting guide with installation adapter	1
E	1/4" general purpose cutting bit	1
F	1/8" general purpose cutting bit	2
G	1/4" collet	1
H	5/32" collet	1
I	1/8" collet	1
J	Collet wrench	1
	Tote case (Not illustrated)	1
	Owner's Manual	1

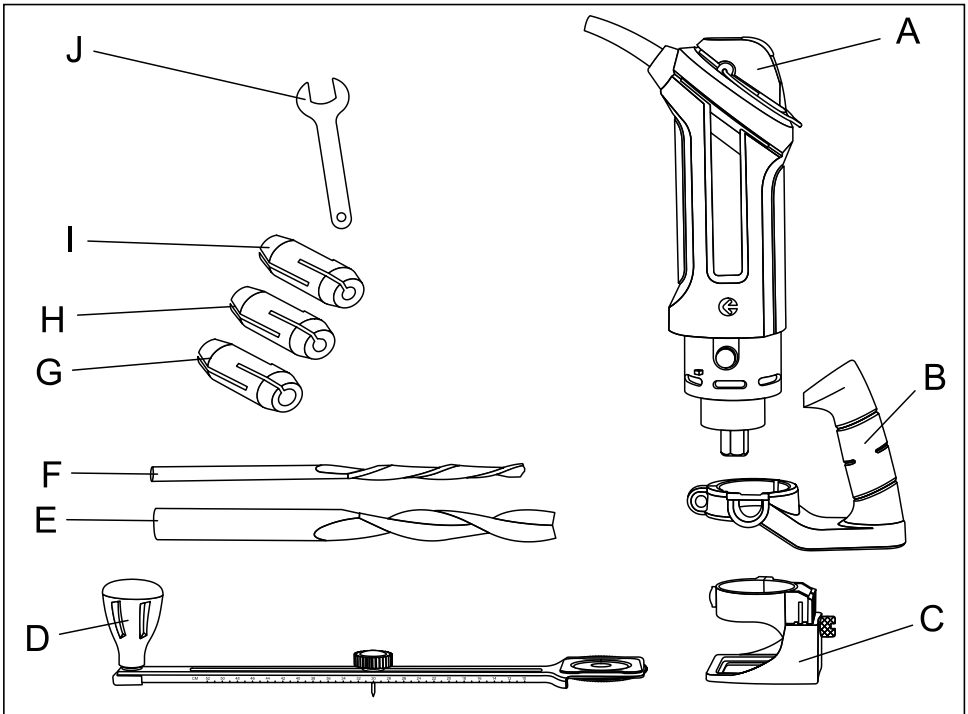

# ASSEMBLY AND OPERATING

**⚠ WARNING:** Remove the plug from the power source before assembly, changing accessories or cutters and making adjustments. This will prevent accidental starting of the tool which could result in serious injury.

## INSTALLING THE ASSIST HANDLE

The removable assist handle is designed for use when precision control over the tool movement is desired. Use the assist handle when operating the tool with either the freehand cutting guide or the circle cutting guide.

1. Open the mounting collar (1) by pulling the quick release lever (2) outward (Fig. 1).
2. Slide the mounting collar onto the bottom of motor housing (2). Make sure the key (3) on the motor housing is aligned with the matching keyway in the mounting collar.
3. When the key and keyway are aligned, slide the mounting collar fully onto the motor housing and then rotate the collar clockwise approximately  $10^\circ$  to lock the key and keyway.

**NOTE:** The mounting bracket must be pushed onto the motor housing as far as it will go.

4. Press the quick release lever inward toward the mounting collar to finish locking the mounting collar onto the motor housing.

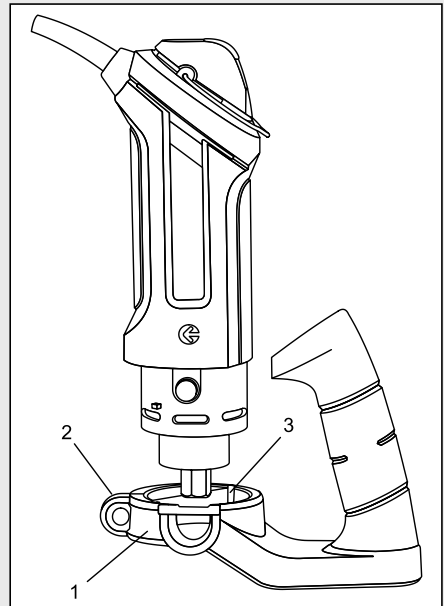

**Fig. 1**

# ASSEMBLY AND OPERATING

## INSTALLING THE FREEHAND CUTTING GUIDE

The freehand cutting guide is designed for basic freehand cutting with the cutting bit. It is ideally suited for cutting electrical outlet holes in drywall.

1. Open the freehand cutting guide mounting collar (1) by pulling the quick release lever (2) outward (Fig. 2).
2. Slide the mounting collar onto the bottom of the motor housing (3).

### NOTES:

- a) The mounting collar must be pushed onto the motor housing as far as it will go.
  - b) Rotate the mounting collar to position it to provide the best visibility to the bit.
3. Lock the freehand cutting guide onto the motor housing by pushing the quick release lever inward toward the mounting collar until it snaps into the locked position.

## INSTALLING CUTTING BITS

**⚠ WARNING: Cutting bit surfaces are extremely sharp. Handle with caution.**

To loosen and tighten the collet use the collet wrench supplied with the tool.

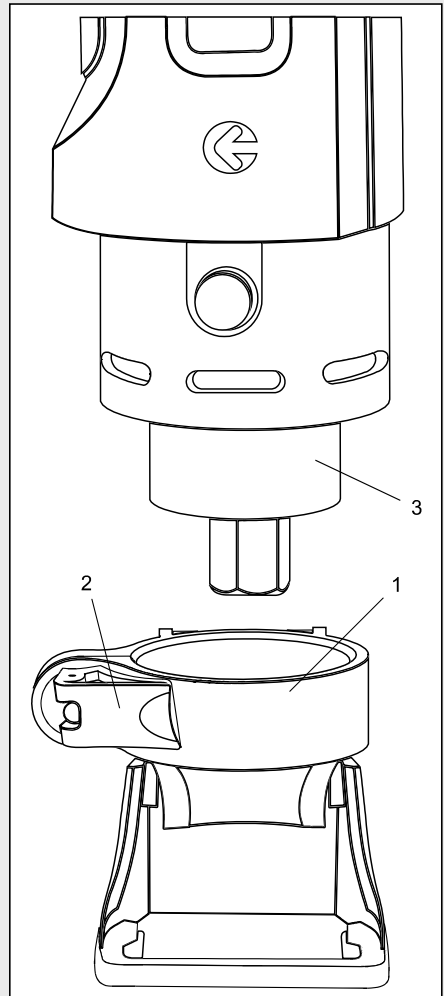

**Fig. 2**

# ASSEMBLY AND OPERATING

## INSTALLING CUTTING BITS – cont'd

1. Depress the shaft locking button (1) and rotate the collet lock nut (2) with the other hand until the locking button drops into place, preventing the shaft from turning (Fig. 3).
2. While continuing to hold the shaft locking button IN, use the collet wrench (3) to turn the collet nut counterclockwise. Loosen the collet nut two or three turns.
3. Remove the bit if one is already installed in the tool.
4. Insert the new cutting bit (4) into the collet.

**NOTE:** If the shank of the bit being installed is a different size than the bit being removed, install the correct collet as outlined in Fig. 4.

**⚠ WARNING:** Insert the bit all the way into the collet and then pull it back between 1/16" and 1/8". This creates an air space between the motor shaft and the bit to help protect the bit from overheating.

**Before tightening the collet on the bit, make sure the flutes (spiral portion) of the bit are completely visible outside the collet. Clamping the collet on the bit flutes will result in broken bits and possible injury.**

5. When the bit is properly placed in the collet, depress the shaft locking button and turn the collet nut clockwise by hand as far as possible.
6. Securely tighten the collet nut using the collet wrench.

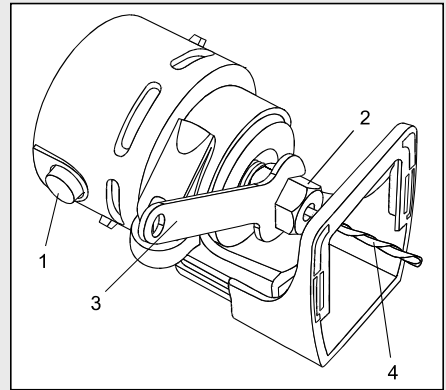

**Fig. 3**

# ASSEMBLY AND OPERATING

## CHANGING THE COLLET

The cutting bits for this tool are locked into place with a collet nut (1) and collet (2) (Fig. 4). 1/8" and 5/32" collets are used for holding 1/8" and 5/32" cutting bits and hobby tool accessory bits. The 1/4" collet is supplied for holding 1/4" drywall bits.

To change from one collet size to the other:

1. Remove bit from the tool.
2. Turn the collet nut counterclockwise until it can be removed from the motor shaft (3) (Fig. 4).
3. Pull the collet out of the motor shaft and insert the new collet.

**NOTE:** Each collet is the same on both ends, so either end can be inserted into the motor shaft.

Reinstall the collet nut and slightly tighten it by hand.

**NOTE:** Tightening the collet nut without a bit in the collet will cause the collet hole to become smaller and make installing bits difficult. When storing the tool with no bit installed, leave the collet nut loose.

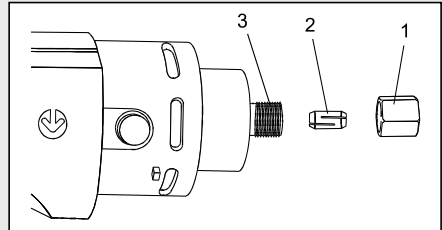

**Fig. 4**

# ASSEMBLY AND OPERATING

## ON/OFF SWITCH

This cut-out saw is equipped with a convenient ON/OFF switch (1) located on the top of the tool handle (Fig. 5). To turn the switch ON, slide the switch outward. To turn the switch OFF, slide the switch inward.

## SPEED CONTROL SWITCH

The cut-out saw is equipped with a variable speed control located below the ON/OFF switch. To run the tool at its slowest speed, rotate the speed control wheel (2) to number "1" (Fig. 6). To increase the tool speed, rotate the speed control wheel in the opposite direction. Maximum speed will be achieved at "6".

## ADJUSTING THE FREEHAND CUTTING GUIDE

1. Adjust the freehand cutting guide depth by loosening the depth gauge locking screw (1) and moving the cutting guide foot (2) up or down as required (Fig. 7).

**NOTE:** Set the foot so the cutting bit protrudes beyond the bottom of the cutting guide 1/8" more than the thickness of the material being cut. For example, if you are cutting 5/8" drywall, the bit should protrude 3/4" beyond the bottom of the cutting guide.

2. Securely tighten depth gauge locking screw.

**NOTE:** Hand tightening is normally adequate. If you use a screwdriver (3), do not overtighten the locking screw.

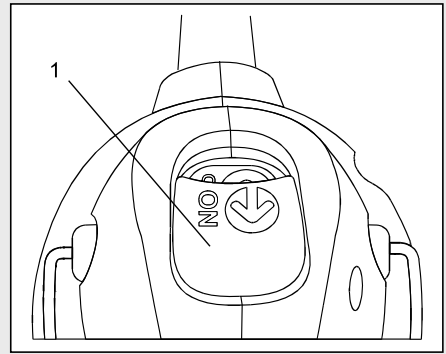

Fig. 5

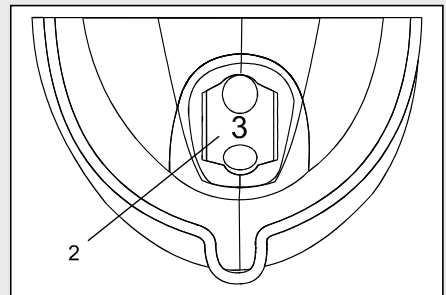

Fig. 6

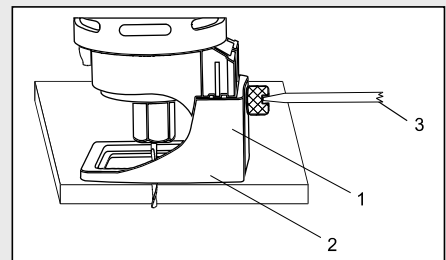

Fig. 7



# ASSEMBLY AND OPERATING

## ADJUSTING THE FREEHAND CUTTING GUIDE – cont'd

Before starting to cut, double check the bit depth. Make sure the cutting guide is at a right angle to the bit and securely tightened. Double check the collet to make sure the bit is securely fastened.

### **WARNING**

For safety reasons, the operator must read the sections of this Owner's Manual entitled "GENERAL SAFETY WARNINGS", "POWER TOOL SAFETY", "SPECIFIC SAFETY RULES", "EXTENSION CORD SAFETY" and "SYMBOLS" before using this cut-out saw.

Verify the following every time the cut-out saw is used:

1. The cord is not damaged.
2. The bit is securely fastened in the collet.
3. The bit is sharp and in good condition.
4. Safety glasses, hearing protection and dust mask are being worn.

Failure to adhere to these safety rules can greatly increase the chances of serious injury.

# ASSEMBLY AND OPERATING

## CUTTING BIT APPLICATIONS

Cutting Bit Type	Material and Thickness	Speed control wheel setting	Recommended Cut Feet per Minute
1/4" (soft wood*, fiberglass and laminate)	Fiberglass and laminate up to 1/4" and soft wood* up to 1"	3-6	1 ft./min
1/4" (windows and doors)	Drywall, gypsum board up to 5/8"	3-6	1.5 ft./min
1/8" (soft wood*, fiberglass and laminate)	Fiberglass and laminate up to 1/8", soft wood* up to 1"	3-6	1 ft./min.
5/32" All purpose (not included)	All materials and thicknesses listed in this chart plus sheet metal up to 1/32" thick	3-6	0.5 to 1.5 ft./min. depending upon the material
1/8" Ceramic tile (not included)	"Porous" ceramic wall tiles up to 3/8"	3-6	0.5 ft./min.

**Soft wood\*** refers to spruce, pine and fir (SPF)

**NOTE:** Refer to the above chart for materials, material thickness, speed of the tool and recommended cut feet per minute to be used with the various cutting bits. The speeds referenced chart are intended as a guide only and must be adjusted according to hardness, density and characteristics of the material being cut. Material thickness must never exceed the length of the cutting flutes. Making practice cuts on a scrap workpiece that is the same material as the good workpiece will assist you in selecting the speeds that will produce the smoothest cut.

# ASSEMBLY AND OPERATING

## PRACTICE CUTS USING THE FREEHAND CUTTING GUIDE

Before attempting to work on an actual project, take the time to make a few practice cuts with your cut-out saw. Use some scraps of material that are the same material as will be used in your actual project.

1. Draw a pattern similar to your first project on a scrap piece of material.
2. Install the assist handle and the freehand cutting guide as shown in Fig. 1 & 2.
3. Install cutting bit in the collet as shown in Fig. 3.
4. Adjust depth of freehand cutting guide as shown in Fig. 7.
5. Set the speed control switch to the appropriate speed.
6. Rest the edge of the cutting guide on the workpiece with the bit at an angle of about 45° (Fig. 8).

**NOTE: DO NOT** let the bit come into contact with the workpiece until the power switch is turned ON and the tool is up to full speed.

**⚠ WARNING:** Before turning the power switch ON, make sure you are holding the tool firmly with both hands. Starting torque will cause the tool to twist.

7. Turn the switch ON.

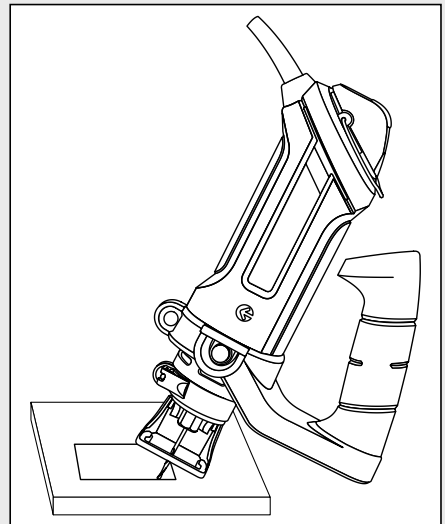

**Fig. 8**

# ASSEMBLY AND OPERATING

## PRACTICE CUTS USING THE FREEHAND CUTTING GUIDE – cont'd

- When the motor is up to full speed, slowly tip the tool to an upright position, letting the bit cut into the workpiece (Fig. 9). Once the tool has reached the upright position and the bit has cut through the workpiece, slowly move the tool in a **clockwise** direction using slow steady pressure to make the cut.

**NOTE:** Except for cutting around outlet boxes in drywall, always cut in a **clockwise** direction.

- When the cut is complete, turn the tool OFF, wait until it comes to a complete stop and remove it from the workpiece.

**⚠ DANGER:** Do not attempt cutting around outlet boxes in drywall until:

- All electricity in the vicinity of electric wires has been disconnected by either turning the breaker OFF or removing the fuses.**
- You have read the instructions on the following page entitled "CUTTING OUTLET OPENINGS IN DRYWALL".**

### CUTTING TIPS

The rotating cutting action of the bit will cause a slight pull to the left when cutting. Natural variations in the structure of wood will cause the bit to "wander". This tendency will be magnified when applying too much pressure to the bit.

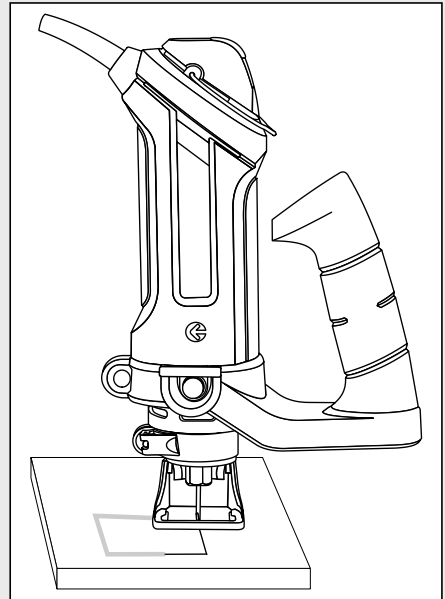

**Fig. 9**

# ASSEMBLY AND OPERATING

## CUTTING TIPS – cont'd

Slower cutting gives you better control. Excessive pressure or fast cutting will increase the bit temperature and shorten the life of the bit.

When cutting a hole in a vertical surface, avoid ending the cut at the bottom of the hole. Always start and end the cut at the “top” so the cut out part will not drop onto the rotating bit. Always turn the tool OFF before removing it from the workpiece.

## CUTTING OUTLET OPENINGS IN DRYWALL

**⚠ DANGER:** Do not attempt to use this tool to make cut outs around any fixture or opening which has live electrical wires or on any wall which may have electrical wiring behind it. If a live wire is contacted, the bit could conduct the electric current to the tool, creating an electrocution hazard for the operator. Turn OFF breakers or remove fuses to disconnect the electric circuit in the area of work. Always hold the tool by its insulated housing when working in areas where there is a possibility of contacting electric wires. Always wear eye, ear and dust protection when operating this tool.

1. Before installing drywall, push the electrical wires to the back of the outlet box as far as possible so they will not be cut by the bit when cutting the opening.
2. Before fastening the drywall sheet over the electrical box, mark the sheet as close as possible to the center of the box opening. Mark should be on the side of the drywall facing you.

# ASSEMBLY AND OPERATING

## CUTTING OUTLET OPENINGS IN DRYWALL – *cont'd*

3. When fastening the drywall in place, do not place nails or screws closer than 12" from the box. This will prevent the drywall from becoming deformed under pressure.
4. Install the assist handle, freehand cutting guide and cutting bit, as outlined in Fig. 1, 2 & 3. Adjust depth of cut so the bit will protrude 1/8" beyond the thickness of the drywall (Fig. 7).
5. Hold the tool firmly with both hands and turn it ON. Plunge the bit through the drywall at the mark indicating the center of the box. See Fig. 10 for cutting pattern.
6. Move the bit **slowly** to the right until you feel and hear the bit contacting the inside of the box.
7. Pull the bit out far enough to slip it over the edge of the box. Once the bit is outside the box, push it back to full depth beside the outside edge of the box.
8. Move the tool upward while applying **slight** pressure toward the center of the box. When you feel the bit reach the top right corner of the box, move the tool to the left while applying slight pressure downward toward the center of the box.
9. Continue moving the tool around the box in a counterclockwise direction while maintaining slight pressure toward the center of the box. When the box cut out is complete, turn the tool OFF and remove it from the cut out.

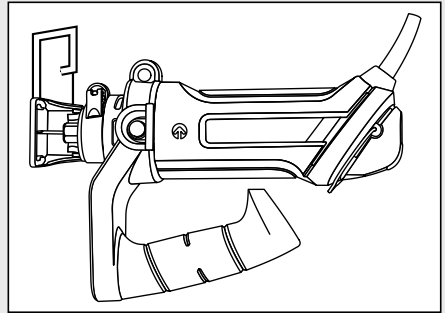

**Fig. 10**

# ASSEMBLY AND OPERATING

## CUTTING OUTLET OPENINGS IN DRYWALL – cont'd

10. The completed electrical box cut out will be accurately and neatly cut (Fig. 11).

**NOTE:** Always move the cutting bit in a **counterclockwise** direction around the outlet box. The natural tendency of the cutting bit to move to the left will make it easier to cut close to the box.

### INSTALLING THE CIRCLE CUTTING GUIDE

The circle cutting guide accessory is ideal for precision cutting of circles. This circle cutting guide must be attached to the freehand cutting guide.

1. Install the assist handle and install and adjust the freehand cutting guide on the tool as illustrated in Fig. 1, 2, 3 & 7.
2. Insert the externally threaded circle cutting guide mounting insert (1) into the bottom of the freehand cutting guide (2) (Fig. 12).

**NOTE:** Make sure the scallops of the insert mate properly with the scallops inside the freehand cutting guide foot.

3. Place the circle cutting guide mounting hole (3) over the externally threaded circle cutting guide mounting insert (4).

**NOTE:** Make sure pointed pivot pin (5) is pointing away from the tool.

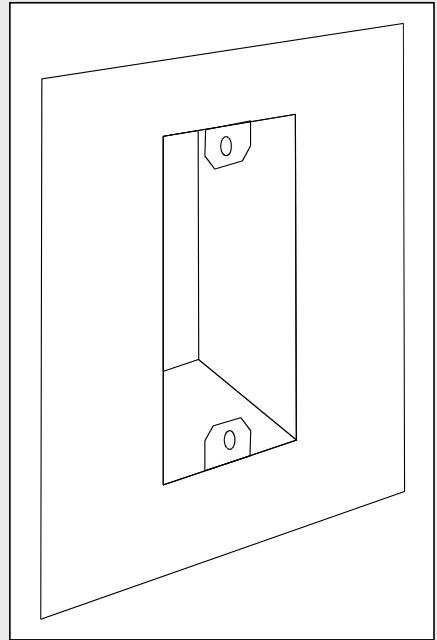

Fig. 11

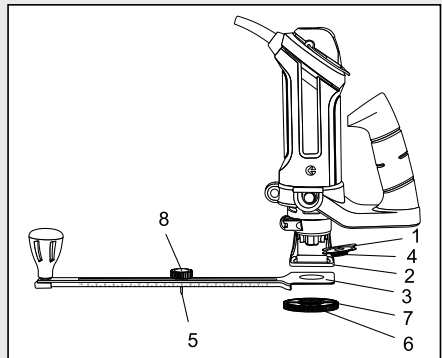

Fig. 12

# ASSEMBLY AND OPERATING

## INSTALLING THE CIRCLE CUTTING GUIDE – cont'd

4. Screw the internally threaded circle cutting guide mounting disc (6) onto the externally threaded circle cutting guide mounting insert and hand tighten.

### NOTES:

- a) Make sure the boss (7) on the cutting guide mounting disc goes through the hole in the circle guide.
- b) Do not overtighten the circle cutting guide mounting plastic parts. Hand tighten only.

5. Adjust the circle cutting guide radius by loosening the pivot point knob (8), sliding it to the correct circle radius and retightening in the desired location.

**NOTE:** Check circle cutting guide radius setting by measuring from the pivot point to the **outside** of the cutting bit.

## CIRCLE CUTTING GUIDE OPERATION

**⚠ WARNING:** Unplug the tool from the power source before changing accessories, changing bits and making adjustments.

**Before turning the tool ON, check to make sure bit and all accessory fasteners are securely tightened.**

1. Mark the center of the circle you wish to cut on the workpiece and drill a 6 mm or 15/64" pilot hole.
2. Adjust cutting bit depth to 1/8" longer than the thickness of the material to be cut (Fig. 7).

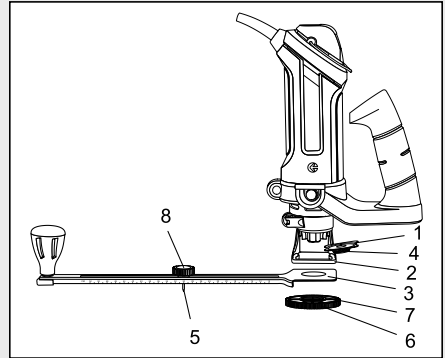

Fig. 12



# ASSEMBLY AND OPERATING

## CIRCLE CUTTING GUIDE OPERATION – cont'd

- Adjust the circle cutting guide radius by loosening the pivot point knob, sliding it to the correct circle radius and retightening in the desired location.

**NOTE:** Check the circle cutting guide radius setting by measuring from the pivot point to the **outside** of the spiral bit.

- Rest the edge of the freehand cutting guide on the workpiece with the bit at an angle of about 45° (Fig. 13). Insert the circle cutting guide pivot point into the pilot hole drilled at the center of the circle.

**NOTE: DO NOT** let the bit touch the workpiece before switch is turned ON and the tool is up to full speed.

- Turn the switch ON.
- When the motor is up to full speed, slowly tip the tool and circle cutting guide assembly to an upright position, letting the bit cut into the workpiece (Fig. 14). Be careful to keep the pivot point located at the center of the circle to be cut. Once the tool has reached the upright position and the bit has cut through the workpiece, slowly move the tool in a **clockwise** direction using slow steady pressure to make the cut. Continue to cut the circle, keeping the tool upright and rotating around the circle cutting guide pivot point.
- When cut is complete, turn the tool OFF, wait until it comes to a complete stop and remove it from the workpiece.

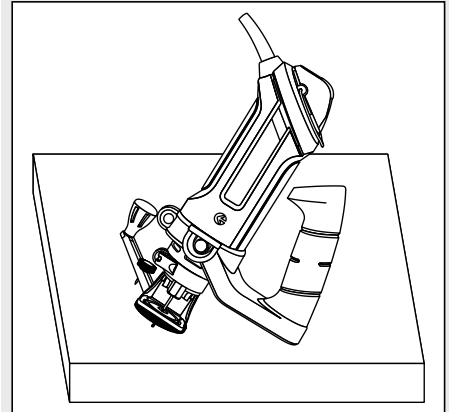

Fig. 13

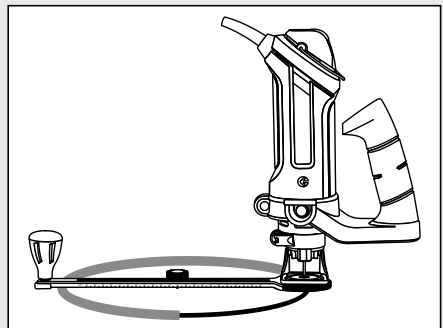

Fig. 14

# MAINTENANCE

## GENERAL

**⚠ WARNING:** When servicing, use only identical replacement parts. The use of any other part may create a hazard or cause product damage.

DO NOT use solvents when cleaning plastic parts. Plastics are susceptible to damage from various types of commercial solvents and may be damaged by their use. Use a clean cloth to remove dirt, dust, oil, grease etc.

**⚠ WARNING:** Do not allow brake fluids, gasoline, petroleum-based products, penetrating oils, etc. to come into contact with plastic parts. They contain chemicals that can damage, weaken or destroy plastic.

DO NOT abuse power tools. Abusive practices can damage the tool and the workpiece.

**⚠ WARNING:** DO NOT attempt to modify tools or create accessories. Any such alteration or modification is misuse and could result in a hazardous condition leading to possible serious injury. It will also void the warranty.

Remove accumulated dust and debris regularly using a soft DRY brush.

It has been found that electric tools are subjected to accelerated wear and possible premature failure when they are used on fiberglass boats and sports cars, wallboard, spackling compounds or plaster. The chips and grindings from these materials are highly abrasive to electric tool parts such as bearings, brushes, commutators, etc. Consequently, it is not recommended that this tool be used for extended work on any fiberglass material, wallboard, spackling compounds or plaster. During any use on these materials it is extremely important that the tool is cleaned frequently by blowing it out with an air jet.

**⚠ WARNING:** Always wear safety goggles or safety glasses with side shields during all sanding operations. It is critical that you also wear safety goggles or safety glasses with side shields and a dust mask while blowing dust out of the cut-out saw with an air jet. Failure to take these safety precautions could result in permanent eye or lung damage.

## LUBRICATION

All of the bearings in this tool are lubricated with a sufficient amount of high-grade lubricant for the life of the unit under normal conditions. Therefore, no further lubrication is required.

# EXPLODED VIEW

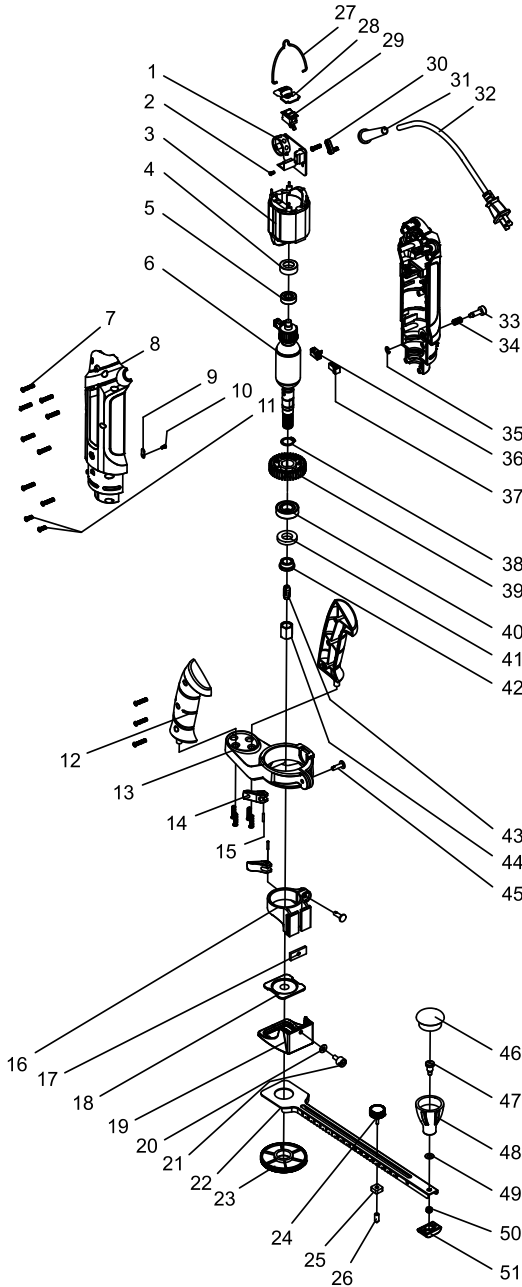

# PARTS LIST

**⚠ WARNING:** When servicing, use only original equipment replacement parts. The use of any other parts may create a safety hazard or cause damage to the cut-out saw.

Any attempt to repair or replace electrical parts on this cut-out saw may create a safety hazard unless repairs are performed by a qualified technician. For more information, call the Toll-free Helpline, at 1-866-349-8665 Monday – Friday from 9am to 5pm Eastern Standard Time.

**Always order by PART NUMBER, not by key number.**

Key #	Part #	Part Name	Quantity
1	1130010008	V.S. PCB	1
2	4030010023	Tapping screw	1
3	1020270002	Stator	1
4	3140040006	Bearing sleeve	1
5	4010010060	Ball bearing 608-2Z	1
6	1010270002	Rotor	1
7	4030010106	Tapping screw	25
8	3011270003	Housing	1
9	2030020089	Pad	1
10	4030010020	Tapping screw	1
11	4030010099	Tapping screw	4
12	3120070026	Handle I	1
13	3150160058	Handle support	1
14	3120100002	Locking lever	3
15	2040160025	Pin	3
16	3150160019	Base support	1
17	2040150008	Locking nut	1
18	3150160009	Permanent seat	1
19	3150120011	Base plate	1
20	4040010012	Rivet	1

# PARTS LIST

Key #	Part #	Part Name	Quantity
21	2040140007	Bakelite ball	1
22	2030030014	Ruler	1
23	3150100001	Round nut	1
24	1160030002	Positioning knob	1
25	4060020001	Square nut	1
26	3140080001	Protection sleeve	1
27	2050080075	Flying rings	1
28	3120110009	Switch button	1
29	1061150001	Switch	1
30	3150020005	cord clamp	1
31	3140010014	cord guard	1
32	1190030006	AC cord & plug	1
33	3120020015	Lock button	1
34	2050060023	Spring	1
35	410050002	Retaining ring	1
36	2030070016	Brush holder	2
37	1230010016	Carbon brush assembly	2
38	4100020013	Shoulder ring	1
39	3150010013	Fan	1
40	4010010058	Ball bearing 6002-2RS	1
41	3190010005	Felt seal	1
42	2040150006	Locking nut	1
43	1140060002	Collet 1/4"	1
44	2040190003	Collet nut	1
45	2030030024	Pin	3
46	3160020001	Grip cover	1
47	2040140004	Set screw	1
48	3120070003	Grip	1
49	4040010021	Rivet	1
50	4060090001	Hexagon nut	1
51	3150130013	Scale board	1

## **PERFORMAX® 5.8 AMP. CUT-OUT SAW WARRANTY**

### **30-DAY MONEY BACK GUARANTEE:**

This PERFORMAX® brand power tool carries our 30-Day Money Back Guarantee. If you are not completely satisfied with your PERFORMAX® brand power tool for any reason within thirty (30) days from the date of purchase, return the tool with your original receipt to any MENARDS™ retail store, and we will provide you a refund – no questions asked.

### **2-YEAR LIMITED WARRANTY:**

This PERFORMAX® brand power tool carries a 2-Year Limited Warranty to the original purchaser. If, during normal use, this PERFORMAX® power tool breaks or fails due to a defect in material or workmanship within two (2) years from the date of original purchase, simply bring this tool with the original sales receipt back to your nearest MENARDS™ retail store. At its discretion, PERFORMAX® agrees to have the tool or any defective part(s) repaired or replaced with the same or similar PERFORMAX® product or part free of charge, within the stated warranty period, when returned by the original purchaser with original sales receipt. Notwithstanding the foregoing, this limited warranty does not cover any damage that has resulted from abuse or misuse of the Merchandise. This warranty: (1) excludes expendable parts including but not limited to blades, brushes, belts, bits, light bulbs, and/or batteries; (2) shall be void if this tool is used for commercial and/or rental purposes; and (3) does not cover any losses, injuries to persons/property or costs. This warranty does give you specific legal rights and you may have other rights, which vary from state to state. Be careful, tools are dangerous if improperly used or maintained. Seller's employees are not qualified to advise you on the use of this Merchandise. Any oral representation(s) made will not be binding on seller or its employees. The rights under this limited warranty are to the original purchaser of the Merchandise and may not be transferred to any subsequent owner. This limited warranty is in lieu of all warranties, expressed or implied including warranties or merchantability and fitness for a particular purpose. Seller shall not be liable for any special, incidental, or consequential damages. The sole exclusive remedy against the seller will be for the replacement of any defects as provided herein, as long as the seller is willing or able to replace this product or is willing to refund the purchase price as provided above. For insurance purposes, seller is not allowed to demonstrate any of these power tools for you.

For questions / comments, technical assistance or repair parts –  
Please Call Toll Free at: 1-866-349-8665 (M-F 8am – 6pm)

**SAVE YOUR RECEIPTS. THIS WARRANTY IS VOID WITHOUT THEM.**

Distributed by: Menard, Inc., Eau Claire, WI 54703