

# BENCHMARK<sup>TM</sup> MC

## BISCUIT JOINER



120V 60Hz 5.9Amp  
5 year limited warranty on tool



  
Intertek  
4006849  
M1K-ZK5-100

**READ ALL INSTRUCTIONS BEFORE FIRST USE.  
KEEP THIS MANUAL FOR FUTURE REFERENCE.  
KEEP AWAY FROM CHILDREN.**



**WEAR CSA APPROVED  
EYE PROTECTION**



**WEAR EAR  
PROTECTION**



**WEAR A  
FACE MASK**

## PRODUCT SPECIFICATIONS

<b>5.9 AMP BISCUIT JOINER</b>	
Voltage	120V~ 60Hz
Rated Power	5.9A
Blade Diameter	4" (100mm)
No-load speed	11600 /min
Arbor	7/8" (22mm)
Blade diameter	4" approx. (100mm)
Fence adjustment range	0-90
Fence height adjustment range	0 - 1-9/16" (0 – 40mm)
Cutting depth:	0 - 3/4" (0 - 19mm)
Weight	5.8 lbs (2.65kg)

### NEED ASSISTANCE?

Call us on our toll- free customer support line:

1-866-349-8665 (Monday through Friday 9am – 5pm Eastern Standard Time)

- Technical questions
- Replacement parts
- Parts missing from package

**TABLE OF CONTENTS**

Product Specifications ..... 1

Table of Contents ..... 2

General Safety Warnings ..... 3

General Power Tool Safety Warnings..... 5

Work Area Safety ..... 5

Electrical Safety..... 5

Personal Safety ..... 5

Specific Safety Rules for Biscuit Joiners ..... 7

Safety Symbols ..... 9

Know Your Biscuit Joiner ..... 10

Assembly ..... 11

Operation ..... 13

Maintenance ..... 18

Troubleshooting..... 20

Exploded View ..... 21

Parts List ..... 22

Warranty ..... 24











## GENERAL SAFETY WARNINGS



### IMPORTANT SAFETY INSTRUCTIONS

Read and understand all safety and operational instructions. Failure to follow the safety rules listed below and other basic safety precautions may result in serious personal injury. Keep this manual, sales receipts and applicable warranty forms for future reference.

### SAFETY SYMBOLS

The purpose of safety symbols is to alert you of the potential safety RISKS. Recognize and understand them. Follow the instructions provided.

SYMBOL	MEANING
	Failure to obey a <b>DANGER</b> safety alert <b>WILL</b> result in serious personal injury or death to you or to others. Always obey all messages following this symbol to reduce the risk of serious personal injury or death.
	Failure to obey a <b>WARNING</b> safety alert <b>MAY</b> result in serious personal injury or death to you or to others. Always obey all messages following this symbol to reduce the risk of potential serious personal injury or death.
	Failure to obey a <b>CAUTION</b> safety alert <b>MAY</b> result in personal injury or property damage to you or to others. Always obey all messages following this symbol to reduce the risk of personal injury or property damage.
	Failure to obey a <b>NOTICE</b> or a <b>CAUTION</b> (without a safety alert) <b>MAY</b> result in property damage to you or to others. Always obey all messages following this symbol to reduce the risk of property damage.
  	<b>ALWAYS WEAR EYE PROTECTION THAT CONFORMS WITH CSA Z94.3 or ANSI SAFETY STANDARD Z87.1</b> FLYING DEBRIS can cause permanent eye damage. Prescription eyeglasses ARE NOT a replacement for proper eye protection. The usage of a safety standard compliant face shield placed over proper safety glasses or goggles can reduce the risk of facial injury. <b>Non-compliant eyewear can cause serious injury if broken during the operation of a power tool.</b>
 	<b>Use hearing protection, particularly during extended periods of operation of the tool, or if the operation is noisy.</b>
 	<b>WEAR A DUST MASK THAT IS DESIGNED TO BE USED WHEN OPERATING A POWER TOOL IN A DUSTY ENVIRONMENT.</b> Refer to Page 7 of the manual for California Prop 65 warnings relating to hazardous dust particles/

SYMBOL	MEANING
<p><b>⚠ WARNING</b></p> 	<p><b>Always wear non-slip gloves that fit properly to protect your hands and to help you grip the tool.</b></p> <p><b>Always wear sturdy clothing with long sleeves and long pants. Never operate the tool while wearing shorts, short sleeve shirt or while shirtless.</b></p> <p><b>Always wear non-slip safety boots to prevent foot injuries and slipping that could cause loss of control of the tool.</b></p>
<p><b>⚠ WARNING</b></p> 	<p><b>To avoid electrical hazards, fire hazards or damage to the tool, use proper circuit protection.</b></p> <p>This tool is wired at the factory for 120 V AC operations. It must be connected to a 120 V AC, 15 A circuit that is protected by a time-delayed fuse or circuit breaker. To avoid shock or fire, replace power cord immediately if it is worn, cut or damaged in any way.</p>
<p><b>⚠ WARNING</b></p> 	<p><b>WARNING:</b> Ventilation openings in batteries and chargers must always be open to allow cooling air to circulate freely. Air vents that are blocked, restricted or covered may result in the battery or charger overheating. Overheating may lead to damage to the tool or cause a fire, resulting in possible serious injury.</p>

## GENERAL POWER TOOL SAFETY WARNINGS

Read all safety warnings and all instructions. Failure to follow the warnings and instructions may result in electric shock, fire and/or serious injury.

Save all warnings and instructions for future reference. The term “power tool” in the warnings refers to your mains operated (corded) power tool or battery-operated (cordless) power tool.

### WORK AREA SAFETY

- Keep work area clean and well lit. Cluttered or dark areas invite accidents.
- Do not operate power tools in explosive atmospheres, such as in the presence of flammable liquids, gases or dust. Power tools create sparks which may ignite the dust or fumes.
- Keep children and bystanders away while operating a power tool. Distractions can cause you to lose control.

### ELECTRICAL SAFETY

- Power tool plugs must match the outlet. Never modify the plug in any way. Do not use any adapter plugs with earthed (grounded) power tools. Unmodified plugs and matching outlets will reduce risk of electric shock.
- Avoid body contact with earthed or grounded surfaces, such as pipes, radiators, ranges and refrigerator. There is an increased risk of electric shock if your body is earthed or grounded.
- Do not expose power tools to rain or wet conditions. Water entering a power tool will increase the risk of electric shock.
- Do not abuse the cord. Never use the cord for carrying, pulling or unplugging the power tool. Keep cord away from heat, oil, sharp edges and moving parts. Damaged or entangled cords increase the risk of electric shock.
- When operating a power tool outdoors, use an extension cord suitable for outdoor use. Use of a cord suitable for outdoor use reduces the risk of electric shock.
- If operating a power tool in a damp location is unavoidable, use a residual current device (RCD) protected supply. Use of an RCD reduces the risk of electric shock.

### PERSONAL SAFETY

- Stay alert, watch what you are doing and use common sense when operating a power tool. Do not use a power tool while you are tired or under the influence of drugs, alcohol or medication. A moment of inattention while operating power tools may result in serious personal injury.
- Use personal protective equipment. Always wear eye protection. Protective equipment such as dust mask, non-skid safety shoes, hard hat, or hearing protection used for appropriate conditions will reduce personal injuries.
- Prevent unintentional starting. Ensure the switch is in the off-position before connecting to power source and/or battery pack, picking up or carrying the tool. Carrying power tools with your finger on the switch or energising power tools that have the switch on invites accidents.

- Remove any adjusting key or wrench before turning the power tool on. A wrench or a key left attached to a rotating part of the power tool may result in personal injury.
- Do not overreach. Keep proper footing and balance at all times. This enables better control of the power tool in unexpected situations.
- Dress properly. Do not wear loose clothing or jewellery. Keep your hair, clothing and gloves away from moving parts. Loose clothes, jewellery or long hair can be caught in moving parts.
- If devices are provided for the connection of dust extraction and collection facilities, ensure these are connected and properly used. Use of dust collection can reduce dust-related hazards.

### **POWER TOOL USE AND CARE**

- Do not force the power tool. Use the correct power tool for your application. The correct power tool will do the job better and safer at the rate for which it was designed.
- Do not use the power tool if the switch does not turn it on and off. Any power tool that cannot be controlled with the switch is dangerous and must be repaired.
- Disconnect the plug from the power source and/or the battery pack from the power tool before making any adjustments, changing accessories, or storing power tools. Such preventive safety measures reduce the risk of starting the power tool accidentally.
- Store idle power tools out of the reach of children and do not allow persons unfamiliar with the power tool or these instructions to operate the power tool. Power tools are dangerous in the hands of untrained users.
- Maintain power tools. Check for misalignment or binding of moving parts, breakage of parts and any other condition that may affect the power tool's operation. If damaged, have the power tool repaired before use. Many accidents are caused by poorly maintained power tools.
- Keep cutting tools sharp and clean. Properly maintained cutting tools with sharp cutting edges are less likely to bind and are easier to control.
- Use the power tool, accessories and tool bits etc. in accordance with these instructions, taking into account the working conditions and the work to be performed. Use of the power tool for operations different from those intended could result in a hazardous situation.

### **SERVICE**

- Have your power tool serviced by a qualified repair person using only identical replacement parts. This will ensure that the safety of the power tool is maintained.

## SPECIFIC SAFETY RULES FOR BISCUIT JOINERS

### **WARNING**

Serious cuts, amputation, or death can occur from contact with rotating saw blade during operation. Workpieces, broken blades, or flying particles thrown by blade can blind or strike operators or bystanders with great force. To reduce the risk of these hazards, operator and bystanders **MUST** completely heed the hazards and warnings below.

**PROPERLY MAINTAIN BLADE.** Always ensure Biscuit Joiner blade is sharp, undamaged, and tightly attached before each use.

**AVOID TOUCHING BLADE.** Never place hands or fingers between work-piece and blade, and do not perform a cut while supporting workpiece with one hand or balancing it on a leg or any other body part.

**PROPERLY SUPPORT WORKPIECE.** Properly support all workpieces to reduce risk of workpiece and tool slipping during cutting operation. Place workpiece on supports or workbench and clamp in place.

**USE BISCUIT JOINER FOR INTENDED PURPOSE.** Only use Biscuit Joiner on wood and wood-based products. Do not attempt to use this tool for any operation other than biscuit joining.

**USE RECOMMENDED BLADES.** Only use blades rated for speeds greater than 11,000 RPM. Blades not rated for this speed may fly apart. Only use blades that meet the specifications listed in the manual. Do not use blades with different diameters or arbor hole shapes/sizes. They will rotate irregularly, causing ejection of blade fragments and tool damage.

**PROPERLY INSTALL COMPONENTS.** Ensure sliding base, faceplate, and fence are in place and operating correctly before each cut.

**STARTING AND STOPPING CUTS.** Allow blade to reach full speed before cutting. Always allow blade to come to a complete stop before setting tool down.

**MAINTAIN CONTROL OF TOOL.** Hold tool with both hands and do not allow the Biscuit Joiner base to shift while performing plunge cuts. Always use the guard. The guard protects the operator from broken blade fragments and unintentional contact with the blade.

- Hold the power tool by its insulated gripping surfaces, because the blade may contact its own cord. Cutting a “live” wire may make exposed metal parts of the power tool “live” and could give the operator an electric shock.
- Always use correctly sized blades with the fitting mounting bore. Blades that do not fit to the mounting components of the biscuit joiner rotate irregularly and lead to loss of control.
- Do not use blunt or damaged blade. Blunt or damaged blades cause increased friction, can become jammed and lead to imbalance.
- Before putting into operation, check that the guard is retracting freely.
- Always wear hearing protection when operating the biscuit joiner.



** CAUTION:**

Like all machinery there is potential danger when operating this tool. Accidents are frequently caused by lack of familiarity or failure to pay attention. Use this tool with respect and caution to decrease the risk of operator injury. If normal safety precautions are overlooked or ignored, serious personal injury may occur.











**SAVE THIS USER MANUAL**** WARNING**

MISUSE or failure to follow the safety rules stated in this instruction manual may cause serious personal injury.

<b>MINIMUM GAUGE (AWG) EXTENSION CORD (120 V use only)</b>					
<b>Amperage rate</b>		<b>Total length</b>			
More than	Not more than	25' (7.5 m)	50' (15 m)	100' (30 m)	150' (45m)
0	6	18	16	16	14
6	10	18	16	14	12
10	12	16	16	14	12
12	16	14	12	Not Applicable	

## SAFETY SYMBOLS

The rating plate on your tool may show symbols. These represent important information about the product or instructions on its use.

	<b>WARNING:</b> Please read all of the safety and operating instructions carefully before using this tool. Please pay particular attention to all sections of this User Guide that carry warning symbols and notices. Some of the following symbols may be used on this tool.
	Observe caution and safety notes.
	To reduce the risk of injury, user must read and understand User Guide before using this tool.
	Wear ear protection.
	Wear protective helmet and eye protection.
	Switch off and remove plug from power source before cleaning or maintenance.
	Do not use in the rain or leave outdoors while it is raining.
	Keep bystanders away.
	Don't touch the inlet and outlet when the vacuum cover is opened or the tube is removed.
	Double insulation.
	Remove plug from the power source immediately if the power cord is damaged or cut.



This symbol designates that this tool is listed with Canadian and U.S. requirements by ETL Testing Laboratories, Inc.  
 Conforms to UL Std. 62841-1:2015 and 62841-2-14:2016  
 Certified to the CAN/CSA Std. C22.2 No. 60745-1 and 60745-2-19

## KNOW YOUR BISCUIT JOINER

### **ATTENTION**

Always be sure that the tool is switched off and unplugged before making any adjustments to the tool.

### **FUNCTIONS**

- |                        |                       |
|------------------------|-----------------------|
| 1. Spindle Lock Button | 2. Fence Lock Knob    |
| 3. Fence               | 4. Fence Height Scale |
| 5. Angle               | 6. ON/OFF Switch      |
| 7. Fence Angle Lock    | 8. Faceplate          |
| 9. Depth Indicator     | 10. Depth Stop        |
| 11. Sliding Base       | 12. Dust Port         |
| 13. Dust Bag           | 14. Blade Access Knob |
| 15. Auxiliary Handle   |                       |

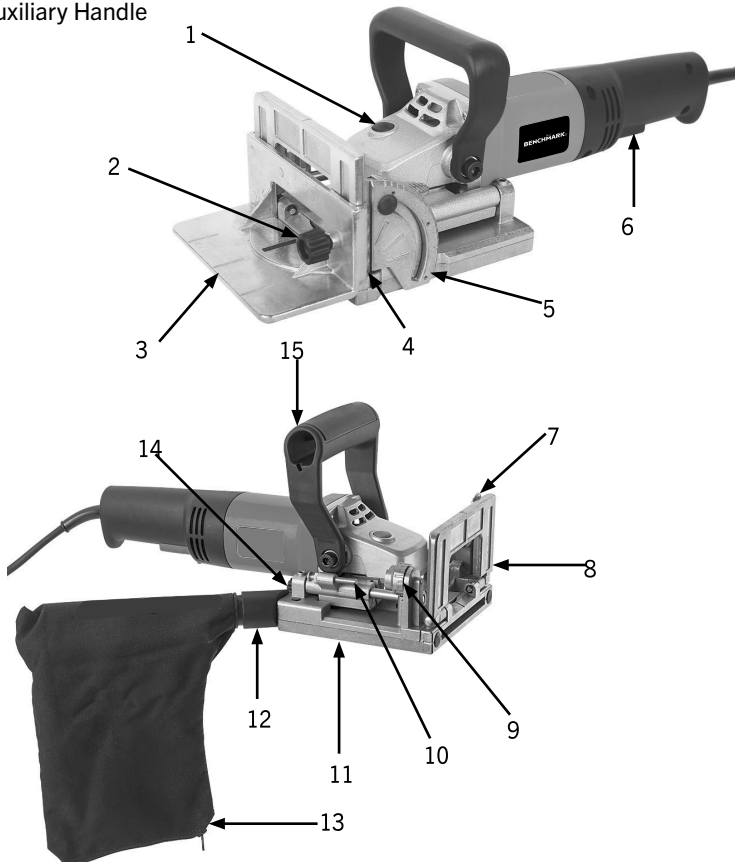

## ASSEMBLY

**⚠ATTENTION:** Read the entire important safety information section at the beginning of this manual including all text under subheadings therein before set up or use of this product.

### CONTROLS & COMPONENTS

**⚠ATTENTION:**

Refer to Figures 1 & 2 and the following descriptions to become familiar with the basic controls of this tool.

- A. Spindle Lock Button: When pressed, locks spindle for removing/replacing blade.
- B. Fence Lock Knob: Locks fence at desired height of cut.
- C. Fence: Orients tool to workpiece at specified angle.
- D. Fence Height Scale: Indicates distance between center of blade and bottom of fence.
- E. Angle Scale: Indicates angle of cut.
- F. ON/OFF Switch: Starts and stops motor. Tool will remain running while switch is held until released.

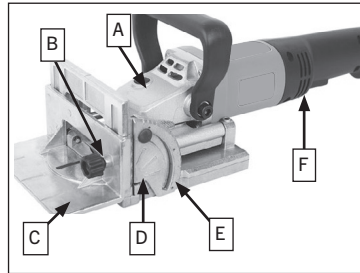

Fig.1: Fence adjustment and power controls

- G. Dust Port: Connects dust extraction system to blade housing and prevents dust build up during cutting operations.
- H. Sliding Base: Houses blade. Spring action retracts blade after cut.
- I. Depth Stop: Contacts turret stop during operation, limiting depth of cut.

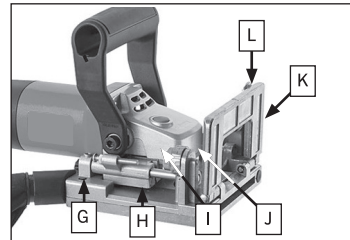

Fig.2: Depth adjustment, angle lock, and dust port.

- J. Depth Indicator: Six-position turret for selecting biscuit cut depth (0, 10, 20, S, D, and MAX).
- K. Faceplate: Contacts edge of workpiece at desired location of biscuit groove.
- L. Angle Lock: Locks faceplate to desired angle of cut.

**⚠WARNING**

Always disconnect this tool from the power supply before attaching or removing accessories, or making any adjustments.

### TO ASSEMBLE TOOL:

1. Loosen fence lock knob, and slide fence onto faceplate (see Figure 6).
2. Tighten fence lock knob (see Figure 6) The machine is equipped with a 1" dust port that can attach to a dust collection system (not included) or the included dust bag.

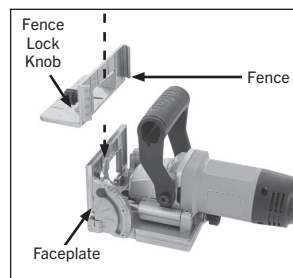

Fig.6: Fence attached to faceplate.

**TO INSTALL DUST BAG:**

1. Push plastic end of dust bag into dust port, as shown in Figure 7.
2. Verify dust bag is closed before operating tool.  
**Note:** If using the dust bag, remove and clean out on a regular basis. Ideally, empty the dust bag when it is half full.

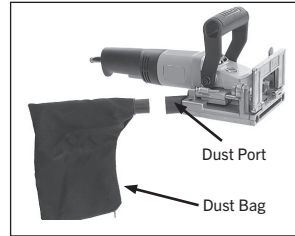

Fig. 7: Installing dust bag into dust port

**TEST RUN**

Once assembly is complete, test run the tool to ensure it is properly connected to power and safety components are working properly. If you find an unusual problem during the test run, immediately stop the tool, disconnect it from power, and fix the problem **BEFORE** operating the tool again.

The Troubleshooting table in the **SERVICE** section of this manual can help.

The test run consists of verifying the following:

- 1) The motor powers up and runs correctly.

**⚠ATTENTION**

Serious injury or death can result from using tool **BEFORE** understanding its controls and related safety information. **DO NOT** operate, or allow others to operate, tool until information is understood.

**⚠ATTENTION**

**DO NOT** start tool until all preceding setup instructions have been performed. Operating an improperly set up tool may result in malfunction or unexpected results that can lead to serious injury, death, or tool/ property damage.

**TO TEST RUN TOOL**

1. Clear away all setup/adjustment tools.
2. Verify blade is properly installed (see Changing Blade on Page 17).
3. Connect tool to power supply.
4. While firmly holding auxiliary handle (see Figure 8) in one hand, squeeze ON/OFF switch with opposite hand. Motor should run smoothly and without unusual problems or noises.
5. Release ON/OFF switch. Motor should immediately stop running.

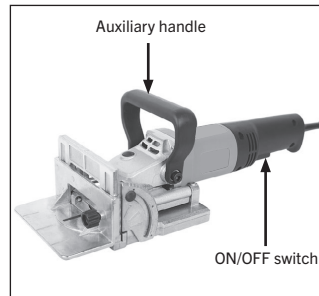

Fig. 8: Location of auxiliary handle and ON/OFF switch

## OPERATION

### ⚠ATTENTION

To reduce risk of eye injury from flying chips or lung damage from breathing dust, always wear safety glasses and a respirator when operating this tool.

### ⚠ATTENTION

If you are not experienced with this type of tool, we strongly recommend that you seek additional training outside of this manual. Read books/magazines or get formal training before beginning any projects. Regardless of the content in this section, Benchmark tool will not be held liable for accidents caused by lack of training.

### TURNING TOOL ON/OFF

- To start the tool squeeze the On/Off Trigger Switch
- Release the On/Off Trigger Switch to turn off

### ADJUSTING DEPTH OF CUT

The biscuit joiner can be adjusted to cut slots for standard #0, #10 and #20 biscuits, simplex fittings, and duplex hinges. Refer to the table in Figure 9 to determine biscuit size and cutting depth.

Biscuit #	Material Thickness (mm)	Cut Depth (mm)	Depth Indicator Marking
#10	4	8	0
#10	4	10	10
#20	4	12.5	20
Simplex	4	13	S
Dimplex	4	15	D
N/A	N/A	18	Max

Fig 9. Biscuit cut depth and depth scale marking table

### SETTING CUTTING DEPTH

1. Rotate depth indicator (see Figure 10) until desired depth marking on indicator aligns with arrow mark.

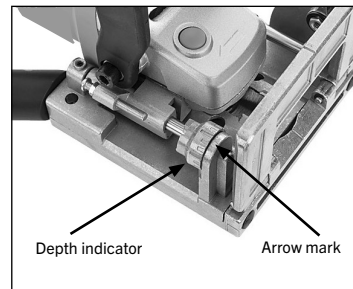

Fig 10. Depth indicator aligned with arrow mark

### ADJUSTING CUTTING DEPTH

1. DISCONNECT TOOL FROM POWER!
2. Rotate depth indicator until position "10" is aligned with arrow mark.
3. Push forward on auxiliary handle until depth stop contacts depth indicator and measure length of exposed blade from blade tooth tip to sliding base.
 

**Note:** Rotate saw blade until blade tooth tip is centered at the maximum distance from the sliding base.
4. Verify depth measurement as follows:
  - If measurement equals 10mm, the cutting depth is properly calibrated.
  - If measurement does not equal 10mm, loosen depth stop lock nut (see Figure 11).

#### **⚠ WARNING:**

Failure to correctly adjust the cutting depth could cause damage to the workpiece.

**Note:** Always make a trial cut on scrap material to confirm the settings and reduce or extend depth stop until measurement equals 10mm. Tighten depth stop lock nut once depth is reached.

### ADJUSTING CUTTING ANGLE

The faceplate can be adjusted between 0° and 90°, though 90° is the most common angle of cut for biscuit joining. Certain applications, such as joining beveled edges, require the biscuit to be inserted at different angles.

**Note:** Ball and groove detents on the angle scale are provided to set the angle at 0°, 45°, and 90°.

To adjust cutting angle:

1. Release angle lock (see Figure 12).
2. Tilt faceplate until desired angle on scale lines up with arrow mark.
3. Tighten angle lock.

### ADJUSTING CUTTING HEIGHT

The fence can be adjusted to a height of 0-40mm. Cutting height depends on your workpiece thickness. Set the cutting height to half the thickness of your workpiece for the strongest joint. To adjust cutting height:

1. Set faceplate angle to 90° (see Adjusting Cutting Angle above).

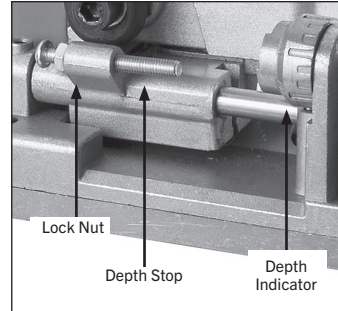

Fig 11. Location of cutting depth adjustment components.

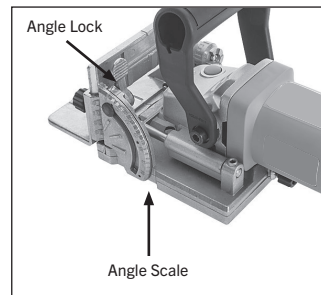

Fig 12. Location of cutting angle adjustment components.

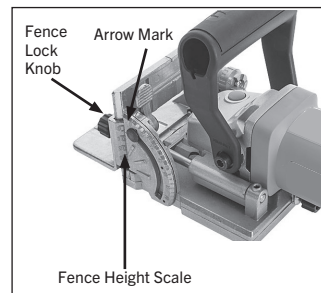

Fig 13. Location of cutting height adjustment components.

2. Loosen fence lock knob and move fence up or down on faceplate until arrow mark on angle scale aligns with desired height on fence height scale (see Figure 13).
3. Tighten fence lock knob once desired height is reached.

## WORKPIECE PREPARATION

Properly mark your workpieces to avoid incorrect biscuit placement and wasted material.

The following example illustrates a typical biscuit joining layout.

### LAYING OUT CUTS

1. Place edges of (2) workpieces flush against each other on a smooth, flat surface. Verify board ends line up.
2. Place marks  $2\frac{1}{2}$ " - 3" from each end of one board. **Note:** If distance between marks is greater than 6", place additional marks at 4"-6" intervals (see Figure 14).
3. Use a square to draw layout lines across boards through marks, then make registration marks on edge of each board to ensure correct edge is cut (see Figure 15).

### SECURING WORKPIECE

Your workpiece must be properly secured before making cuts. Cutting biscuit grooves with a biscuit joiner places pressure on the edge of the workpiece, which can cause an improperly secured workpiece to shift on the workbench, resulting in personal injury or damage to the tool or workpiece.

Use clamps to secure workpiece on workbench. Edge of workpiece should hang slightly over edge of workbench (see Figure 16).

**Note:** Clamps should be placed at least 3" from any cut marks to prevent interference with joiner.

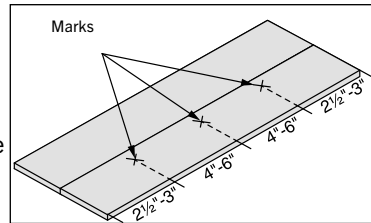

Fig 14. Biscuit location marks

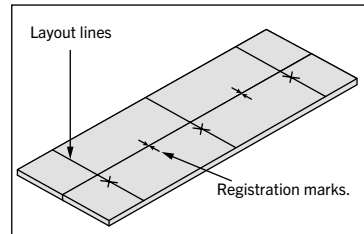

Fig 15. Layout lines and registration marks.

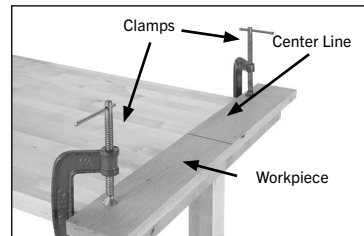

Fig 16. Example of workpiece setup.



### TO CUT BISCUIT GROOVES

1. Place fence on workpiece so front groove and rear groove line up with layout line, as shown in Figure 17. Make sure faceplate contacts edge of workpiece.
2. Turn biscuit joiner ON and allow motor to reach full speed.
3. With both hands holding tool, slowly push blade into workpiece, as shown in Figure 18, making sure joiner grooves remain aligned with layout line on workpiece, as described in Step 1.
4. Once blade reaches full depth, slide joiner body backward, allowing blade to retract into base plate.
5. Turn joiner OFF and wait for motor to come to a complete stop before setting tool down.

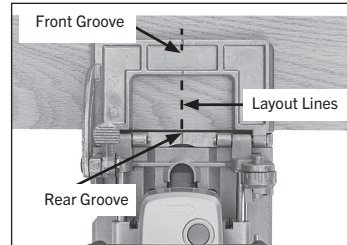

Fig 17. Biscuit joiner aligned with workpiece.

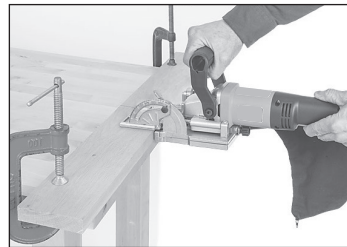

Fig 18. Biscuit joiner operation

### GLUING BISCUITS

Once all biscuit grooves have been cut, test-fit biscuits with a "dry fit" prior to the glue-up. Place a biscuit in each groove, and fit the pieces together to check for proper alignment.

Once a proper fit is verified, apply glue to workpiece edges and grooves, insert biscuits into grooves, then clamp according to the needs of the material and the glue manufacturer's instructions.

### CHANGING BLADE

This tool accepts 4" blades with either a 20mm or 22mm bore, depending on the position of the inner flange.

#### **⚠ ATTENTION**

To reduce risk of injury, always disconnect power from joiner before changing blades. Since blade is sharp, use extra care and wear gloves when installing it.

## TO CHANGE BLADE:

1. DISCONNECT TOOL FROM POWER!
2. Loosen fence lock knob and then slide fence up to remove it from faceplate (see Figure 19).
3. Turn tool over so bottom of sliding base is facing upward.
4. Loosen blade access knob (see Figure 20) until the sliding base lid can be raised.
5. Press spindle lock button (see Controls & Components on Page 10) and use spanner wrench to turn outer flange until spindle lock engages spindle (see Figure 21).
6. Continue to press spindle lock button, and use spanner wrench to loosen outer flange.
7. Remove blade and outer flange from spindle.

**Note:** If switching between blades with 20mm and 22mm bores, flip inner flange over before installing new blade to accommodate change in bore size (see Figure 22).

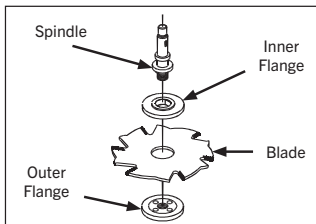

Fig. 22. Proper orientation of blade components for assembly.

8. Install new blade, verify teeth face correct direction for rotation of spindle, as shown in Figure 23
9. Place outer flange on spindle, press spindle lock button, and tighten outer flange with spanner wrench.
10. Close sliding base lid and tighten blade access knob.
11. Install fence to desired height, as shown in Adjusting Cutting Height on Page 13.

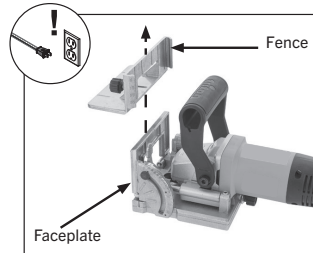

Fig. 19. Fence removed from faceplate

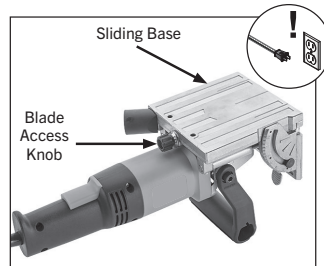

Fig. 20. Loosening blade access knob.

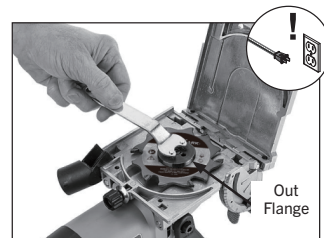

Fig. 21. Removing blade with spanner wrench

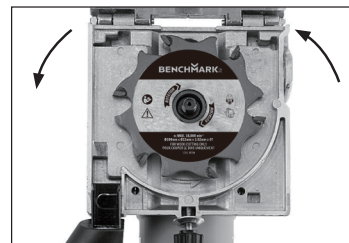

Fig. 23. Blade installed with teeth correct direction.

## MAINTENANCE

### ATTENTION

Always DISCONNECT POWER before servicing, adjusting, or doing maintenance to reduce risk of accidental injury or electrocution.

For optimum performance from this tool, routinely check the condition of the following items and repair or replace as necessary.

- Loose bolts
- Damaged bits
- Worn or damaged wires
- Any other unsafe condition

### CLEANING

Use a brush and a shop vacuum to remove wood chips and other debris from the tool, particularly from around the blade slot on the sliding base. Never blow off the tool with compressed air, as this could force wood chips deeper into the motor vents. Use a clean cloth to wipe away any dust remaining after each operation.

**Note: DO NOT** use caustic cleaners on plastic parts. If dry cleaning is insufficient, a mild detergent on a damp cloth is recommended. Keep water away from tool at all times.

### LUBRICATION

Periodically lubricate all moving parts with a light machine oil as needed. Place a drop of oil on the guide rails on both sides of the sliding base (see Figure 27), then slide the base back and forth, working the oil across the rails. Use a clean rag to wipe off any excess oil, which can collect sawdust or stain the workpiece.

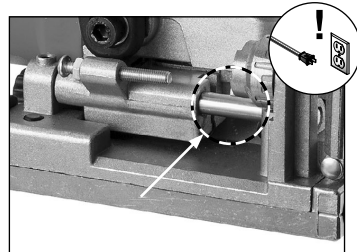

Fig. 27. Location of sliding base guide rail (1 of 2).

### REPLACING BRUSHES

This tool is equipped with a universal motor that uses two carbon brushes to transmit electrical current inside the motor. These brushes are considered to be regular "wear items" or "consumables" that will need to be replaced during the life of the motor. The frequency of required replacement is related to how much the motor is used and how hard it is pushed. Replace both carbon brushes at the same time when the motor no longer reaches full power, or when the brushes measure less than 1/4" long (new brushes are 5/8" long).

## TO REPLACE MOTOR BRUSHES:

1. DISCONNECT TOOL FROM POWER!
2. Remove (4) tap screws from left side of main joiner handle (see Figure 28), and separate both sides of handle.  
**Note:** Make sure not to pull on or damage the wires located in main handle during disassembly.
3. Locate and remove (2) motor brushes (see Figure 29).  
**Note:** If removing the brushes by hand is too difficult, carefully use a small screwdriver to push down on the brush holder tabs to release them.
4. Replace motor brushes and install main handle

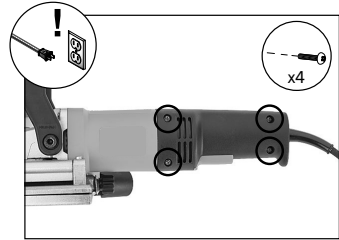

Fig. 28. Location of main handle fasteners

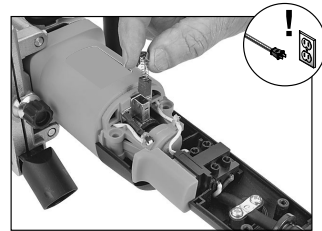
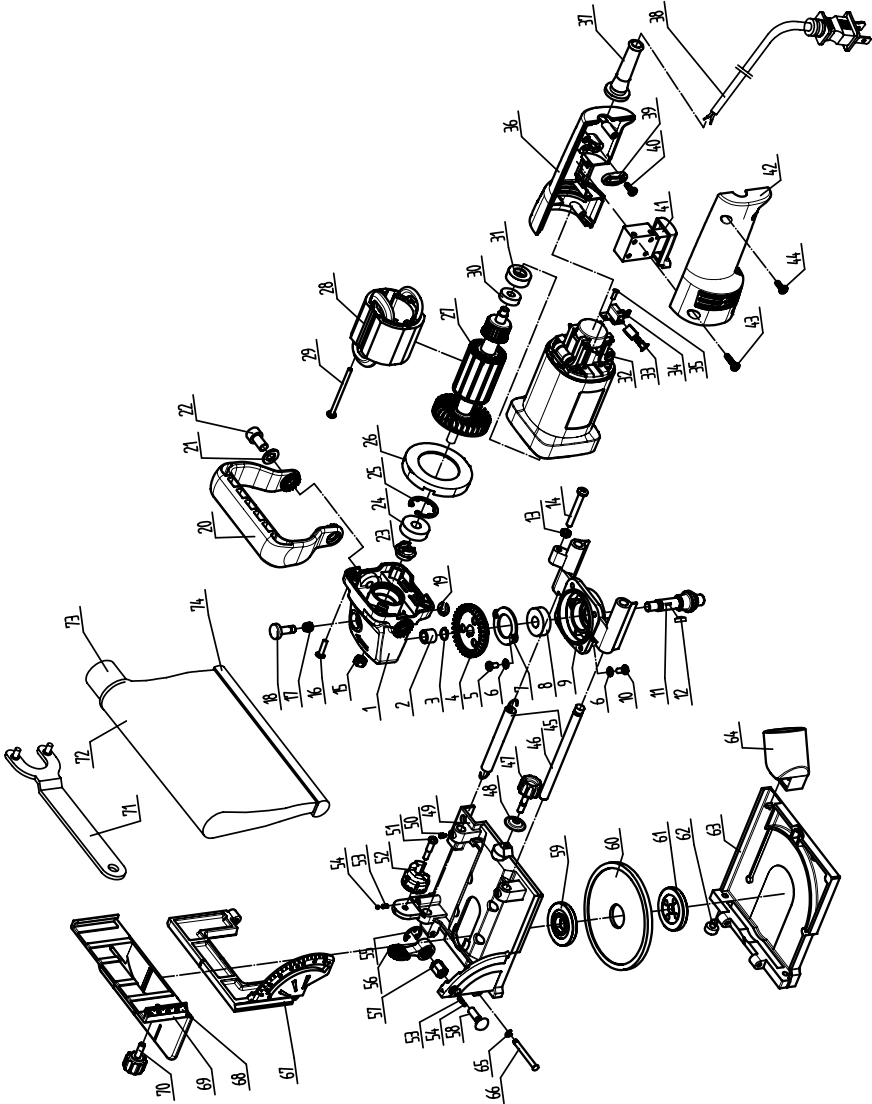

Fig. 29. Replacing motor brush (1 of 2)

**TROUBLESHOOTING**

<b>Symptom</b>	<b>Possible Cause</b>	<b>Possible Solution</b>
Tool does not start, or power-supply fuse/breaker trips after startup.	<ol style="list-style-type: none"> <li>1. Power supply circuit breaker tripped or fuse blown.</li> <li>2. Incorrect power supply voltage or circuit size.</li> <li>3. Wiring broken, disconnected, or corroded.</li> <li>4. Motor brushes at fault.</li> <li>5. ON/OFF switch at fault.</li> <li>6. Motor at fault.</li> </ol>	<ol style="list-style-type: none"> <li>1. Ensure circuit is sized correctly/free of shorts. Reset circuit breaker/replace fuse.</li> <li>2. Ensure correct power supply voltage and circuit size.</li> <li>3. Check/fix broken, disconnected or corroded wires.</li> <li>4. Remove/replace (Page 17).</li> <li>5. Replace switch.</li> <li>6. Test/repair/replace.</li> </ol>
Tool stalls or is underpowered.	<ol style="list-style-type: none"> <li>1. Workpiece material not suitable for tool.</li> <li>2. Tool undersized for task.</li> <li>3. Dust bag at fault.</li> <li>4. Blade at fault.</li> <li>5. Motor brushes at fault.</li> <li>6. Motor bearings at fault.</li> <li>7. Motor overheated.</li> <li>8. Motor at fault.</li> </ol>	<ol style="list-style-type: none"> <li>1. Only cut wood/ensure moisture is below 20%.</li> <li>2. Reduce feed rate/depth of cut.</li> <li>3. Empty bag/clear dust port.</li> <li>4. Remove/replace (Page 15).</li> <li>5. Remove/replace (Page 17).</li> <li>6. Test/repair/replace.</li> <li>7. Clean motor, let cool, and reduce workload.</li> <li>8. Test/repair/replace.</li> </ol>
Tool has vibration or noisy operation.	<ol style="list-style-type: none"> <li>1. Motor, blade, or component loose.</li> <li>2. Blade at fault.</li> <li>3. Workpiece loose.</li> <li>4. Motor bearings at fault.</li> </ol>	<ol style="list-style-type: none"> <li>1. Tighten if loose. Replace damaged or missing bolts/nuts.</li> <li>2. Remove/replace (Page 15).</li> <li>3. Use the correct holding fixture/reclamp workpiece.</li> <li>4. Test by rotating shaft; rotational grinding/looseshaft requires bearing replacement.</li> </ol>
Blade is burning workpiece.	<ol style="list-style-type: none"> <li>1. Blade at fault.</li> </ol>	<ol style="list-style-type: none"> <li>1. Remove/replace (Page 15).</li> </ol>

## EXPLODED VIEW



**PARTS LIST**** WARNING:**

When servicing, use only original equipment replacement parts. The use of any other parts may create a safety hazard or cause damage to the biscuit joiner.

Any attempt to repair or replace electrical parts on this power washer may create a safety hazard unless repairs are performed by a qualified technician.

For more information, call the Toll-free Helpline, at 1-866-349-8665;  
Monday - Friday: 9am to 5pm Eastern Standard Time.

Always order by key number.

Key#	Part #	Part Name	Qty
1	1261-000-001	GEAR BOX	1
2	1261-000-002	OIL BEARING	1
3	1261-000-003	RETAINING RING	1
4	1261-000-004	LARGE GEAR	1
5	1261-000-005	SCREW	2
6	1261-000-006	SPRING WASHER	6
7	1261-000-007	BEARING CAP	1
8	1261-000-008	BEARING	1
9	1261-000-009	FRONT CAP	1
10	1261-000-010	SCREW	4
11	1261-000-011	OUTPUT SHAFT	1
12	1261-000-012	WOODRUFF KEY	1
13	1261-000-013	HEX BOLT	1
14	1261-000-014	SCREW	1
15	1261-000-015	NUT	1
16	1261-000-016	SCREW	4
17	1261-000-017	SPRING	1
18	1261-000-018	LOCK	1
19	1261-000-019	SPLIT RING	1
20	1261-000-020	HANDLE	1
21	1261-000-021	HANDLE WASHER	2
22	1261-000-022	SCREW	2
23	1261-000-023	PINION GEAR	1
24	1261-000-024	BEARING	1
25	1261-000-025	RETAINING RING	1
26	1261-000-026	WIND BAFFLE	1
27	1261-000-027	ARMATURE	1

Key#	Part #	Part Name	Qty
28	1261-000-028	STATOR	1
29	1261-000-029	SCREW	2
30	1261-000-030	BEARING	1
31	1261-000-031	BEARING CAP	1
32	1261-000-032	HOUSING	1
33	1261-000-033	BRUSH	2
34	1261-000-034	BRUSH HOLDER	2
35	1261-000-035	RIVET	4
36	1261-000-036	RIGHT HANDLE	1
37	1261-000-037	CABLE COVER	1
38	1261-000-038	CABLE	1
39	1261-000-039	CABLE CLAMP	1
40	1261-000-040	SCREW	2
41	1261-000-041	SWITCH	1
42	1261-000-042	LEFT HANDLE	1
43	1261-000-043	SCREW	2
44	1261-000-044	SCREW	2
45	1261-000-045	SPRING	2
46	1261-000-046	GUIDE	2
47	1261-000-047	COVER BOWL SCREW	1
48	1261-000-048	COVER BOWL	1
49	1261-000-049	UPPER BASE	1
50	1261-000-050	SCREW	2
51	1261-000-051	SCREW	1
52	1261-000-052	STOP BLOCK	1
53	1261-000-053	SPRING	2
54	1261-000-054	STEEL BALL	2
55	1261-000-055	CHECK RING	1
56	1261-000-056	LOCK BUTTON	1
57	1261-000-057	NUT	1
58	1261-000-058	BOLT	1
59	1261-000-059	BLADE FLANGE	1
60	1261-000-060	BLADE	1
61	1261-000-061	BLADE FLANGE	1
62	1261-000-062	RUBBER	2
63	1261-000-063	LOWER BASE	1



Key#	Part #	Part Name	Qty
64	1261-000-064	DUST BENDING TUBE	1
65	1261-000-065	SPLIT RING	2
66	1261-000-066	BASE PIN	2
67	1261-000-067	ANGLE PLATE	1
68	1261-000-068	HEIGHT RULER	1
69	1261-000-069	HEIGHT PLATE	1
70	1261-000-070	SCREW	1
71	1261-000-071	WRENCH	1
72	1261-000-072	DUST BAG	1
73	1261-000-073	SEALING STRIP	1
74	1261-000-074	DUST COLLECTION TUBE	1

## **WARRANTY**

### **BENCHMARK BISCUIT JOINER**

If this Benchmark tool fails due to a defect in material or workmanship within five years from the date of purchase, return it to any Home Hardware store with the original bill of sale for exchange. 3-year warranty for the battery and charger. This warranty does not include expendable parts including but not limited to blades, brushes, belts, light bulbs.

This warranty covers defects in material or workmanship only. It does not cover normal wear and tear, failure due to abuse/misuse, or defects caused by careless or accidental mishandling. If this Benchmark product is used for commercial or rental purposes, this warranty does not apply.





# BISCUIT JOINER



5 year limited warranty on tool

**BENCHMARK™**  
MC

**BENCHMARK TOOLS CANADA**

ST. JACOBS, ONTARIO N0B 2N0

© 2021 Home Hardware Stores Limited

**CUSTOMER SERVICE/TECH SUPPORT**

1-866-349-8665

**1261-000**

Made in China



\* This Benchmark™ product carries a five (5) year LIMITED warranty against defects in workmanship and materials. The charger and batteries carry a three (3) year LIMITED warranty. See Owner's Manual for full details.



**READ ALL INSTRUCTIONS BEFORE FIRST USE.  
KEEP THIS MANUAL FOR FUTURE REFERENCE.  
KEEP AWAY FROM CHILDREN.**



**WEAR CSA APPROVED  
EYE PROTECTION**



**WEAR EAR  
PROTECTION**



**WEAR A  
FACE MASK**